

SYNERGY

High efficiency combi boiler

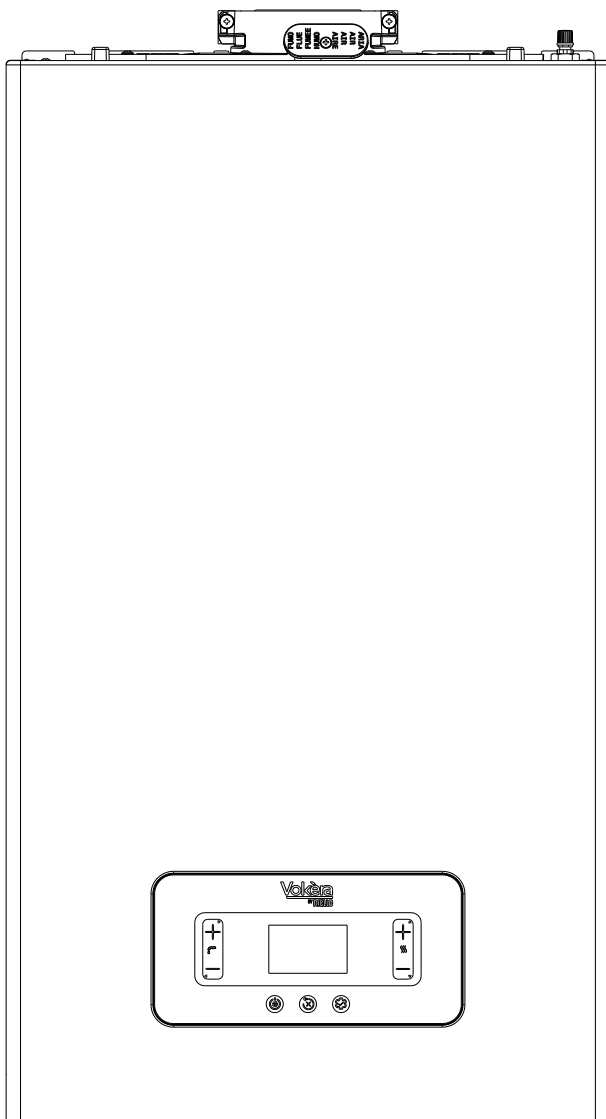

Users Instructions

Installation & Servicing Instructions



SYNERGY 25C NG G.C. N° 47-364-76

SYNERGY 30C NG G.C. N° 47-364-77

SYNERGY 35C NG G.C. N° 47-364-78

THESE INSTRUCTIONS
TO BE RETAINED
BY USER



Vokèra is a licensed member of the Benchmark scheme which aims to improve the standards of installation and commissioning of domestic hot water systems in the UK.

1. THINGS YOU SHOULD KNOW.....	2	SECTION 5 - COMMISSIONING	21
2. GETTING STARTED.....	3	SECTION 6 - MAINTENANCE AND CLEANING	27
3. CONTROL PANEL.....	3	SECTION 7 - CONTROL PANEL.....	34
4. HOW TO.....	6	SECTION 8 - DETAILED INSTRUCTIONS FOR USE.....	35
5. WHAT IF.....	6	SECTION 9 - SERVICING INSTRUCTIONS.....	38
SECTION 1 - DESIGN PRINCIPLES AND OPERATING SEQUENCE	8	SECTION 10 - CHECKS, ADJUSTMENTS AND FAULT FINDING ..	39
SECTION 2 - TECHNICAL DATA	9	SECTION 11 - LPG INSTRUCTIONS	42
SECTION 3 - GENERAL REQUIREMENTS (UK)	12	Commissioning checklist	43
SECTION 3A - GENERAL REQUIREMENTS (EIRE).....	14	Benchmark.....	44-47
SECTION 4 - INSTALLATION	15		

USERS INSTRUCTIONS

INTRODUCTION

Dear Customer

Your Vokera **SYNERGY** boiler has been designed to meet and exceed the very latest standards in gas central heating technology, and if cared for, will give years of reliable use and efficiency. Please therefore take some time to read these instructions carefully.

Do's and Don't's

- **Do** ensure that the system pressure is periodically checked
- **Do** ensure that the boiler should not be used by children or unassisted disabled people
- Do ensure that you know how to isolate the appliance in an emergency
- **Do** ensure that you are familiar with the appliance controls
- **Do** ensure that your installer has completed the appliance log book section
- **Do not** attempt to remove the appliance casing or gain internal access
- **Do not** hang clothes etc. over the appliance
- **Do not** forget to have the appliance serviced annually.

This booklet is an integral part of the appliance. It is therefore necessary to ensure that the booklet is handed to the person responsible for the property in which the appliance is located/installed. A replacement copy can be obtained from the Vokera website

For the warranty terms and conditions please refer to www.vokera.co.uk (UK) or www.vokera.ie (ROI).



At the end of its life, the product should be not be disposed of as solid urban waste, but rather it should be handed over to a differentiated waste collection centre.

1. THINGS YOU SHOULD KNOW

1.1 GAS APPLIANCES

Gas Safety (Installation and Use) Regulation (UK).

In the interests of your safety and that of others it is a legal requirement that all gas appliances are installed and correctly maintained by a competent person and in accordance with the latest regulations.

1.2 ELECTRICAL SUPPLY

Please ensure that this appliance has been properly connected to the electrical supply by means of a double pole isolator, and that the correct size of fuse (3 AMP) has been fitted.

Warning: this appliance must be earthed!

1.3 WARRANTY REGISTRATION

Please take the time to register the appliance warranty which can be done via the Vokera websites - Vokera.co.uk (UK) & Vokera.ie (Ireland) (please have your appliance warranty card to hand).

1.4 APPLIANCE COMMISSIONING CHECKLIST (UK only)

The Benchmark checklist section can be found at the rear of the appliance installation booklet. This important document must be completed during the installation/commissioning of your boiler. All GAS SAFE registered installers carry a GAS SAFE ID card, and have a registration number. These details should be recorded in the Benchmark commissioning checklist section within the installation booklet. You can check your installers details by calling GAS SAFE direct on 08004085500. Failure to install and commission the appliance in accordance with the manufacturers instructions will invalidate the warranty. This does not affect your statutory rights.

1.5 HOW DOES IT WORK?

Your **SYNERGY** boiler supplies heated water to your radiators and hot water to your hot water taps. The central heating is controlled via a time clock and any thermostats that your installer may have fitted. The boiler will light when it receives a request from the time clock via any thermostat that may be installed, or whenever a hot water outlet (tap) is opened. Your **SYNERGY** boiler lights electronically and does not have a pilot light. In the unlikely event of a fault developing with your boiler, the supply of gas to the burner will be terminated automatically.

1.6 DIMENSIONS

	HEIGHT	WIDTH	DEPTH
25C-30C-35C	740 mm	420 mm	275 mm

1.7 CLEARANCES REQUIRED

ABOVE	25mm*
BELOW	200mm [^]
LEFT SIDE	5mm
RIGHT SIDE	5mm**
FRONT	4mm***

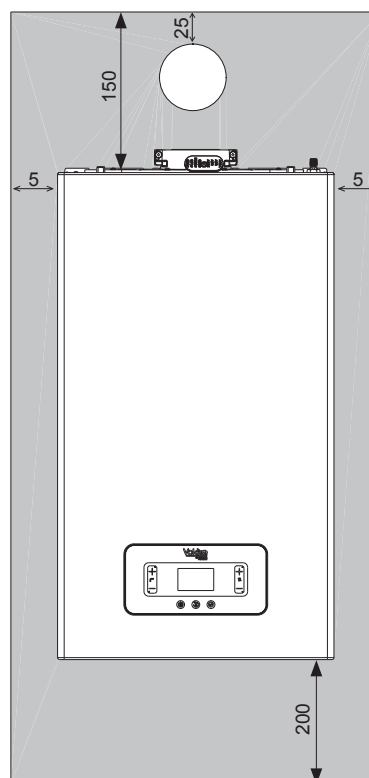

* 25mm above flue bend if top flue outlet is used. Consideration should be given to providing reasonable clearance for the insertion of a FGA probe.

** Disconnection of adjacent components may be required in order to facilitate syphon removal.

*** Provided that a door or removal panel enables 420mm access for maintenance.

[^] Can be reduced to 5mm if a removal panel enables 200mm for maintenance.

2. GETTING STARTED

2.1 BEFORE SWITCHING ON

Before switching the appliance on, please familiarise yourself with:

- how to isolate the appliance from the gas, water, and electricity supplies;
- how to check and top-up – if necessary – the system water pressure;
- any external thermostats and their functions;
- the appliance controls.

2.2 APPLIANCE CONTROLS (see page 2)

NOTE: the appliance frost protection is active in all the boiler modes.

The **control panel functions** can be used to vary the temperature of the water that circulates around your radiators and the water that flows from your hot water taps. The heating temperature range can be adjusted between 20C - 40C (low temperature) or 40C - 80C (high temperature) this range is configured by your installer and the default is the high temperature range. The hot water temperature range can be adjusted between 37C - 60C. **Please Note:** the actual delivery temperature is also conditional upon the incoming water temperature and the actual flow-rate at the outlet.

Refer to the main appliance status table for fault indicator and boiler status.

2.3 LIGHTING THE BOILER

Ensure the gas and electrical supply to the boiler are turned on. After completing all operations required to prepare commissioning, proceed as follows to start the boiler.

2.4 START SCREEN

When the appliance is first connected to the electrical supply, the UI may require you to set the time and date (see section 8), and the appliance will enter its 'pre-purge' mode that will last for several minutes. On completion of the 'pre-purge' phase, the appliance will enter its 'standby' mode unless a heating or HW request has been made. By pressing button '1' it is possible to move to the desired selection (OFF, SUMMER, WINTER).





2.5 HOW TO RESET THE APPLIANCE



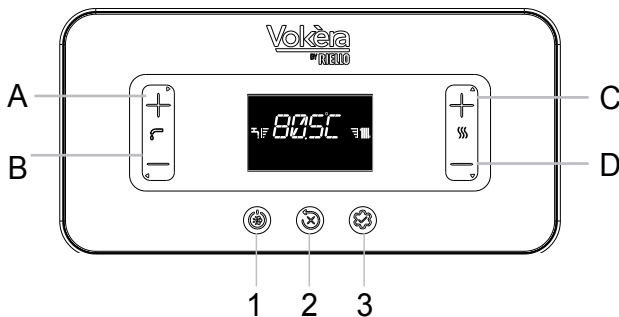

















Reset function

In order to reset the boiler's operation in the event of a fault, refer to the adjacent pages for information on the meaning of the various alarm or fault codes; and how to carry out a reset.

3. CONTROL PANEL



A	Normally used to increase the domestic hot water temperature value, when the arrow is highlighted  it carries out a confirmation function
B	Normally used to decrease the DHW temperature value, but when the arrow  is highlighted it acts as a back/annul button
A+B	Access to the DHW comfort functions (see section 5.11)
C+D	Heating time programming, status change
C	Normally used to increase the heating water temperature value, when highlighted the arrow  allows you to move within the menu P1
D	Normally used to decrease the heating water temperature value, when highlighted the arrow allows  you to move within the menu P1
A+C	Access to the clock setting menu (see section 8)
B+D	Time band programming
1	Used to modify the boiler operating status (OFF, SUMMER and WINTER)
2	Used to reset the alarm status, or to interrupt the venting cycle
3	Used to access menus INFO (press lightly) and P1 (press > 2 sec). When the  icon appears on the display, this button has an ENTER function and is used to confirm the value set while programming a technical parameter
1+3	Button lock and release
2+3	Used when the boiler is OFF, to activate the flue gas analysis function (CO)



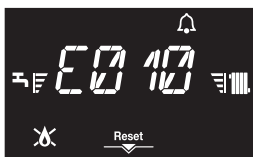

	Indicates connection to a remote device (OTBus or RS485)
	Indicates connection to a WIFI device
	Indicates the presence of an outdoor temperature sensor
	Indicates the activation of special DHW functions, or the presence of a solar thermal management system
	Lights up if an alarm is triggered
	Lights up in the event of a fault together with the icon  , excluding flame and water alarms
	Indicates presence of a flame, in the event of a flame lockout the icon appears 
	Flashes with temporary water alarms, steady with definitive alarms
	Lights up in the presence of alarms requiring manual release by the operator
	Lights up when confirmation is required
	When this icon is active, the "confirm" function of button A is active
	When this icon is active, the "back/annul" function of button B is active
	When this icon is active, the user can navigate the menu or increase the value of the selected parameter
	When this icon is active, the user can navigate the menu or decrease the value of the selected parameter
	Lights up if heating mode is active; flashes with a heating request in progress
	Lights up if DHW mode is active; flashes with a DHW request in progress
	Indicate the set point level (1 notch minimum value, 4 notches maximum value)
1 2 3 4 5 6 7	Indicate the days of the week
AUTO ON 	Time band programming
MAN ON	Manual time programming ON
MAN OFF	Manual time programming OFF

3.1 Signalling and faults

If a fault is present, the icon  blinks at a frequency of 0.5sec ON and 0.5sec OFF, the backlight blinks for 1min at a frequency of 1sec ON and 1sec OFF, after which it switches off, while the bell continues to flash. The error code appears on the 4 digits of the display.



When a fault occurs, the following icons may appear:

-  lights up for a flame alarm (E010)
- RESET lights up for an alarm that needs to be manually reset by the user (e.g. a flame lockout)
-  lights up along with the , apart from flame lockout and water failure faults
-  lights up in the presence of water pressure alarms or warnings, in which case the water pressure value is displayed as an alternative to the fault code every 3 seconds.

Reset function

To restore boiler operation in the event of a fault, the boiler must be operated by pressing the RESET button.

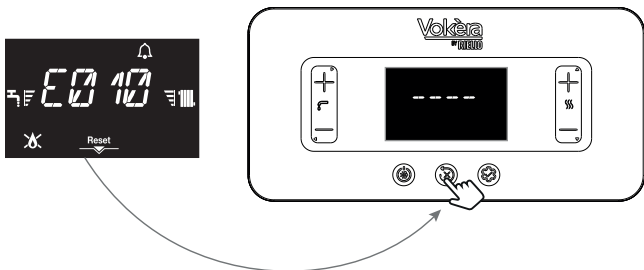

At this point, if the correct operating conditions have been restored, the boiler will restart automatically. Up to a maximum of 5 consecutive attempts to unlock the same alarm from the interface are possible, after which the error code E099 appears on the display.

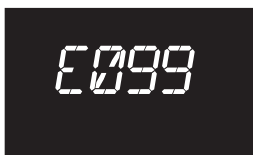

In this case, the boiler must be disconnected from the electricity supply and then reconnected again, to reactivate operation.

 If the reset attempts do not activate the boiler, contact the Technical Assistance Centre.

Fault E041

Should the pressure value fall below the safety value of 0.3 bar, the boiler displays the fault code E041 for a transitory time of 10 min.

When the transitional time has finished, if the fault persists the fault code E040 is displayed.

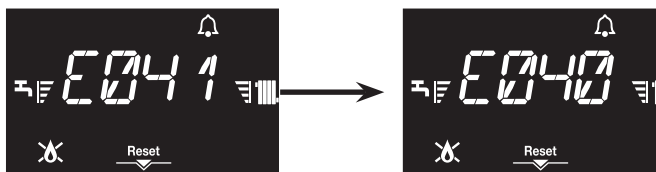

With a boiler in fault E040:

- attach the temporary flexi-pipe and open both filling taps A&B
- check that the pressure value reaches 1-1.5 bar by means of a hydrometer located under the shelf or by accessing the INFO menu (section 6.4, item I018)
- close both A&B taps and remove the flexi-pipe.

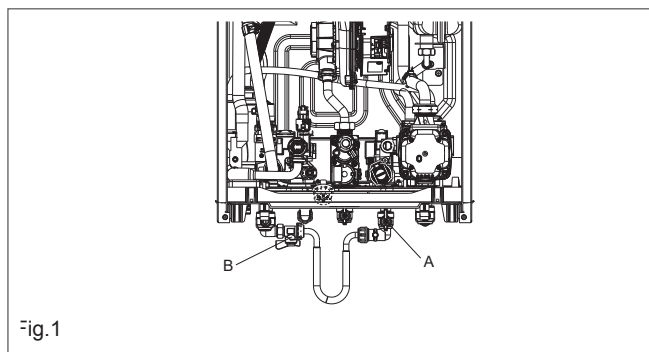



Fig.1

Press  to restore operation.

Once operation is restored, the boiler performs an automatic vent cycle as described in section 5.8.

 If the drop in pressure is quite frequent, contact your installer and ask him to check your system.

Fault E060

The boiler is working normally, but does not guarantee the stability of the DHW temperature that is, however, supplied at a temperature of around 50°C. Intervention of the Technical Assistance Centre is required.

Fault E091

The boiler has an auto-diagnostic system which, based on the total number of hours in certain operating conditions, can signal the need to clean the primary exchanger (alarm code E091).

Once the cleaning operation has been completed, reset to zero the total hour meter with special kit supplied as an accessory following procedure indicated below:

- access the technical parameters → P3 → P312 → P312 = 1 → confirm.

NOTE: The meter resetting procedure should be carried out after each in-depth cleaning of the primary heat exchanger or if it is replaced.

The fault E091 occurs when the hour counter exceeds 2500 hours; this value can be verified as follows:

- access the INFO menu → I015 to display the value of the flue gas probe hour counter (display/100, example 2500h = 25).

ERROR CODE	ERROR MESSAGE	ALARM DESCRIPTION	
E010	Flame lockout	DEFINITIVE	
E011	Parasitic flame		
E012	Maximum number of flame losses		
E013	Hardware test failed		
E014	Flame detect test failed		
E015	Voltage detect flame test failed		
E020	Limit thermostat		
E021	Gas valve control malfunctioning		
E030	Fan error		
E031	Fan failure mechanical blockage		
E032	Rotor fan failure blocked		
E033	Rotor fan failure damaged		
E034	Chimney obstruction in preventilation		
E035	Blockage obstruction flue gas low power		
E036	Blockage obstruction flue gas high power		
E037	Failed combustion check low power		
E038	Combustion check failed check high power		
E039	Abnormal flame value		
E040 + bar value	Water pressure low... Fill the system		
E042	Water transducer - LWCO error		
E075	Valve opening limit reached		
E092	Calibration FAILED		
E088	CAC failed		
E093	Too many calibration attempts		
E094	Lambda over limit		
E097	Check failed		
E098	GAC failed		
E099	Reset attempts exhausted		
E041 + bar value	Fill the system		TRANSITORY
E050	Smoke obstruction error low power		
E051	Smoke obstruction error high power		
E052	Hardware error out of threshold		
E055	No card fan communication		
E056	No communication microprocessor card		
E060	DHW probe error		
E070	CH probe error		
E071	CH probe overtemp		
E072	Return - Flow differential		
E077	Water thermostat main zone		
E080	Return probe error		
E081	Return probe overtemp		
E082	Flow - Return differential		
E090	Exhaust probe error		
E091	Clean primary ht exchanger		
E095	Calibration failed		
E096	Lambda over limit		
FIL + bar value	Low pressure check the htg system		
 flashing + bar value	High pressure check the htg system	SIGNAL	
COM	Appliance PCB communication lost (more than 30 seconds)	SIGNAL: (the boiler continues to operate but with no display or keys)	
E065	IMOD error	SIGNAL	
FWER	Warning firmware versions not compatible	SIGNAL: (the boiler continues to operate but with no display or keys)	
CFS	Call for Service	SIGNAL	
SFS	Stop for Service	DEFINITIVE	
OBCD	On board clock damaged	SIGNAL: (the boiler continues to operate but with no display or keys)	

4. HOW TO...

4.1 HOW TO TOP-UP THE SYSTEM PRESSURE

The system pressure must be checked periodically to ensure the correct operation of the boiler. The system pressure is shown at the top of the LCD display or can be read on the gauge located on the underside of the appliance. When the boiler is at room temperature, the system pressure should be approximately 1.0 bar. If the pressure requires 'topping-up' use the following instructions as a guide.

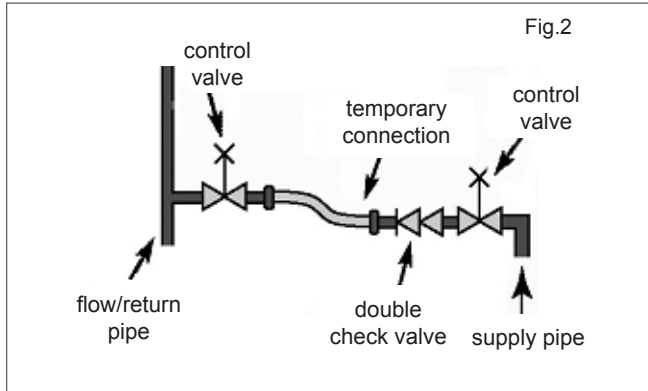

- Locate the filling valve connections (usually beneath the boiler, see fig. 2).
- Attach the filling loop to both connections.
- Open the filling valve slowly until you hear water entering the system.
- Close the filling valve when the pressure gauge (on the boiler) reads between 1 and 1.5 BAR.
- Remove the filling loop from the connections.

4.2 HOW TO CARE FOR THE APPLIANCE

To clean the outer casing use only a clean damp cloth. Do not use any scourers or abrasive cleaners.

5. WHAT IF...

5.1 WHAT IF I SUSPECT A GAS LEAK

If you suspect a gas leak, turn off the gas supply at the gas meter and contact your installer or local gas supplier. If you require further advice please contact your nearest Vokèra office.

5.2 WHAT IF I HAVE FREQUENTLY TO TOP-UP THE SYSTEM

If the system regularly requires topping-up, it may be indicative of a leak. Please contact your installer and ask him to inspect the system.

5.3 WHAT IF THE APPLIANCE IS DUE ITS ANNUAL SERVICE

Advice for tenants only

Your landlord should arrange for servicing.

Advice for homeowners

Please contact Vokèra Customer Service (**0330 236 8630 (UK)** or **056 7755055 (ROI)**) if you would prefer a Vokèra service engineer or agent to service your appliance. Alternatively your local GAS SAFE registered engineer may be able to service the appliance for you.

5.4 WHAT IF I NEED TO CALL AN ENGINEER

If you think your boiler may have developed a fault, please contact your installer or Vokèra Customer Services (**0330 236 8630 (UK)** or **056 7755055 (ROI)**) have all your details to hand including full address and postcode, relevant contact numbers, and your appliance log book. It is a requirement of your warranty terms & conditions that your Benchmark logbook has been filled out correctly and is fully up to date.

INSTALLATION AND SERVICING INSTRUCTIONS

INTRODUCTION

All installers are asked to follow the Benchmark Scheme by adhering to the Code of Practise, details of which can be obtained from www.benchmark.org.uk.

The **SYNERGY** has a ACC (Active Combustion Control) system. This control system ensures functionality, efficiency and low emissions under any conditions.

The ACC system uses an ionisation sensor immersed in the burner flame, whose information allows the control board to operate the gas valve that regulates the fuel.

This sophisticated control system provides the auto-regulation of the combustion, so there is no need for an initial calibration. The ACC system is able to adapt the boiler to operate with different gas compositions, different outlet pipes lengths and different altitudes (within the specified design limits).

The ACC system can also perform an auto-diagnostic operation that locks out the burner before the permitted upper emission limit is exceeded.

The **SYNERGY** product family comprises a range of high-efficiency combination boilers. These appliances – by design – incorporate electronic ignition, circulating pump, expansion vessel, safety valve, pressure gauge and automatic by-pass.

The range is produced as room sealed, category II2H3P-II2HY203P appliances, suitable for internal wall mounting applications only. Each appliance is provided with a fan powered flue outlet with an annular co-axial combustion air intake that can be rotated – horizontally – through 360 degrees for various horizontal or vertical applications.

These appliances are designed for use with a sealed system only; consequently they are not intended for use on open vented systems.

The boiler is suitable for use with combustible gases group H and/or group E and natural gas mixtures and hydrogen up to 20% by volume.

This booklet is an integral part of the appliance. It is therefore necessary to ensure that the booklet is handed to the person responsible for the property in which the appliance is located/installed. A replacement copy can be downloaded from the Vokera website - www.vokera.co.uk.

The boiler complies with basic requirements of the following Directives:

- Regulation (EU) 2016/426;
- Yield directive: Article 7(2) and Annex III of directive 92/42/EEC;
- Electromagnetic compatibility directive 2014/30/EU;
- Low-voltage directive 2014/35/EU;
- Directive 2009/125/EC Ecodesign for energy-using appliances;
- Regulation (EU) 2017/1369 Energy labeling;
- Delegated Regulation (EU) No. 811/2013;
- Delegated Regulation (EU) No. 813/2013;
- Regulation UNI/TS 11854

⚠ Before connecting the “Hi, Comfort T300 or K100” devices, it is necessary to correctly set P801=2 (in the P8 CONNECTIVITY menu) to avoid communication error problems as indicated in paragraph 8.11.

♻ At the end of its life, the product should be not be disposed of as solid urban waste, but rather it should be handed over to a differentiated waste collection and/or recycling centre.

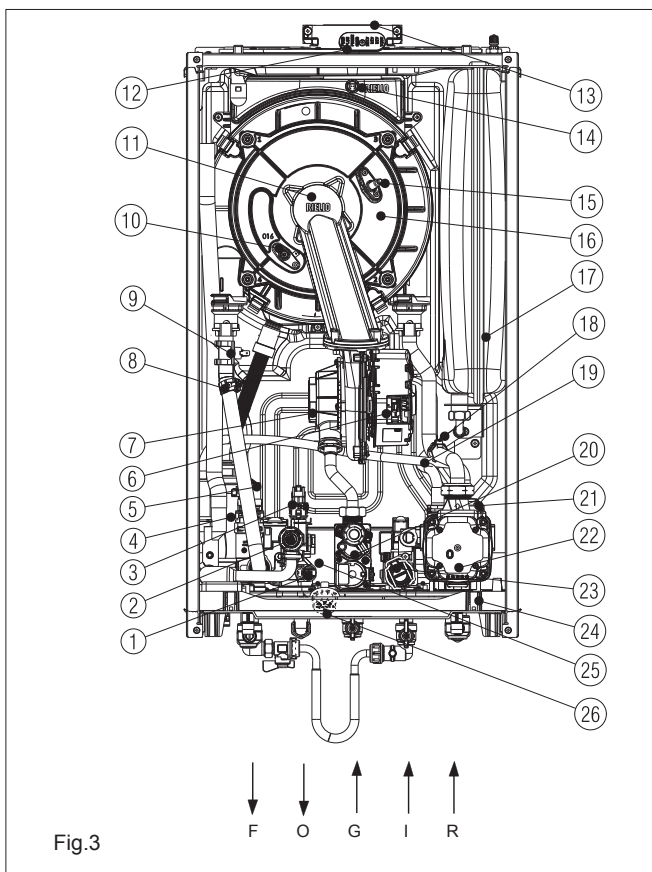

Fig.3

General layout

- 1 Domestic hot water NTC probe
 - 2 Safety valve
 - 3 Pressure transducer
 - 4 Siphon
 - 5 3-way valve
 - 6 Fan
 - 7 Mixer
 - 8 NTC delivery probe
 - 9 Limit thermostat
 - 10 Flame detection electrode/ionisation sensor
 - 11 Burner
 - 12 Combustion analysis socket plug
 - 13 Flue gas exhaust
 - 14 Flue gas probe
 - 15 Flame ignition electrode
 - 16 Exchanger
 - 17 Expansion vessel
 - 18 NTC return probe
 - 19 Degassing pipe
 - 20 Gas valve
 - 21 Air vent valve
 - 22 Circulator
 - 23 Flow meter
 - 24 Drain tap
 - 25 DHW exchanger
 - 26 Hydrometer
- R Heating return connection
 F Heating flow connection
 G Gas connection
 O Hot water outlet
 I Cold water inlet

1. SECTION - DESIGN PRINCIPLES AND OPERATING SEQUENCE

1.1 PRINCIPLE COMPONENTS

- A fully integrated electronic control board featuring electronic temperature control, anti-cycle control, pump over-run, self-diagnostic fault indicator, full air/gas modulation
- Stainless-steel heat exchanger
- Electronic ignition with flame supervision
- Integral high-head pump
- Fan
- Expansion vessel
- Water flowmeter
- Flue sensor
- Pressure transducer
- Safety valve

1.2 MODE OF OPERATION (AT REST)

When the appliance is at rest and there are no requests for heating or hot water, the following functions are active:

- frost-protection system: the frost-protection system protects the appliance against the risk of frost damage both for CH and DHW. For CH line, if the main temperature falls to 5°C, the appliance will function on minimum power until the temperature on main reaches 35°C. Moreover if the DHW temperature falls to 5°C, the appliance will function on minimum power until the temperature on main reaches 55°C.
- anti-block function: the anti-block function enables the pump and divertor valve actuator to be energised for short periods, when the appliance has been inactive for more than 24-hours.

1.3 MODE OF OPERATION (HEATING)

When there is a request for heat via the onboard clock and/or any external control, the pump and fan are started, the fan speed will modulate until the correct signal voltage is received at the control PCB. At this point an ignition sequence is enabled. Ignition is sensed by the electronic circuit to ensure flame stability at the burner. Once successful ignition has been achieved, the electronic circuitry increases the gas rate to 75% for a period of 15 minutes. Thereafter, the boiler's output will either be increase to maximum or modulate to suit the set requirement. When the appliance reaches the desired temperature the burner will shut down and the boiler will perform a three-minute anti-cycle (timer delay).

When the request for heat has been satisfied the appliance pump and fan may continue to operate to dissipate any residual heat within the appliance.

1.4 MODE OF OPERATION (HOT WATER)

When there is a request for DHW via a hot water outlet or tap, the pump and fan are started, the fan speed will modulate until the correct signal voltage is received at the control PCB. At this point an ignition sequence is enabled.

Ignition is sensed by the electronic circuit to ensure flame stability at the burner. Once successful ignition has been achieved, the electronic circuitry increases the gas rate to maximum or will modulate output to stabilise the temperature. In the event of the appliance exceeding the desired temperature (set point) the burner will shut down until the temperature drops. When the request for DHW has been satisfied the appliance pump and fan may continue to operate to dissipate any residual heat within the appliance.

1.5 SAFETY DEVICES

When the appliance is in use, safe operation is ensured by:

- a pressure transducer that monitors system water pressure and will de-activate the pump, fan, and burner should the system water pressure drop below the required minimum value;
- fan speed sensor to ensure safe operation of the burner;
- a high limit thermostat that over-rides the temperature control circuit to prevent or interrupt the operation of the burner;
- flame sensor that will shut down the burner when no flame signal is detected and/or when incomplete combustion or high emissions are detected;
- flue sensor that will shut down the burner if the flue threshold temperature is exceeded;
- a safety valve which releases excess pressure from the primary circuit.

NOTE: when the appliance is first switched ON or when the electrical supply is interrupted then restored, the appliance will enter a short 'purge' cycle whereby the pump cycles ON & OFF for approximately 2-minutes. Only when the 'purge' cycle has been completed, will the appliance go through an ignition sequence.

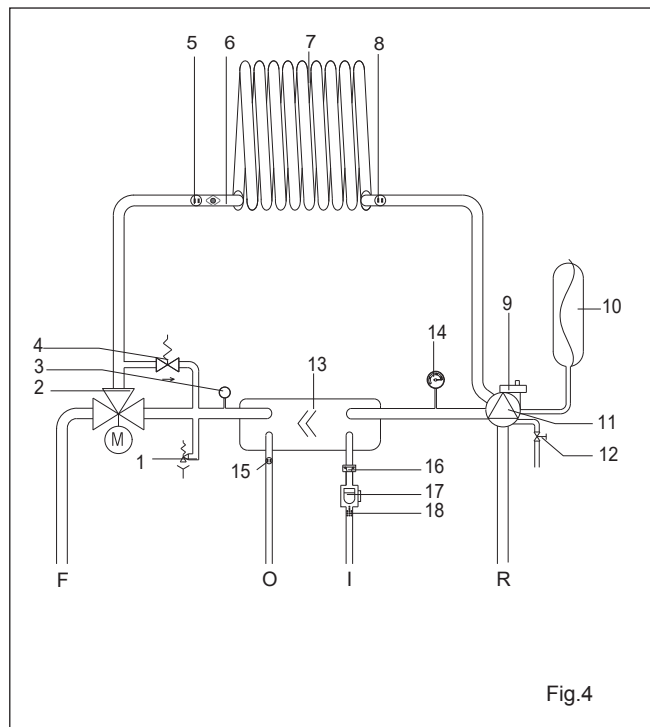

Fig.4

- 1 Safety valve
- 2 3-way valve
- 3 Pressure transducer
- 4 Automatic by-pass
- 5 NTC delivery probe
- 6 Limit thermostat
- 7 Exchanger
- 8 NTC return probe
- 9 Air vent valve
- 10 Expansion vessel
- 11 Circulator
- 12 Drain tap
- 13 DHW exchanger
- 14 Hydrometer
- 15 Domestic hot water NTC probe
- 16 Flow restrictor
- 17 Flow meter
- 18 DHW filter

- R Heating return connection
I Cold water inlet
O Hot water outlet
F Heating flow connection

2. SECTION - TECHNICAL DATA

2.1 CENTRAL HEATING	SYNERGY 25C	SYNERGY 30C	SYNERGY 35C
Heat input (kW)	20.00	25.00	30.00
Maximum heat output (kW) 60/80°C	19.53	24.42	29.28
Minimum heat output (kW) 60/80°C	2.34	2.87	3.36
Maximum heat output (kW) 30/50°C	21.31	26.51	31.75
Minimum heat output (kW) 30/50°C	2.57	3.19	3.71
Minimum working pressure	0.25±0.45 bar		
Maximum working pressure	3 bar		
Minimum flow rate	450 l/h		
2.2 DOMESTIC HOT WATER	SYNERGY 25C	SYNERGY 30C	SYNERGY 35C
Heat input (kW)	25.00	30.00	34.90
Flow Rate: ΔT35°C	10.2	12.3	14.3
Maximum inlet pressure	8 bar		
Minimum inlet pressure	0.5 bar		
Minimum flow rate	2 l/min		
Flow regulator	8 l/min	10 l/min	12 l/min
2.3 GAS PRESSURES	SYNERGY 25C	SYNERGY 30C	SYNERGY 35C
Inlet pressure (G20)	20.0 mbar	20.0 mbar	20.0 mbar
Heating maximum gas rate (m³/hr)	2.12	2.64	3.17
DHW maximum gas rate (m³/hr)	2.64	3.17	3.69
Minimum gas rate (m³/hr)	0.26	0.32	0.37
2.4 EXPANSION VESSEL	SYNERGY 25C	SYNERGY 30C	SYNERGY 35C
Capacity	9 litres		
Maximum system volume	74 litres		
Pre-charge pressure	1 bar		
2.5 DIMENSIONS	SYNERGY 25C	SYNERGY 30C	SYNERGY 35C
Height (mm)	740		
Width (mm)	420		
Depth (mm)	275		
Dry weight (kg)	29	30	30
2.6 CLEARANCES REQUIRED FOR MAINTENANCE	SYNERGY 25C	SYNERGY 30C	SYNERGY 35C
Sides	5mm*		
Top	150mm** from casing or 25mm above flue elbow (whichever is applicable)**		
Bottom	200mm [^]		
Front	420mm ^{^^}		
* It may be necessary to remove adjacent components if component removal/replacement is required			
** Consideration should be given to providing reasonable clearance for the insertion of a FGA probe.			
[^] This can be reduced to 4mm if a removal panel enables the required 200mm			
^{^^} When installed in a cupboard, this dimension can be reduced to 4mm provided that the required 420mm is available when the door is opened/ removed.			
2.7 CONNECTIONS	SYNERGY 25C	SYNERGY 30C	SYNERGY 35C
Flow & return	22mm		
Gas	15mm		
DHW hot & cold	15mm		
Safety valve	21mm		
Condense	21mm		
2.8 ELECTRICAL	SYNERGY 25C	SYNERGY 30C	SYNERGY 35C
Power consumption CH (Watts)	73	74	87
Power consumption DHW (Watts)	87	87	110
Voltage (V/Hz)	230/50		
Internal fuse	4 A T (for PCB) - 3.15A F (for connections block)		
External fuse	3A		
2.9 FLUE DETAILS (CONCENTRIC 60-100)	SYNERGY 25C	SYNERGY 30C	SYNERGY 35C
Maximum horizontal flue length (60/100mm)	10.0 m	8.0 m	8.0 m
Maximum vertical flue length (60/100mm)	11.0 m	9.0 m	9.0 m
2.10 EFFICIENCY	SYNERGY 25C	SYNERGY 30C	SYNERGY 35C
SEDBUK 2005 (%)	90.1	90.1	90.1
2.11 EMISSIONS	SYNERGY 25C	SYNERGY 30C	SYNERGY 35C
CO ₂ @ maximum output (%) (*)	8.8	8.8	8.8
CO ₂ @ minimum output (%) (*)	8.8	8.8	8.8
CO @ maximum output (ppm)	230	200	240
CO @ minimum output (ppm)	15	15	15
NO _x rating	class 6	class 6	class 6
(*) CO ₂ tolerance= +1% -1%			
2.12 FAN ROTATIONS	SYNERGY 25C	SYNERGY 30C	SYNERGY 35C
Maximum number of heating fan rotations (rpm)	6,300	6,200	7,400
Minimum number of heating fan rotations (rpm)	1,200	1,200	1,300
Maximum number of DHW fan rotations (rpm)	7,900	7,400	8,600
Minimum number of DHW fan rotations (rpm)	1,200	1,200	1,300
2.13 GAS PRESSURE	SYNERGY 25C	SYNERGY 30C	SYNERGY 35C
Nominal methane gas pressure (G20 - I2H)	20 mbar	20 mbar	20 mbar
Nominal methane-hydrogen gas pressure (G20.2 - I2Y20)	20 mbar	20 mbar	20 mbar
Nominal liquid gas LPG pressure (G31 - I3P)	37 mbar	37 mbar	37 mbar

Parameter	Symbol	25C	30C	35C	Unit
Seasonal space heating energy efficiency class	-	A	A	A	-
Water heating energy efficiency class	-	A	A	A	-
Rated heat output	Pnominal	20	24	29	kW
Seasonal space heating energy efficiency	η_s	94	94	94	%
Useful heat output					
At rated heat output and high-temperature regime (*)	P4	19,5	24,4	29,3	kW
At 30% of rated heat output and low-temperature regime (**)	P1	6,6	8,2	9,9	kW
Useful efficiency					
At rated heat output and high-temperature regime (*)	η_4	87,9	87,9	87,9	%
At 30% of rated heat output and low-temperature regime (**)	η_1	98,8	98,7	98,8	%
Auxiliary electricity consumption					
At full load	elmax	30,0	31,1	44,3	W
At part load	elmin	12,2	13,3	13,6	W
In Stand-by mode	PSB	3,0	3,0	3,0	W
Other parameters					
Stand-by heat loss	Pstby	30,0	35,0	35,0	W
Pilot flame energy consumption	Pign	-	-	-	W
Annual energy consumption	QHE	60	75	90	GJ
Sound power level, indoors	LWA	48	45	47	dB
Emissions of nitrogen oxides	NOx	22	20	35	mg/kWh
For combination heaters					
Declared load profile		XL	XL	XXL	
Water heating energy efficiency	η_{wh}	85	85	87	%
Daily electricity consumption	Qelec	0,173	0,138	0,130	kWh
Daily fuel consumption	Qfuel	23,014	23,010	27,951	kWh
Annual electricity consumption	AEC	38	30	28	kWh
Annual fuel consumption	AFC	17	17	22	GJ

(*) High-temperature regime means 60 °C return temperature at heater inlet and 80 °C feed temperature at heater outlet

(**) Low temperature means for condensing boilers 30 °C, for low-temperature boilers 37 °C and for other heaters 50 °C return temperature (at heater inlet)

Description	Boiler type SYNERGY C								
	25C	30C	35C	25C	30C	35C	25C	30C	35C
Technical data for typical installations:									
Temperature of combustion products @ Nominal heat output (at 80/60° C) - [°C]	63	62,2	63,8	63,5	64,2	63,9	49,7	55,2	56,3
Mass flow rate [kg/h] @ Nominal heat output [kW]	2,759	3,158	3,823	2,743	3,365	4,089	2,833	3,2618	3,944
Nominal heat output [kW]	25,8	30,15	35,67	25,55	30,96	38,4	26,46	31,02	36,82
Overtemperature of the flue gases [°C]	115								
Temperature of the flue gases at minimum heat output [°C]	35,6	37,2	39,5	57,6	58,5	60,1	35,8	36,6	37,4
Mass flow rate [kg/h] @ Minimum heat output [kW]	0,545	0,588	0,694	0,305	0,360	0,422	1,036	1,064	1,187
Minimum heat output [kW]	5,14	5,52	6,52	2,87	3,41	4	9,74	9,95	11,1
CO ₂ content @ Nominal heat output [%]	8,42	8,56	8,56	10,00	10,40	10,40	5,62	5,92	5,92
CO ₂ at minimum heat output [%]	3,12	3,06	3,04	9,08	9,12	9,26	2,65	2,52	2,56
Loss of minimum permitted pressure (in air feed and flue gas pipe) [Pa]	4,4	8,3	8,3	-	-	-	-	-	-
Loss of maximum permitted pressure (in air supply and flue gas pipe) [Pa]	180	195	195	-	-	-	-	-	-
Maximum permitted pressure difference between combustion air inlet and flue gas outlet (including wind pressure) [Pa]	-	-	-	4,4	8,3	8,3	-	-	-
Maximum permitted combustion air temperature [°C]	-	-	-	45	45	45	-	-	-
C9									
25C - 30C - 35C									
Minimum useful diameter of the flue/vertical technical compartment for combustion air supply [mm]	240								
Notes									
C1: for the installation of the terminals on the wall and roof, refer to the specific instructions contained in the kits the terminals emerge from separate combustion and air supply circuits within a square area of 50 cm									
C3: the terminals of the separate combustion and air supply circuits must lie within a square area of 50 cm, and the distance between the surfaces of the two holes must be less than 50 cm									
C4: the boilers in this configuration, with the relative connection pipes, can be connected to only one natural draught stack condensate flow inside the appliance is not permitted									
C5: the terminals for combustion air supply and the evacuation of flue gases must not be installed on opposite walls of the building									
C6: condensate flow inside the appliance is permitted maximum permitted recirculation rate of 10% in windy conditions the terminals for combustion air supply and the evacuation of flue gases must not be installed on opposite walls of the building.									
⚠ This type of configuration is not permitted in some countries; refer to the local regulations in force									
C8: condensate flow inside the appliance is not permitted									

Fig.5

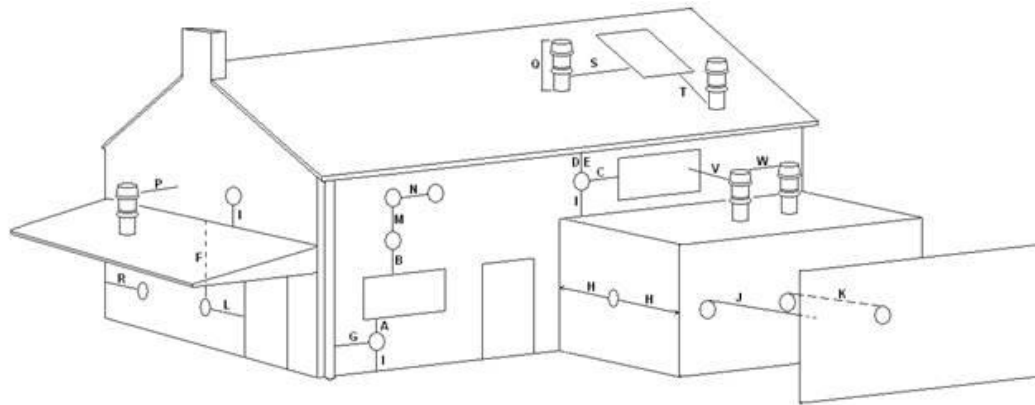

Key	Location	Minimum distance
A	Below an opening (window, air-brick, etc.)	300 mm
B	Above an opening (window, air-brick, etc.)	300 mm
C	To the side of an opening (window, air-brick, etc.)	300 mm
D	Below gutter, drain-pipe, etc.	25 mm
E	Below eaves	25 mm
F	Below balcony, lowest point of carport roof, etc.	25 mm
G	To the side of a soil/drain-pipe, etc.	25 mm (60mm for 80/125mm)
H	From internal/external corner	25 mm (60mm for 80/125mm)
I	Above ground, roof, or balcony level	300 mm
J	From a surface or boundary facing the terminal	600 mm*
K	From a terminal facing a terminal	1200 mm
L	From an opening in the car-port into the building	1200 mm
M	Vertically from a terminal on the same wall	1500 mm
N	Horizontally from a terminal on the same wall	300 mm
P	From a structure to the side of the vertical terminal	300 mm
Q	From the top of the vertical terminal to the roof flashing	As determined by the fixed collar of the vertical terminal
R	To the side of a boundary	300 mm
S	To the side of an opening or window on a pitched roof	600 mm
T	Below an opening or window on a pitched roof	2000 mm
V	From a vertical terminal to an adjacent opening (window, air-brick, etc.)	2000 mm
W	From a vertical terminal to an adjacent vertical terminal	300 mm (only if both terminals are the same height)

*The possibility that this may be deemed as causing a nuisance, should be considered

Circulator residual discharge head

The boiler is fitted with a high-efficiency circulator already hydraulically and electrically connected. The relative usable performance values are shown in the chart.

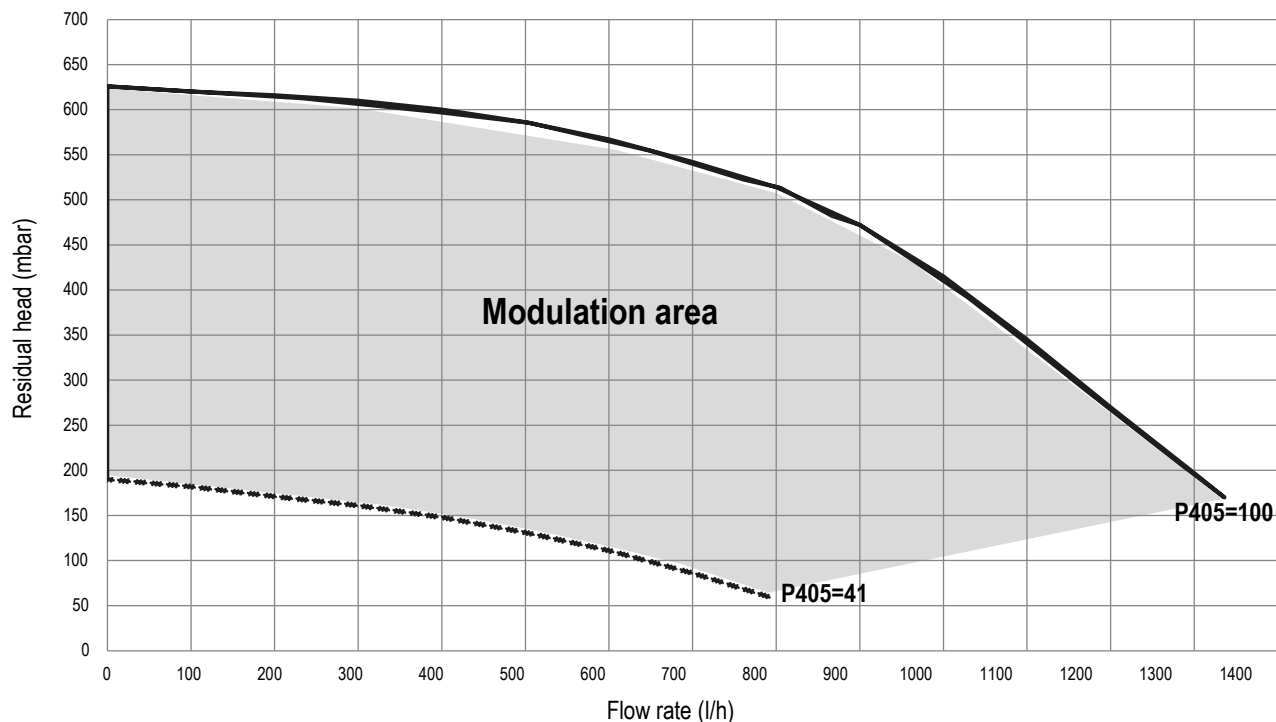

3. SECTION - GENERAL REQUIREMENTS (UK)

BS 5440	PART 1	FLUES
BS 5440	PART 2	FLUES & VENTILATION
BS EN 12828		DESIGN FOR WATER-BASED HEATING SYSTEMS
BS 5546		INSTALLATION OF GAS HOT WATER SUPPLIES FOR DOMESTIC PURPOSES
BS 6798		INSTALLATION OF BOILERS OF RATED INPUT NOT EXCEEDING 70kW
BS 6891		LOW PRESSURE INSTALLATION PIPES
BS 7074	PART 1	APPLICATION, SELECTION, AND INSTALLATION OF EXPANSION VESSELS AND ANCILLARY EQUIPMENT FOR SEALED WATER SYSTEM

This appliance must be installed by a competent person in accordance with the Gas Safety (Installation & Use) Regulations.

3.1 RELATED DOCUMENTS

The installation of this boiler must be in accordance with the relevant requirements of the Gas Safety (Installation & Use) Regulations, the local building regulations, the current I.E.E. wiring regulations, the bylaws of the local water undertaking, the Building Standards (Scotland) Regulation, and Building Standards (Northern Ireland) Regulations. It should be in accordance also with any relevant requirements of the local authority and the relevant recommendations of the following British Standard Codes of Practice.

ATTENTION

The use of PPE (Personal Protective Equipment) such as but not limited to gloves, mask, safety glasses, etc. is strongly recommended whenever carrying out the installation, repair, or maintenance of this appliance – please pay particular attention to:

- Sharp edges that may be encountered when:- handling or lifting the appliance, removing parts, etc. during installation and maintenance
- Airborne particles that may be released and/or disturbed when cleaning or removing components during maintenance
- Water treatment chemicals that could have been added to the system water may spill from the appliance and or components during maintenance

Please refer to an appropriate Health and Safety document such as HSE L23 (UK) or S.I. 299 (Ireland), for more detailed advice on safe working practices and procedures.

3.2 LOCATION OF APPLIANCE

The appliance may be installed in any room or internal space, although particular attention is drawn to the requirements of the current I.E.E. wiring regulations, and in Scotland, the electrical provisions of the Building Regulations, with respect to the installation of the appliance in a room or internal space containing a bath or shower. When an appliance is installed in a room or internal space containing a bath or shower, the appliance or any control pertaining to it must not be within reach of a person using the bath or shower (refer to IEE regs).

The location chosen for the appliance must permit the provision of a safe and satisfactory flue and termination. The location must also permit an adequate air supply for combustion purposes and an adequate space for servicing and air circulation around the appliance. Where the installation of the appliance will be in an unusual location special procedures may be necessary, BS 6798 gives detailed guidance on this aspect.

A compartment used to enclose the appliance must be designed and constructed specifically for this purpose. An existing compartment/cupboard may be utilised provided that it is modified to suit. Details of essential features of compartment/cupboard design including airing cupboard installations are given in BS 6798. This appliance is not suitable for external installation.

3.3 GAS SUPPLY

The gas meter – as supplied by the gas supplier – must be checked to ensure that it is of adequate size to deal with the maximum rated input of all the appliances that it serves. Installation pipes must be fitted in accordance with BS 6891.

Pipe work from the meter to the appliance must be of adequate size. Pipes of a smaller size than the appliance gas inlet connection must not be used. The installation must be tested for soundness in accordance with BS6891.

If the gas supply serves more than one appliance, it must be ensured that an adequate supply is maintained to each appliance when they are in use at the same time.

NOTE: It is recognised that 'pressure loss' through the gas cock and gas valve may result in a pressure drop of approximately 2mbar between the gas meter and gas valve inlet test point; this will not impair the performance of the appliance, provided that a dynamic pressure of 18mbar is available at the appliance inlet.

3.4 FLUE SYSTEM

The terminal should be located where the dispersal of combustion products is not impeded and with due regard for the damage and discoloration that may occur to building products located nearby. The terminal must not be located in a place where it is likely to cause a nuisance (see fig. 5).

In cold and/or humid weather, water vapour will condense on leaving the terminal; the effect of such plumbing must be considered. If installed less than 2m above a pavement or platform to which people have access (including balconies or flat roofs) the terminal must be protected by a guard of durable material. The guard must be fitted centrally over the terminal. Refer to BS 5440 Part 1, when the terminal is 0.5 metres (or less) below plastic guttering or 1 metre (or less) below painted eaves.

3.5 AIR SUPPLY

The following notes are intended for general guidance only. This appliance is a room-sealed, fan-flued boiler, consequently it does not require a permanent air vent for combustion air supply. When installed in a cupboard or compartment, ventilation for cooling purposes is also not required.

3.6 WATER CIRCULATION

Detailed recommendations are given in BS EN 12828 and BS 6798. The following notes are for general guidance only.

3.6.1 PIPEWORK

It is recommended that copper tubing to BS 2871 Part 1 is used in conjunction with soldered capillary joints. Where possible pipes should have a gradient to ensure air is carried naturally to air release points and that water flows naturally to drain cocks. Except where providing useful heat, pipes should be insulated to avoid heat loss and in particular to avoid the possibility of freezing. Particular attention should be paid to pipes passing through ventilated areas such as under floors, loft space, and void areas.

3.6.2 AUTOMATIC BY-PASS

The appliance has a built-in automatic by-pass, consequently there is no requirement for an external by-pass, however the design of the system should be such that it prevents boiler 'cycling'.

3.6.3 DRAIN COCKS

These must be located in accessible positions to facilitate draining of the appliance and all water pipes connected to the appliance. The drain cocks must be manufactured in accordance with BS 2879.

3.6.4 AIR RELEASE POINTS

These must be positioned at the highest points in the system where air is likely to be trapped. They should be used to expel trapped air and allow complete filling of the system.

3.6.5 EXPANSION VESSEL

The appliance has an integral expansion vessel to accommodate the increased volume of water when the system is heated. Refer to the specification table for more detailed information.

3.6.6 FILLING POINT

A method for initial filling of the system and replacing water lost during servicing etc. directly from the mains supply, is provided (see fig. 6). This method of filling complies with the current Water Supply (Water Fittings) Regulations 1999 and Water Bylaws 2000 (Scotland).

3.6.7 LOW PRESSURE SEALED SYSTEM

An alternative method of filling the system would be from an independent make-up vessel or tank mounted in a position at least 1 metre above the highest point in the system and at least 5 metres above the boiler (see fig. 7).

The cold feed from the make-up vessel or tank must be fitted with an approved non-return valve and stopcock for isolation purposes. The feed pipe should be connected to the return pipe as close to the boiler as possible.

3.6.8 FREQUENT FILLING

Frequent filling or venting of the system may be indicative of a leak. Care should be taken during the installation of the appliance to ensure all aspects of the system are capable of withstanding pressures up to at least 3 bar.

3.7 ELECTRICAL SUPPLY

The appliance is supplied for operation on 230V @ 50Hz electrical supply; it must be protected with a 3-amp fuse (supplied). The method of connection to the mains electricity supply must allow for complete isolation from the supply. The preferred method is by using a double-pole switch with a contact separation of at least 3mm. The switch must only supply the appliance and its corresponding controls, i.e. time clock, room thermostat, etc.

Warning!

This appliance must be earthed.

3.8 MOUNTING ON A COMBUSTIBLE SURFACE

The appliance can be mounted on a wall of combustible material without any requirement to fit any additional protective (fire-resistant) material.

3.9 TIMBER FRAMED BUILDINGS

If the appliance is to be fitted in a timber framed building, it should be fitted in accordance with the Institute of Gas Engineers publication (IGE/UP/7) 'Guide for Gas Installations in Timber Frame Buildings'.

3.10 WATER TREATMENT

Vokera recommend that water treatment be carried out in accordance with the Benchmark Guidance on water treatment in central heating systems. If water treatment products are to be used, then they must be entirely suitable for use with a stainless-steel heat exchanger. Any water treatment product, must be administered in strict accordance with the manufacturer's instructions.

If the appliance is to be installed to an existing system; water treatment and flushing of the complete heating system should be carried out in accordance with BS 7593 and the Benchmark Guidance on water treatment in central heating systems.

3.11 SHOWERS

If the appliance is intended for use with a shower, the shower should be thermostatically controlled and be suitable for use with a combination boiler.

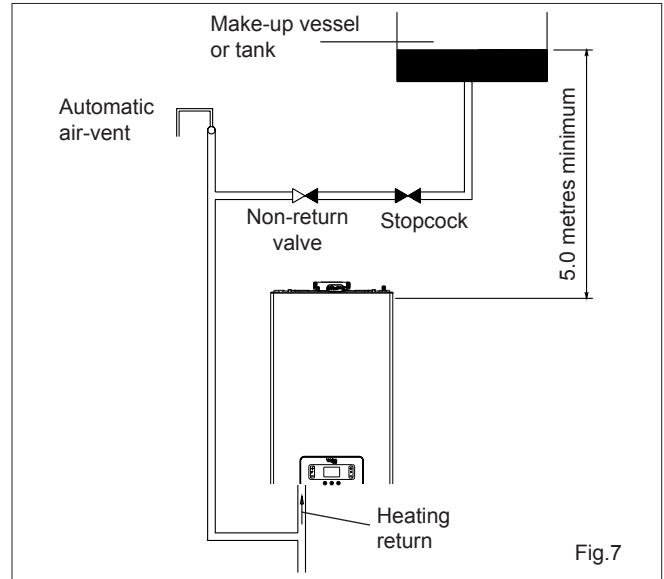
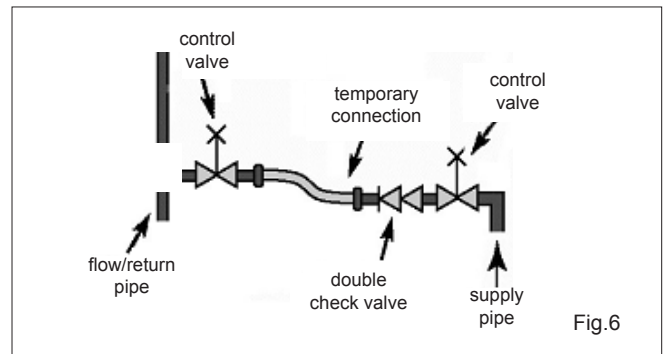

3A. SECTION - GENERAL REQUIREMENTS (EIRE)

This appliance must be installed by a competent person in accordance with and defined by, the Standard Specification (Domestic Gas Installations) Declaration (I.S. 813).

3A.1 RELATED DOCUMENTS

The installation of this boiler must be in accordance with the relevant requirements of the local building regulations, the current ETCI National Rules for Electrical Installations, and the bylaws of the local water undertaking. It should be in accordance also with any relevant requirements of the local and/or district authority.

ATTENTION

The use of PPE (Personal Protective Equipment) such as but not limited to gloves, mask, safety glasses, etc. is strongly recommended whenever carrying out the installation, repair, or maintenance of this appliance – please pay particular attention to:

- Sharp edges that may be encountered when:- handling or lifting the appliance, removing parts, etc. during installation and maintenance
- Airborne particles that may be released and/or disturbed when cleaning or removing components during maintenance
- Water treatment chemicals that could have been added to the system water may spill from the appliance and or components during maintenance

Please refer to an appropriate Health and Safety document such as HSE L23 (UK) or S.I. 299 (Ireland), for more detailed advice on safe working practices and procedures.

3A.2 LOCATION OF APPLIANCE

The appliance may be installed in any room or internal space, although particular attention is drawn to the requirements of the current ETCI National Rules for Electrical Installations, and I.S. 813, Annex K. When an appliance is installed in a room or internal space containing a bath or shower, the appliance or any control pertaining to it must not be within reach of a person using the bath or shower. The location chosen for the appliance must permit the provision of a safe and satisfactory flue and termination. The location must also permit an adequate air supply for combustion purposes and an adequate space for servicing and air circulation around the appliance. Where the installation of the appliance will be in an unusual location special procedures may be necessary, refer to I.S. 813 for detailed guidance on this aspect. A compartment used to enclose the appliance must be designed and constructed specifically for this purpose. An existing compartment/cupboard may be utilised provided that it is modified to suit.

This appliance is not configured for external installation.

3A.3 GAS SUPPLY

The gas meter – as supplied by the gas supplier – must be checked to ensure that it is of adequate size to deal with the maximum rated input of all the appliances that it serves. Installation pipes must be fitted in accordance with I.S. 813.

Pipe work from the meter to the appliance must be of adequate size. Pipes of a smaller size than the appliance gas inlet connection must not be used. The installation must be tested for soundness in accordance with I.S. 813.

If the gas supply serves more than one appliance, it must be ensured that an adequate supply is maintained to each appliance when they are in use at the same time.

NOTE: It is recognised that 'pressure loss' through the gas cock and gas valve may result in a pressure drop of approximately 2mbar between the gas meter and gas valve inlet test point; this will not impair the performance of the appliance, provided that a dynamic pressure of 18mbar is available at the appliance inlet.

3A.4 FLUE SYSTEM

The terminal should be located where the dispersal of combustion products is not impeded and with due regard for the damage and discoloration that may occur to building products located nearby. The terminal must not be located in a place where it is likely to cause a nuisance (see I.S. 813).

In cold and/or humid weather, water vapour will condense on leaving the terminal; the effect of such plumbing must be considered.

If installed less than 2m above a pavement or platform to which people have access (including balconies or flat roofs) the terminal must be protected by a guard of durable material. The guard must be fitted centrally over the terminal. Refer to I.S. 813, when the terminal is 0.5 metres (or less) below plastic guttering or 1 metre (or less) below painted eaves.

3A.5 AIR SUPPLY

The following notes are intended for general guidance only.

This appliance is a room-sealed, fan-flued boiler, consequently it does not require a permanent air vent for combustion air supply. When installed in a cupboard or compartment, ventilation for cooling purposes is also not required.

3A.6 WATER CIRCULATION

Specific recommendations are given in I.S. 813. The following notes are for general guidance only.

3A.6.1 PIPEWORK

It is recommended that copper tubing be used in conjunction with soldered capillary joints. Where possible pipes should have a gradient to ensure air is carried naturally to air release points and that water flows naturally to drain cocks. Except where providing useful heat, pipes should be insulated to avoid heat loss and in particular to avoid the possibility of freezing. Particular attention should be paid to pipes passing through ventilated areas such as under floors, loft space, and void areas.

3A.6.2 AUTOMATIC BY-PASS

The appliance has a built-in automatic by-pass, consequently there is no requirement for an external by-pass, however the design of the system should be such that it prevents boiler 'cycling'.

3A.6.3 DRAIN COCKS

These must be located in accessible positions to facilitate draining of the appliance and all water pipes connected to the appliance.

3A.6.4 AIR RELEASE POINTS

These must be positioned at the highest points in the system where air is likely to be trapped. They should be used to expel trapped air and allow complete filling of the system.

3A.6.5 EXPANSION VESSEL

The appliance has an integral expansion vessel to accommodate the increased volume of water when the system is heated. Refer to the specification table for more detailed information.

3A.6.6 FILLING POINT

A method for initial filling of the system and replacing water lost during servicing etc. is provided (see fig. 6). You should ensure this method of filling complies with the local water authority regulations.

3A.6.7 LOW PRESSURE SEALED SYSTEM

An alternative method of filling the system would be from an independent make-up vessel or tank mounted in a position at least 1 metre above the highest point in the system and at least 5 metres above the boiler (see fig. 7). The cold feed from the make-up vessel or tank must be fitted with an approved non-return valve and stopcock for isolation purposes. The feed pipe should be connected to the return pipe as close to the boiler as possible.

3A.6.8 FREQUENT FILLING

Frequent filling or venting of the system may be indicative of a leak. Care should be taken during the installation of the appliance to ensure all aspects of the system are capable of withstanding pressures up to at least 3 bar.

3A.7 ELECTRICAL SUPPLY

The appliance is supplied for operation on 230V @ 50Hz electrical supply; it must be protected with a 3-amp fuse (supplied). The method of connection to the mains electricity supply must allow for complete isolation from the supply. The preferred method is by using a double-pole switch with a contact separation of at least 3mm. The switch must only supply the appliance and its corresponding controls, i.e. time clock, room thermostat, etc.

Warning!

This appliance must be earthed.

3A.8 MOUNTING ON A COMBUSTIBLE SURFACE

The appliance can be mounted on a wall of combustible material without any requirement to fit any additional protective (fire-resistant) material.

3A.9 TIMBER FRAMED BUILDINGS

If the appliance is to be fitted in a timber framed building, it should be fitted in accordance with I.S. 813 and local Building Regulations. The Institute of Gas Engineers publication (IGE/UP/7) 'Guide for Gas Installations in Timber Frame Buildings' gives specific advice on this type of installation.

3A.10 WATER TREATMENT

Vokera recommend that water treatment be carried out in accordance with the Benchmark Guidance on water treatment in central heating systems. If water treatment products are to be used, then they must be entirely suitable for use with a stainless-steel heat exchanger. Any water treatment product, must be administered in strict accordance with the manufacturer's instructions. If the appliance is to be installed to an existing system; water treatment and flushing of the complete heating system should be carried out in accordance with BS 7593 and the Benchmark Guidance on water treatment in central heating systems.

3A.11 SHOWERS

If the appliance is intended for use with a shower, the shower should be thermostatically controlled and be suitable for use with a combination boiler.

3A.12 DECLARATION OF CONFORMITY

A Declaration of Conformity (as defined in I.S. 813) must be provided on completion of the installation.

A copy of the declaration must be given to the responsible person and also to the gas supplier if required.

This appliance must be installed by a competent person in accordance with and defined by, the Standard Specification (Domestic Gas Installations) Declaration (I.S. 813).

4. SECTION - INSTALLATION

NOTE

Please refer to 3/3A and use the appropriate PPE when carrying out any of the actions or procedures contained within this section.

4.1 PREPARATION FOR MOUNTING THE APPLIANCE

The appliance should be mounted on a smooth, vertical surface, which must be capable of supporting the full weight of the appliance. Care should be exercised when determining the position of the appliance with respect to hidden obstructions such as pipes, cables, etc.

When the position of the appliance has been decided – using the template supplied – carefully mark the position of the anchor holes (see Fig. 8) and flue-hole (if applicable).

Ensure that the anchors are securely fixed to support the appliance weight.

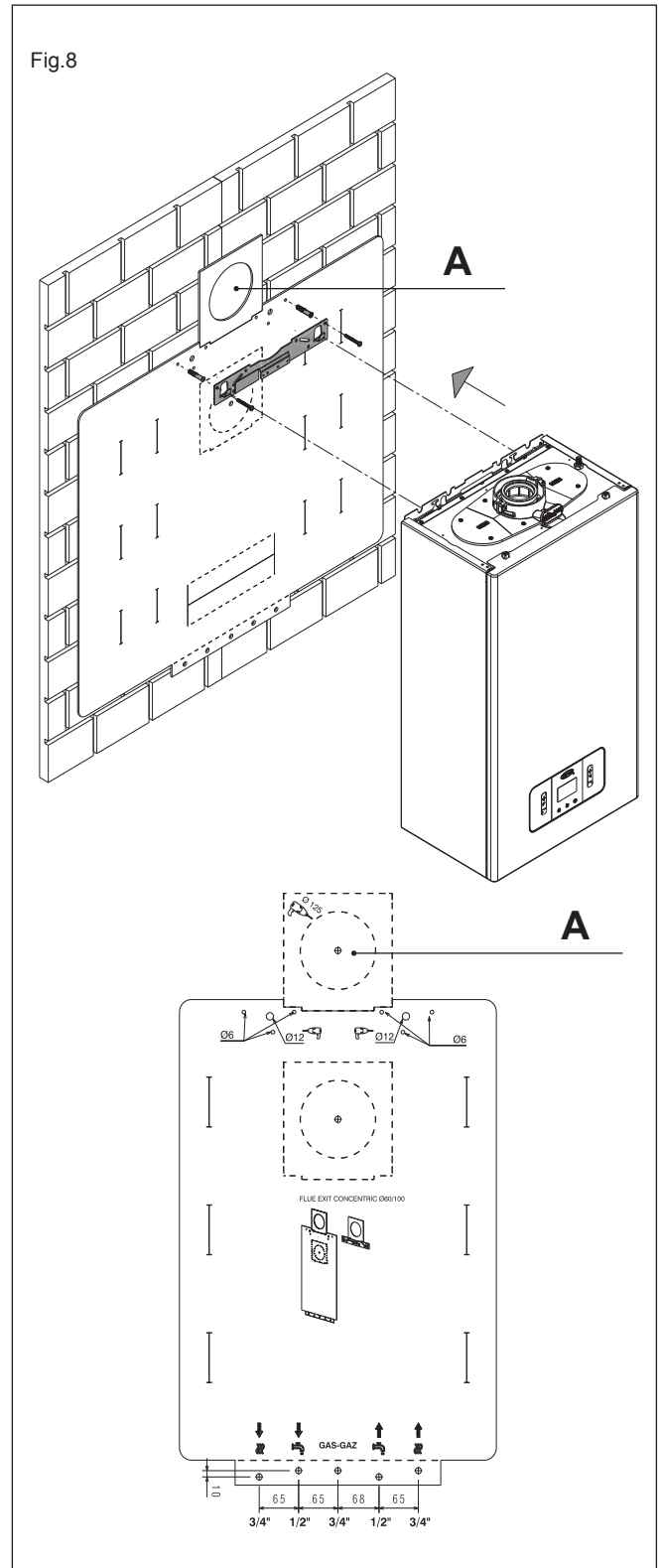

4.2 FITTING THE FLUE

This appliance incorporates a 'click-fit' flue connection at the top of the appliance.

NOTE: The boiler flue gas exhaust turret is sized for a concentric pipe with an external diameter of the flue gas pipe 60 +0.6 -0.3 mm and an external diameter of the air pipe 100 +0.3 -0.7 mm. Make sure the coupling is watertight.

4.2.1 CONCENTRIC HORIZONTAL FLUE

These instructions relate specifically to the installation of this appliance with the Vokera 60/100mm 'X-type' (click-fit) flue terminals accessories. For specific instructions on installing this appliance with an alternative Vokera flue system, e.g. 80/125mm; please refer to the instructions supplied with the specific flue system, or download the instructions from the Vokera website. The appliance flue outlet elbow can be rotated through 360° on its vertical axis. In addition the flue may be extended from the outlet elbow in the horizontal plane. A reduction must also be made to the maximum length (see table below) when additional bends are used.

Reduction for additional bends

Bend	Reduction in maximum flue length for each bend
45° bend	1.3 metre
90° bend	1.6 metre

Horizontal/Vertical flue terminals and accessories

Part No.	Description	Length/Size
20122759	XF Horizontal 'Click fit' Flue Kit	796mm C/E
20122761	XT Telescopic 'Click fit' Flue Kit	400-575mm C/E
20122763	XV Vertical 'Click fit' Flue Kit	1000mm + VC
20132060	0.5-Metre Extension	500mm
20132061	1.0-Metre Extension	1000mm
20132062	2.0-Metre Extension	2000mm
20132059	90-Degree Bend	N/A
20132058	45-Degree Bend x 2	N/A
20131979	Telescopic Extension	372/519mm
20142842	PMK Plume Kit	1370mm
20142841	45° Plume divertor	N/A
20132050	Pitched Roof Flashing	500mm x 500mm
20135582	Flat Roof Flashing	340mm Dia.
20135587	Wall Brackets	208mm C/E
20121903	Vert. Connector 'Click Fit' VC	131mm

Fig. 8: referring to position **A**, mark and drill a hole for the passage of the flue pipe. Both horizontal terminals (fixed & telescopic) have an eccentric configuration, that enables condense fluid to drain back to the appliance; consequently the terminals should be installed level.

NOTE: any horizontal runs that incorporate extensions, must have a 3-degree fall-back to the appliance.

NOTE: Minimum horizontal flue length = 0.35m.

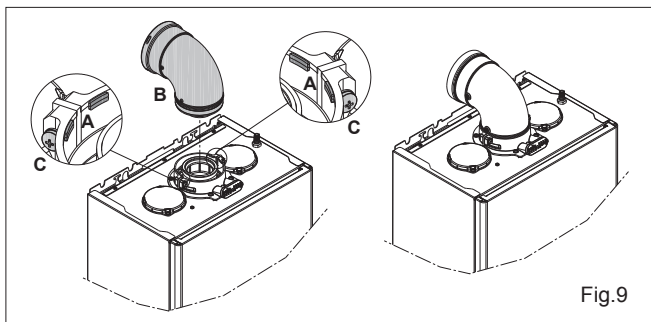

Fig.9

4.2.2 FITTING THE HORIZONTAL FLUE KIT

Carefully measure the distance from the centre of the appliance flue outlet to the edge of the finished outside wall (dimension X). Add 65mm to dimension X to give you Dimension Y (see Fig.10). Measure dimension Y from the terminal end of the concentric flue pipe and cut off the excess ensuring any burrs are removed. Pass the concentric flue pipe through the previously drilled hole. Fit the flue bend to the boiler flue outlet and insert the concentric flue pipe into the flue bend ensuring the correct seal is made.

NOTE (Fig.9): The appliance incorporates a 'click-fit' flue connection. Ensure that both screws 'C' on the 'click-fit' have been slackened off. Ensure that the connector is correctly aligned with the 'click-fit' and insert it into the 'click-fit' until it clicks into position (this is when the tabs at points 'A' are located in the groove of the flue bend connector). Both screws (C) should now be tightened.

NOTE

Fit the internal (white) trim to the flue assembly prior to connecting the flue pipe to the bend.

You must ensure that the entire flue system is properly supported and connected. Seal the flue assembly to the wall using cement or a suitable alternative that will provide satisfactory weatherproofing. The exterior trim can now be fitted.

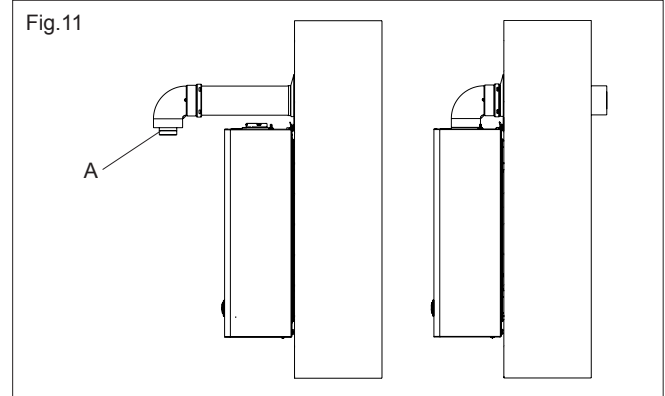
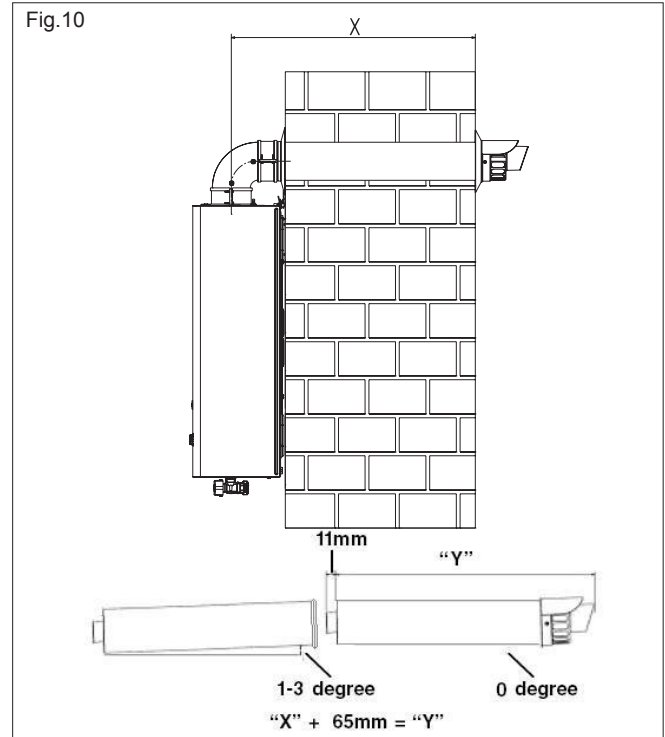

4.2.3 EXTENDING THE FLUE

Connect the bend – supplied with the terminal kit – to the top of the boiler (see Fig. 9). The additional bends & extensions have push-fit connections, care should be taken to ensure that the correct seal is made when assembling the flue system. Connect the required number of flue extensions or bends (up to the maximum equivalent flue length) to the flue terminal (Fig.12). The flue system should have a 3° rise from the boiler to outside, to ensure any condense fluid that forms, is allowed to drain back to the appliance.

NOTE

When cutting an extension to the required length, you must ensure that the excess is cut from the plain end of the extension (Fig.12). Remove any burrs, and check that all seals are located properly. You must ensure that the entire flue system is properly supported and connected. Seal the flue assembly to the wall using cement or a suitable alternative that will provide satisfactory weatherproofing. The interior and exterior trim can now be fitted.

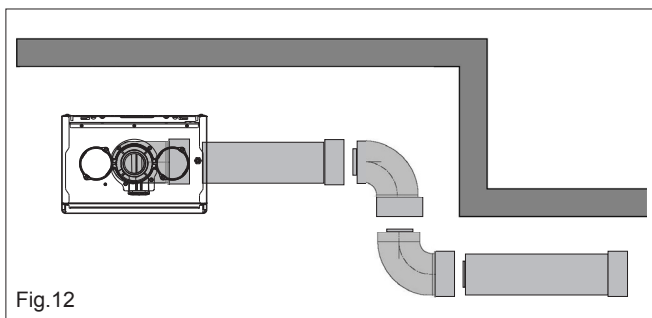

Fig.12

4.2.4 CONCENTRIC VERTICAL FLUE

Using Fig.14 as a reference, cut a 110mm diameter hole in the roof and/or ceiling to facilitate the route of the vertical flue system. **NOTE:** ensure that the top of the appliance - if already in position - is covered and protected from the possibility of any dust or debris falling or entering the appliance via the flue outlet.

Fit the appropriate flashing to the roof and insert the vertical flue terminal through the flashing from outside, ensuring that the collar of the terminal is located over the outlet of the flashing.

The fixing holes for the appliance wall mounting bracket should now be drilled and plugged. An appropriate type and quantity of fixing should be used to ensure that the bracket is mounted securely. Once the bracket has been secured to the wall, mount the appliance onto the bracket.

If the vertical flue system requires additional extensions or bends, connect these to the vertical terminal, ensuring the following:

- the maximum permitted flue length is not exceeded
- reductions to the maximum flue length have been made for any bends that are used on the vertical flue system
- any horizontal sections of the flue system, incorporate a 3-degree fallback to the appliance
- the entire flue system is fully supported and secured using the appropriate brackets
- if/when an extension is cut to a shorter length, ensure that the excess length is cut from the plain end of the extension, and that any burrs or rough edges are removed
- all seals are properly located before assembling or connecting the flue system.

IMPORTANT: The VX flue terminal is supplied with a sachet of silicone lubricant; smear a small amount of the lubricant around both inner and outer connections, at both ends of the vertical flue connector (supplied with the VX terminal).

NOTE (Fig.13): The appliance incorporates a 'click-fit' flue connection. Ensure that both screws 'C' on the 'click-fit' have been slackened off. Ensure that the connector is correctly aligned with the 'click-fit' and insert it into the 'click-fit' until it clicks into position (this is when the tabs at points 'A' are located in the groove of the vertical flue connector). Both screws (C) should now be tightened.

NOTE: If more convenient, the vertical flue connector can be attached to the vertical flue terminal/extension before connecting it to the appliance.

NOTE: Minimum length of vertical flue = 2m.

NOTE: Additional bends and/or extensions can be connected to the terminal connector if desired, however if additional bends are fitted, a reduction must be made to the maximum flue length (see table below).

Reduction for bends

Bend	Reduction in maximum flue length for each bend
45° bend	1.3 metre
90° bend	1.6 metre

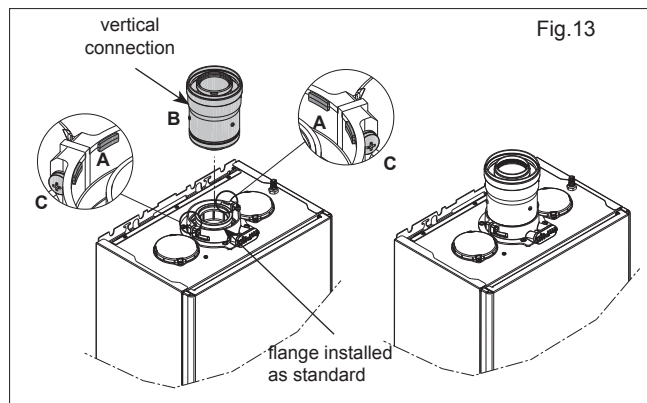

Fig.13

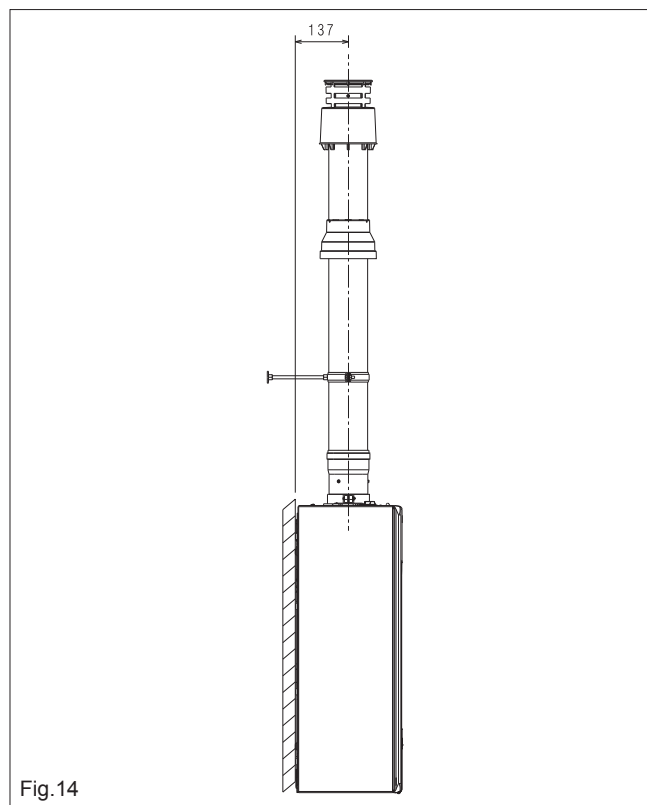

Fig.14

IMPORTANT

The vertical flue terminal is 1.0 metre in length and cannot be cut; therefore it may be necessary to adjust the height of the appliance to suit or use a suitable extension.

4.3 CONNECTING THE GAS & WATER (FIG. 15)

The appliance is supplied with an accessory pack that includes service valves. The service valves are of the compression type. The accessory pack contains sealing washers etc, for use with the service valves. When connecting pipe work to the valves, tighten the compression end first then insert the sealing washers before tightening the valve to the appliance.

NOTE: it will be necessary to hold the valve with one spanner whilst tightening with another.

The valves must be fitted perpendicular with the rear of the appliance, in order to avoid obstruction and ensure that the filling loop attaches correctly.

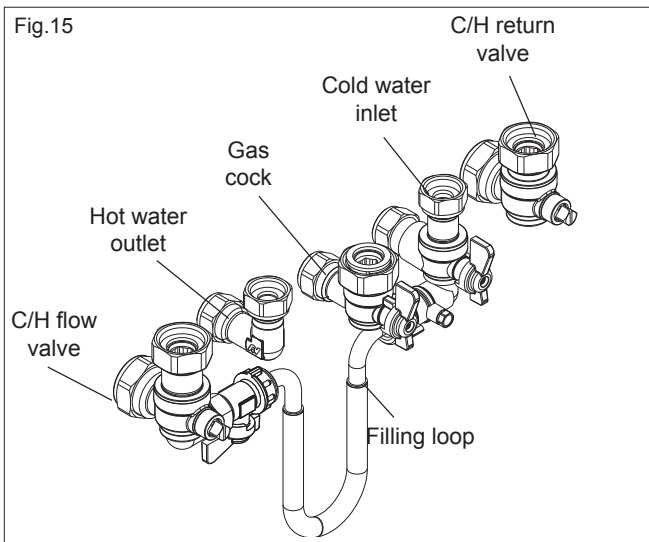

4.3.1 GAS

The appliance is supplied with a 15mm service valve, connect a 15mm pipe to the inlet of the valve and tighten both nuts.

NOTE: it will be necessary to calculate the diameter of the gas supply pipe to ensure the appliance has an adequate supply of gas.

4.3.2 FLOW & RETURN

The appliance is supplied with 22mm service valves for the flow and return connections, connect a 22mm pipe to the inlet of each valve and tighten both nuts.

NOTE: depending on system requirements, it may necessary to increase the size of the flow & return pipe work after the service valve connections.

4.3.3 COLD WATER INLET

The appliance is supplied with a 15mm combined stopcock and filling valve, connect a 15mm pipe to the inlet of the stopcock and tighten both nuts.

4.3.4 HOT WATER OUTLET

The appliance is supplied with a 15mm outlet connection, connect a 15mm pipe to the outlet connection and tighten both nuts.

4.3.5 SAFETY VALVE

The appliance incorporates a combined pressure relief and condensate discharge arrangement. Consequently the combined discharge pipe must have a continuous fall away from the appliance and should be suitably protected against the risk of freezing.

Alternatively it is permissible to fit a tundish, e.g. Mactun, Hotun, etc. close to or adjacent to the discharge pipe where it exits the appliance.

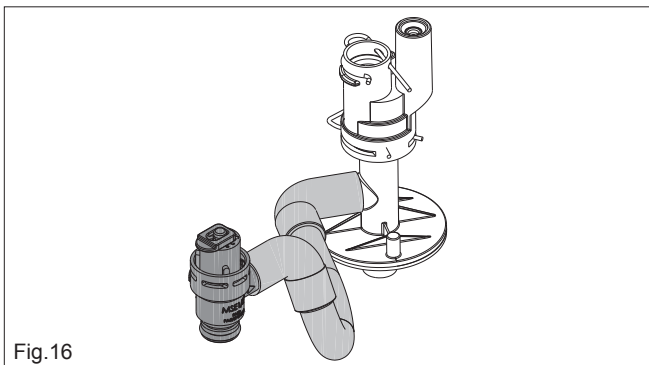

4.3.6 CONDENSE PIPE

This appliance will - under normal operating conditions - produce condensate fluid that will require to be disposed of via the dwelling's waste water drainage system. Vokera strongly recommends that the condensate pipe is connected to the internal waste water pipework in accordance with BS6798.

BS6798 provides comprehensive instruction and advice on all permissible condensate disposal methods; notwithstanding this, it is essential that the following is strictly adhered to:

- use only plastic drainage pipe (minimum OD of 21.5mm)
- horizontal runs must incorporate a minimum 45mm fall per metre, away from the appliance

- external pipework and/or pipework in unheated areas, must have a minimum OD of 32mm and be insulated with Class-O pipe insulation
- the route, type, and termination of the condensate disposal method, must not permit any spillage of condensate fluid, into the dwelling in the event of a blockage or freezing of the condensate pipework
- if there is a risk of freezing, Vokera strongly recommends that a tundish is incorporated within the discharge pipework (see section 4.3.5 above).

Should it not be possible to route and terminate the condensate pipework internally using 'gravity discharge'; Vokera recommends that the Vokera condensate pump (code 404) be considered as an alternative solution.

Ensure that the end-user is aware of the effect/consequences of the condensate pipework becoming blocked or frozen.

4.3.7 INSTRUCTION FOR CONDENSATION EXHAUST CONNECTION



All components of the product condensation drain system must be properly maintained in accordance with the manufacturer instructions and cannot be modified in any way.

This product is designed to prevent the escape of gaseous products of combustion through the condensation drain pipe with which it is equipped, this is obtained by using a special siphon placed inside the appliance. The construction of the condensation exhaust system downstream of the appliance is the responsibility of the installer. The condensation exhaust system must be dimensioned and installed in such a way as to guarantee the correct evacuation of the condensation produced by the appliance and/or collected by the evacuation systems of combustion products. All the components of the condensation exhaust system must be made in a workmanlike manner using materials that are suitable for withstanding the mechanical, thermal and chemical stresses of the condensation produced by the appliance over time. Note: if the condensation exhaust system is exposed to the risk of frost, always provide an adequate level of insulation of the pipe and consider any increase in the diameter of the pipe itself. The condensation exhaust pipe must always have an adequate slope level to prevent the condensation from stagnating and its proper drainage. The condensation exhaust system must have an inspectable disconnection between the condensation exhaust pipe of the appliance and the condensation exhaust system.

4.4 ELECTRICAL CONNECTIONS

The boiler is supplied with a short fly-lead. This lead can be used for connection to the electrical supply. Connect the fly-lead to a fused isolator in the following way:

- brown wire to LIVE supply
- blue wire to NEUTRAL supply
- green/yellow to EARTH connection.

Insert the supplied 3-AMP fuse into the fused isolator.

Should the fly-lead be unsuitable, refer to 4.6 for details on how to connect the electrical supply directly to the boiler.

The electrical supply must be as specified in section 3/3A. A qualified electrician should connect the appliance to the electrical supply. If controls - external to the appliance - are required, a competent person must undertake the design of any external electrical circuits, please refer to section 10 for detailed instructions. ANY EXTERNAL CONTROL OR WIRING MUST BE SERVED FROM THE SAME ISOLATOR AS THAT OF THE APPLIANCE. The supply cable from the isolator to the appliance must be 3-core flexible seized 0.75mm to BS 6500 or equivalent. Wiring to the appliance must be rated for operation in contact with surfaces up to 90°C.

NOTE:

- See pages 22 & 41 for wiring of typical external controls into connector CE8
- Do not connect 230V to any of the CE8 terminals
- Do not remove the white link wire from TBT unless it's to be used to connect an approved control

MODBUS CONNECTION - CE4

The CE4 connector is located on the underside of the appliance towards the front left.

 We recommend using conductors with a section no larger than 0,5 mm².

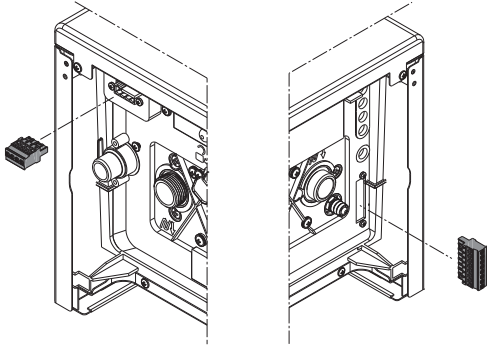

CE8 LOW-VOLTAGE CONNECTIONS

The CE8 low-voltage connector is located on the underside of the appliance; at the rear of the right hand side. There are 4-pairs of connectors:

- >TBT - Safety or alarm connector
- >TA - External control (clock, etc.)
- >OT+ - Opentherm
- >SE - External sensor

NOTE: when an OT+ remote control is connected to the system, if parameter 803=1 (SERVICE), the boiler display shows the following screen:

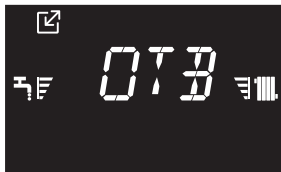

In particular on the boiler display:

- it is no longer possible to set the boiler OFF/WINTER/SUMMER status (it is set by the OT+ remote control)
- it is no longer possible to set the domestic hot water setpoint (it is set by the OT+ remote control)
- the combination of the **A+B** keys remains active for the setting of the DOMESTIC HOT WATER COMFORT function
- the domestic hot water setpoint (I005) is displayed in the INFO menu
- the heating setpoint value calculated by the OT+ remote control (I017) is displayed in the INFO menu
- the heating setpoint set on the boiler display is used only if there are heat requests from the TA and the OT+ remote control does not have a request if the parameter: 311 = 1. This value is displayed in the INFO menu (I016).
- to activate the "Combustion analysis" function with an OT+ remote control connected, you must temporarily disable the connection by setting the parameter 803 = 0 (SERVICE); remember to reset this parameter once the function has finished.

Key 3 remains active for the visualisation of the INFO menu and the enabling of the SETTINGS menu.

4.5 CASING REMOVAL

To gain internal access to the appliance you must first remove the front cover, proceed as outlined below:

- locate and unscrew the 2-screws that secure the front cover to the appliance
- Disengage both clips at 1A to release the lower part of the front cover
- lift the cover upward to disengage it from the top locating hooks and then remove
- store the cover and screws safely until required. Re-fit in the reverse order
- press and hold the spring tabs on either side of the control panel where it meets the appliance side panels and gently lower it until it rests.

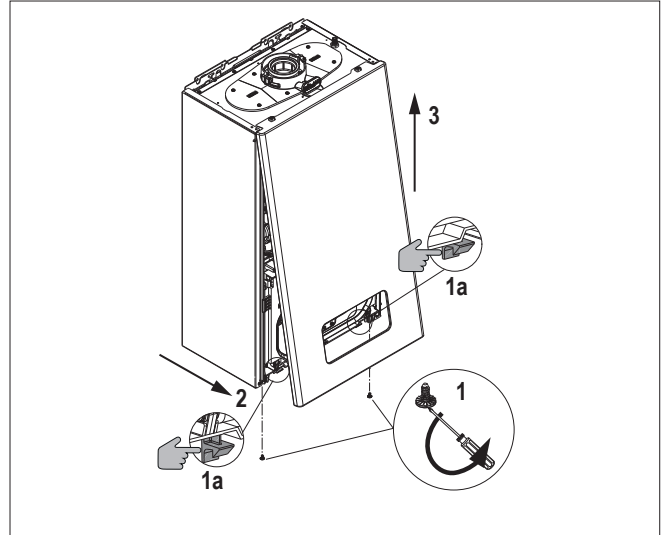

4.6 CONNECTING THE MAINS (230V) INPUT

Unhook and remove the terminal block cover (230V).

Pass the cable through the cable anchorage point. Connect the supply cable wires (LIVE, NEUTRAL, & EARTH) to their corresponding terminals (L, N, & E) on the appliance – high voltage – terminal block (M3). When connecting the EARTH wire, ensure that it's left slightly longer than the others, this will prevent strain on the EARTH wire should the cable become taut. Route the electrical supply via the cable entry/exit point and secure to the sleeve using an appropriate cable tie, and/or silicone sealant.

The appliance comes with a factory fitted link ('TA') to allow basic operation of the boiler via the mode selector switch. If it is anticipated that external controls will be required please refer to the wiring diagrams in section 10 for more detailed information.

NOTE

It is the installer's responsibility to ensure that the appliance is properly Earthed. Vokèra Ltd. cannot be held responsible for any damages or injuries caused as a result of incorrect Earth wiring.

ATTENTION

- Do not connect any high voltage (230V) power to the connections on CE4 or CE8
- Connect the Vokera external sensor to the SE connections on plug CE8 or terminals 3 & 4 (orange) on X18 of the PCB (see also 4.4)
- Connect the Opentherm control, e.g. Hi COMFORT to the OT+ connections on plug CE8 or terminals 5 & 6 (red) on X18 of the PCB (see also 4.4)
- The TA connections on plug CE8 and terminals 7 & 8 (black) of X18 are 'voltage-free' and MUST only be used to switch a 'voltage-free' external control, e.g. 2-wire room thermostat
- Do not remove the white link-wire from plug CE8

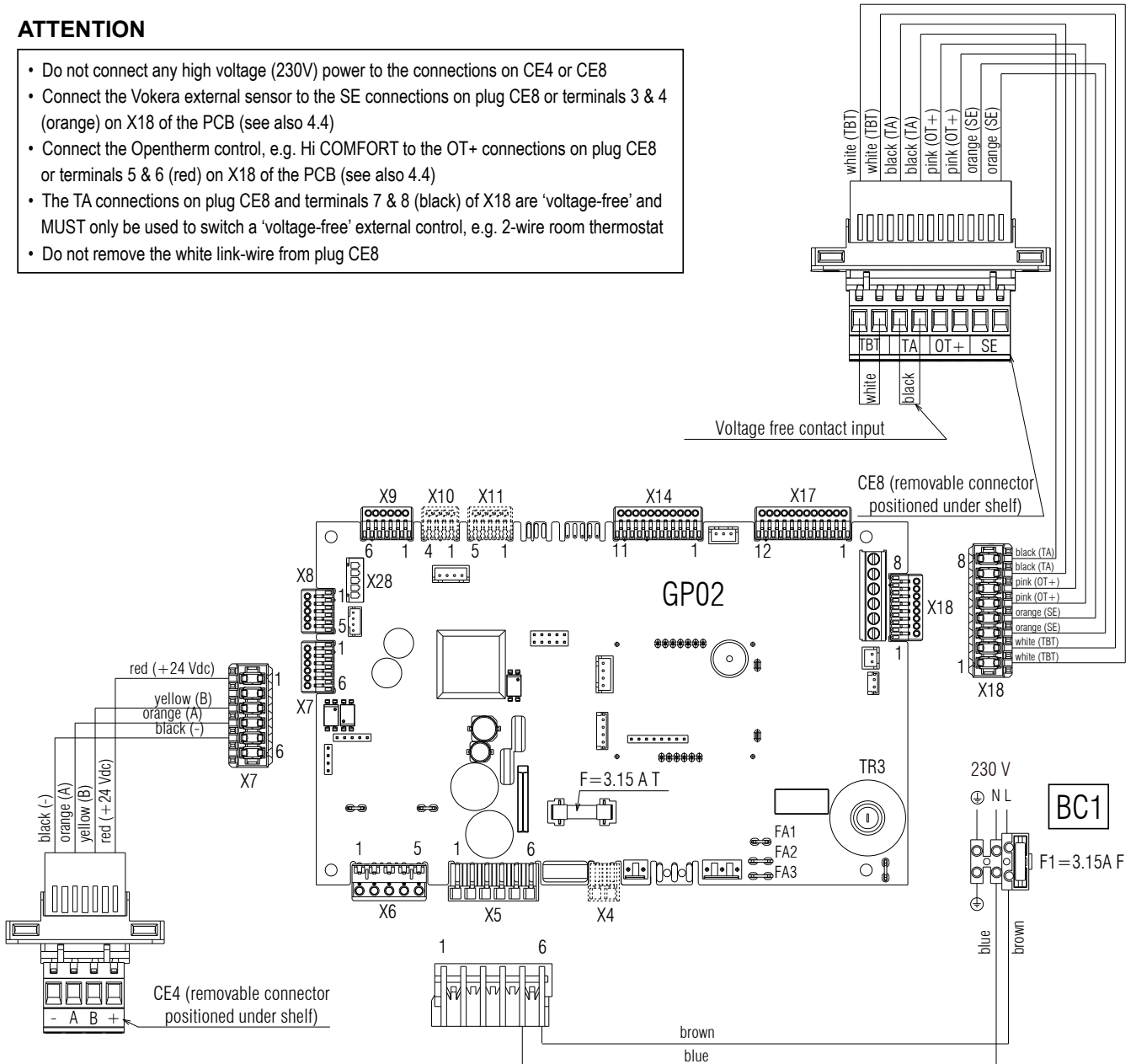

ACCESSORIES

	X4	L-N antifreeze heaters
	CE8	TA: (room thermostat)
	CE8	OT+
	CE8	SE (outdoor temperature sensor)
	CE8	TBT: Low temperature limit thermostat
	X10	Alarm remote function
	X11	Zone valve or additional pump

NOTE

- A 230V supply – if required for a clock motor or similar – can be taken from the electrical isolator that serves the appliance, or alternatively from the block connector (BC1) shown above
- Remove the black link-wire from plug CE8 if an external control is fitted
- See 4.6 if the supplied 'fly-lead' is unsuitable or of insufficient length
- Please contact the Vokera technical helpline (0330 236 8630) if you require further information on any of the above

5. COMMISSIONING & OPERATION

NOTE: please refer to 3/3A and use the appropriate PPE when carrying out any of the actions or procedures contained within this section.

5.1 GAS SUPPLY INSTALLATION

Inspect the entire installation including the gas meter, test for tightness and purge. Refer to BS 6891 (I.S. 813 in ROI) for specific instruction.

5.2 THE HEATING SYSTEM

The appliance contains components that may become damaged or rendered inoperable by oils and/or debris that are residual from the installation of the system, consequently it is essential that the system be flushed in accordance with the following instructions.

5.3 INITIAL FILLING OF THE SYSTEM

Ensure both flow and return service valves are open, remove appliance casing as described in 4.5, identify the automatic air release valves (AAV) and loosen the dust cap/s by turning the cap anti-clockwise one full turn. Ensure all manual air release valves located on the heating system are closed. Connect the filling loop (not supplied), slowly proceed to fill the system by firstly opening the inlet valve connected to the flow pipe, and then turning the lever on the fill valve, to the open position. As water enters the system the pressure gauge will begin to rise. Once the gauge has reached 1 BAR close both valves and begin venting all manual air release valves, starting at the lowest first. It may be necessary to go back and top-up the pressure until the entire system has been filled. Inspect the system for water tightness, rectifying any leaks.

5.4 INITIAL FLUSHING OF THE SYSTEM

The whole of the heating system must be flushed both cold and hot as detailed in 5.6. Open all radiator or heating valves and the appliance flow & return service valve. Drain the boiler and system from the lowest points. Open the drain valve full bore to remove any installation debris from the boiler prior to lighting. Refill the boiler and heating system as described in 5.3.

5.5 PRELIMINARY CHECKS

Before starting up the boiler, check:

- confirm via the appliance data badge, that the appliance is suitable/configured for the gas type and electrical supply that has been provided to the appliance
- inspect the entire flue system and ensure that it has been installed in accordance with these instructions and the relevant standards that apply locally and/or nationally
- that the required clearances have been met in respect of the requirements for maintenance
- inspect the entire installation including the gas meter, test for tightness and purge. Refer to BS 6891 (I.S. 813 in ROI) for specific instruction
- ensure that the rated delivery of the gas meter is adequate enough to serve this appliance and any other gas appliance connected to the same meter
- ensure that the gas supply pipework is of adequate size to provide the maximum gas rate required by this appliance
- check that the siphon is completely filled with water, otherwise fill it up (see chapter 5.7).



Before connecting the “Hi, Comfort T300 or K100” devices, it is necessary to correctly set P801=2 (in the P8 CONNECTIVITY menu) to avoid communication error problems as indicated in paragraph 8.11.

5.6 FINAL FLUSHING OF THE HEATING SYSTEM

The system shall be flushed in accordance with BS 7593 (I.S. 813 ROI). Should a cleanser be used, it must be suitable for stainless-steel heat exchangers. It shall be from a reputable manufacturer and shall be administered in strict accordance with the manufacturers' instructions and the DWTa code of practice.

NOTE: Chemicals used to cleanse the system and/or inhibit corrosion must be pH neutral, i.e. they should ensure that the level of the pH in the system water remains neutral. Premature failure of certain components can occur if the level of pH in the system water is out-with normal levels.

5.7 FIRST COMMISSIONING

On first ignition after prolonged inactivity and after maintenance, before putting the appliance into operation it is essential to fill the condensate collection siphon by pouring about 1 litre of water into the boiler combustion analysis take-off and check:

- that the float within the trap is free and moving
- the correct flow of water from the boiler outlet discharge pipe
- there are no leaks of the condensate drain connection line.

Correct operation of the condensate drain circuit (siphon and pipes) requires that the condensate level does not exceed the maximum level (max). Prior filling of the siphon and the presence of the safety float inside the siphon is designed to prevent the escape of combustion gases into the environment.

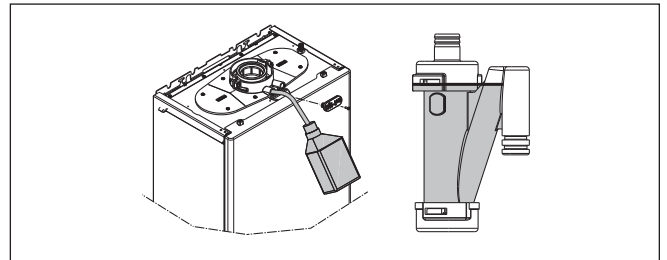

High efficiency mode

The boiler is equipped with an automatic function that is activated at the first power supply or after 60 days of non-use (electrically powered boiler). In this mode the boiler, for 60 minutes, limits the heating power to a minimum and the maximum DHW temperature to 55°C. Activating the chimney sweep temporarily disables this function.

During execution, the water pressure icon flashes and the display shows:



5.8 VENTING CYCLE

Each time the Appliance is “powered” a 4-minute vent cycle is performed and the display shows:

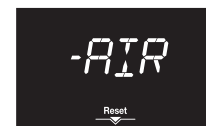

To interrupt the vent cycle press

When the vent cycle is running all heat requests are inhibited except for DHW requests when the boiler is not in OFF.

The cycle can also be interrupted by a DHW request, if the boiler is not OFF.

5.9 MANUAL CALIBRATION PROCEDURE (GAC)

The GAC procedure, which is useful to calibrate the gas valve and combustion control system, is mandatory following: gas conversion - gas valve replacement - board replacement - fan replacement - cleaning of primary heat exchanger and/or burner - replacement of flame detection electrode (ionisation) - replacement of burner insulation panel - modification of suction/exhaust pipes.

The GAC procedure must also be carried out on first start-up. If this procedure is not carried out in the time required, the boiler will still be safe however it may be limited in performance and may also process combustion control signals.



The procedure must be performed with the casing closed.

Any repetition of the GAC that is not successfully completed leaves the system in the “GAC not completed” condition.

The system alternates (except when signalling ALARM, INFO and PROGRAMMING) the normal display with the word GAC and spanner icon as a reminder that the GAC is required and that therefore the boiler may have limitations in its operation.

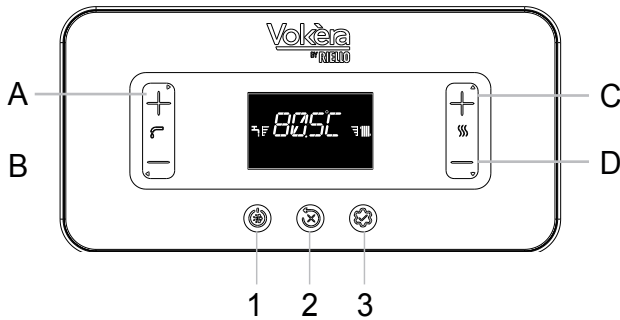

- Power on the boiler electrically and wait for the vent cycle to run (see section 5.8).
- If it is set to OFF, set SUMMER mode with key 1.
- Generate a DHW request with a DHW delivery of 5 litres per minute or more. Although there are no limitations on the part of the system, except those provided for by the ALARMS supervision, it is still advisable to do the GAC with cold domestic water inlet below 15°C or at least with a temperature compatible with the DHW delivery rate.
- Wait until the flame symbol appears on the display.



- Access the parameters (see procedure indicated in “6.1 Setting password, access and parameter modification”).
 - Select menu P2 using keys C or D and confirm using key A.
 - Select parameter P206 using keys C or D and confirm using key A.
- Note: the parameter is not available when there is no heat request.
- Set P206 = 1 using key C to activate the GAC function.



The display shows GAC flashing and a waiting phase of about 1 minute begins, after which calibration begins. During this phase, the word ‘GAC’ blinks, alternating with fan speed, for a duration of approximately 2-5 minutes.

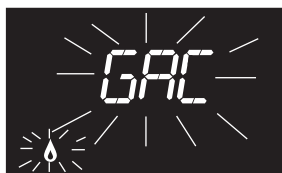

At this stage, no key must be pressed until the word “END” appears, indicating that the procedure has been successfully completed.



At the end of the function, the parameter automatically returns to 0.



If the GAC procedure is not completed, the system allows the execution of a GAC retry which is indicated on the display with “RTY” and then proceeds by pressing the key B.



NOTE: If it is not possible to dissipate heat in the domestic hot water, it is however possible, for high temperature systems, to carry out the GAC on heating request, setting the heating water setpoint at 80.5°C or even better, activating the combustion analysis and subsequently, with flame on, start the GAC.

Once the procedure is finished, press the key B 3 times to return to the main screen. If the procedure is not carried out when it is mandatory to do so, it may lead to a limited operation and the possibility of abnormal combustion control signals occurring.

If a fault occurs during the procedure, or if the heat request is interrupted, the procedure would be prematurely terminated by displaying the fault status or automatically returning to the main screen. In this case, the procedure must be repeated.

5.10 SETTING THE THERMOREGULATION

Thermoregulation is only available with an outdoor temperature sensor connected and is only active for the HEATING function.

THERMOREGULATION is enabled in the following way:

- access the parameter P4 → P418 = 1.

With P418 = 0 or the outdoor temperature sensor disconnected, the boiler **works at a fixed setpoint**.

The temperature value measured by the outdoor temperature sensor is displayed in section 6.4 at I009.

The thermoregulation algorithm will not use the measured outdoor temperature value directly, but rather a weighted outdoor temperature value, which takes account of the insulation of the building: in well-insulated buildings, external temperature variations have less influence on the room temperature than in less insulated buildings.

This value can be displayed in the INFO menu at I010.

REQUEST FROM OT CHRONOTHERMOSTAT

In this case, the delivery setpoint is calculated by the timed thermostat on the basis of the outdoor temperature value, and by the difference between the real ambient temperature and the required ambient temperature.

REQUEST FROM ROOM THERMOSTAT

In this case, the delivery setpoint is calculated by the adjustment board on the basis of the outdoor temperature value, to obtain an estimated ambient temperature of 20° (reference ambient temperature). There are 2 parameters that are used to calculate the delivery setpoint:

- slope of the compensation curve (KT) - modifiable by technical personnel
- offset to reference ambient temperature - can be modified by the user.

TYPE OF BUILDING (parameter P433)

It is indicative of the frequency with which the value of the calculated outdoor temperature for thermoregulation is updated, a low value for this value will be used for buildings that have little insulation.

REACTIVITY SEXT (parameter P434)

It is an indication of the speed with which variations of the measured outdoor temperature affect the calculated outdoor temperature value for thermoregulation, low values indicate high speeds.

Choice of thermoregulation curve (parameter P419)

The heating thermoregulation curve maintains a theoretical temperature of 20°C in the room for outdoor temperatures between +20°C and -20°C. The choice of the curve depends on the minimum design outdoor temperature (and thus the geographical location) and the design flow temperature (and thereby the type of system) and should be carefully calculated by the installer, according to the following formula:

KT = Project delivery T. - Tshift
 20- min. outdoor project T.

Tshift = 30°C standard system
 25°C floor installations

If the calculation gives an intermediate value between two bends, you are advised to choose the thermoregulation bend closest to the value obtained.

Example: if the value obtained from the calculation is 1.3, it lies between curve 1 and curve 1.5. Choose the nearest curve, i.e. 1.5. The settable KT values are as follows:

- standard system: 1,0÷3,0
- free-standing system 0,2÷0,8.

With parameter P419 set the chosen thermoregulation curve:

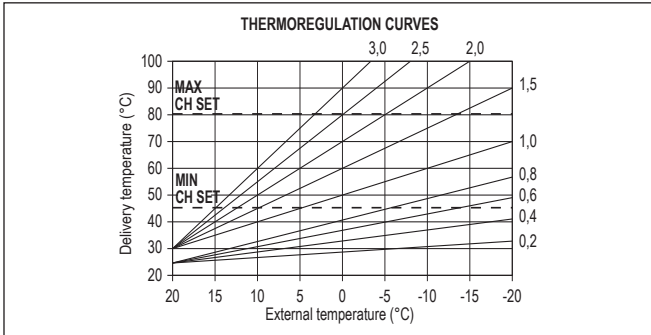

Offset on the reference ambient temperature

In any case, the user can indirectly modify the HEATING setpoint value by inserting an offset on the reference temperature (20°C). This offset may vary from -5 to +5 (offset 0 = 20°C). To correct the offset, refer to section 8.4.

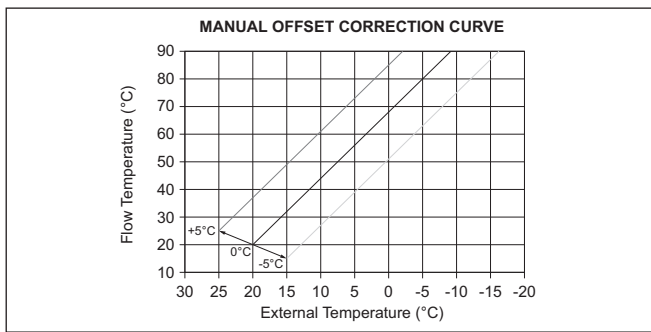

NIGHT COMPENSATION (parameter P420)

If a time programmer is connected to the input ROOM THERMOSTAT, from the parameter P420 night compensation can be enabled.

- set parameter P420 = 1.

In this case, when the CONTACT is CLOSED, the heat request is made by the flow probe on the basis of the outdoor temperature, to obtain a nominal ambient DAY temperature (20°C). The OPENING OF THE CONTACT does not produce a switch-off, but rather a reduction (parallel shift) of the climatic NIGHT curve (16°C).

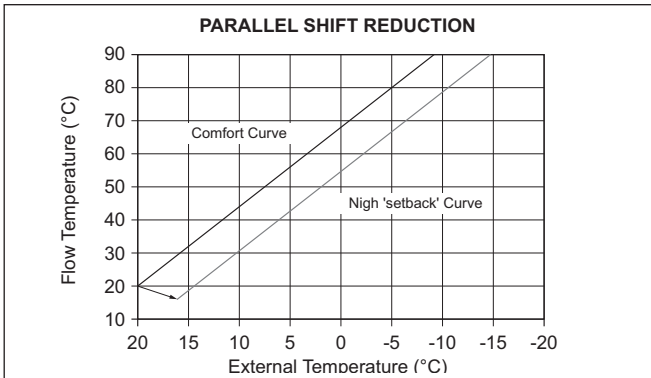

In this case too, the user can indirectly modify the HEATING setpoint value by inserting an offset on the reference DAY temperature (20°C) or NIGHT temperature (16°C). This offset may vary from [-5 to +5]. NIGHT COMPENSATION is not available if OT+ chrono is connected. To correct the offset, refer to section 8.3.

5.11 "DHW COMFORT" FUNCTION

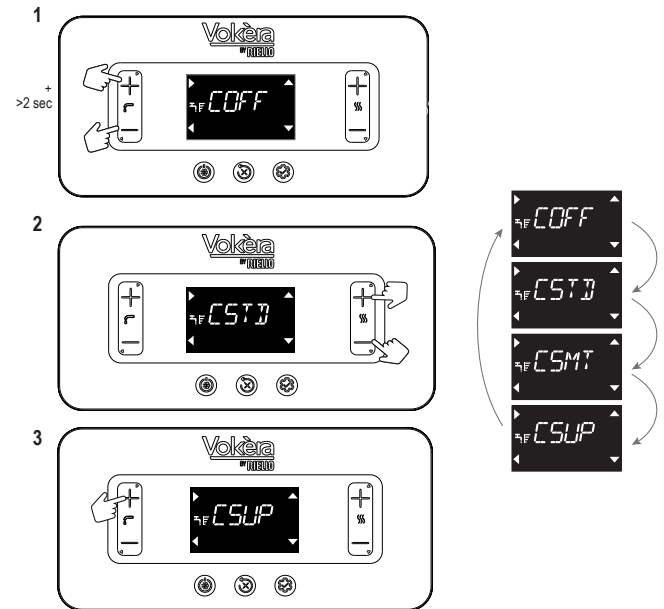

Function	Scrolling message
COFF	COMFORT OFF
CSTD	COMFORT STANDARD
CSMT	COMFORT SMART
CSUP	COMFORT SUPERIOR

CSTD (PREHEATING function)

Setting CSTD activates the boiler pre-heating function. This function keeps the water in the domestic hot water exchanger hot, to reduce standby times when a request is made. When the preheating function is enabled, a scrolling message COMFORT STANDARD appears on the display. To deactivate the preheating function, set COFF.

The function is not active when the boiler is OFF.

CSMT (TOUCH & GO function)

If you do not want PRE-HEATING to be always active and you want hot water immediately ready, it is possible to preheat the domestic hot water just a few moments before taking it. Set CSMT to activate the Touch&Go function. This function allows you, by opening and closing the tap, to start the instantaneous pre-heating that prepare the hot water only for that water take. When the Touch&Go function is enabled, a scrolling message COMFORT SMART appears on the display.

CSUP (SMART preheating function)

When this function is active, the 3-way valve on DHW enables post-circulation at the end of the heating request until one of the following conditions is met:

- DT (flow sensor - return) < 2 °C
- Post-circulation duration > 20 sec
- Return temperature > 65 °C.

5.12 SPECIAL DHW FUNCTIONS

Parameter P511 allows special functions to be activated during the DHW modulation phase. These functions improve the performance of the boiler in particularly difficult operating conditions (e.g. particularly high inlet water temperatures, very low flow rates, use in combination with solar storage cylinders).

0	No special function active (default value)
1	Introduction of flow switch/flowmeter start delay (parameter P510 - SERVICE)
2	In the event of a shut-down due to overheating in the DHW area (with withdrawal in progress) the fan is kept at idle to reduce the waiting time for restarting
3	Absolute DHW thermostats
4	Anti-slope smart DHW function
5	All four previous functions active

DHW DELAY function (1)

This function enables a delay, equal to the value set in the parameter P510, for activating the pump and fan when a DHW request arrives.

SMART FAN function (2)

When this function is active, the fan is kept at the minimum (MIN) and is not disabled if the burner is switched off due to DHW over-temperature (with the request still active).

ABSOLUTE THERMOSTATS function (3)

When this function is active, the DHW thermostats for burner ON/OFF switch from the relative value to the absolute one.

ANTI-PENDULATION function (4)

When this function is active, the boiler automatically switches to ABSOLUTE THERMOSTATS mode if the burner is switched off due to DHW overtemperature (with extraction in progress); when the burner is OFF, the fan is kept at the minimum. The thermostats go back to being "CORRELATED" when extraction ends.

5.13 SCREED HEATER FUNCTION

For a low temperature system, the boiler has a "screed heater" function that can be activated in the following way:

- set the boiler to OFF by pressing the button  (function only available in this operating state)

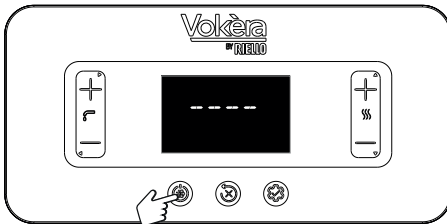

- access technical parameters → P4 → P409 = 1 → confirm; the display shows:

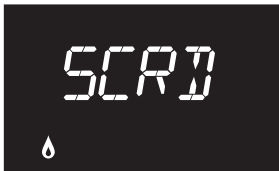

The screed heater function lasts 168 hours (7 days) during which, in the zones configured as low temperature, a heating request is simulated with an initial zone outlet of 20°C, then increased in line with the table below.

By accessing the INFO menu from the main screen of the interface, it is possible to display the value of I001, relating to the number of hours elapsed since the function was activated. Once activated, the function takes priority, if the machine is shut down by disconnecting the power supply, when it is restarted the function picks up from where it was interrupted. The function can be interrupted before its end by switching the boiler to a state other than OFF or by selecting P409= 0 from the menu P4.

DAY	TIME	TEMPERATURE
1	0	20°C
	6	22°C
	12	24°C
2	18	26°C
	0	28°C
3	12	30°C
	0	32°C
4	0	35°C
5	0	35°C
6	0	30°C
7	0	25°C

Note: The temperature and increase values can be set to different values only by qualified personnel, only if strictly necessary. The manufacturer declines all responsibility if the parameters are incorrectly set.

In the INFO menu, line I001 displays the number of hours elapsed since the activation of the function.

5.14 CHECKS DURING AND AFTER THE INITIAL START-UP

After starting up, check that the boiler carries out the start-up procedures and subsequent shut-down properly.

- Check the domestic hot water operation by opening a hot water tap in SUMMER mode or WINTER mode.
- Check the full stop of the boiler by turning off the system's main switch.

- After a couple of minutes of continuous operation to be obtained by turning the system's main switch to "on", setting the boiler mode selector to Summer and by keeping open the domestic hot water device, the binders and manufacturing waste evaporate; only subsequently it will be possible to control combustion.



5.15 COMBUSTION CHECK

- The checks of the settings of CO₂ in relation to the reference parameters, indicated in the tables below, must be carried out with the casing closed.

To carry out the combustion analysis, proceed as follows:

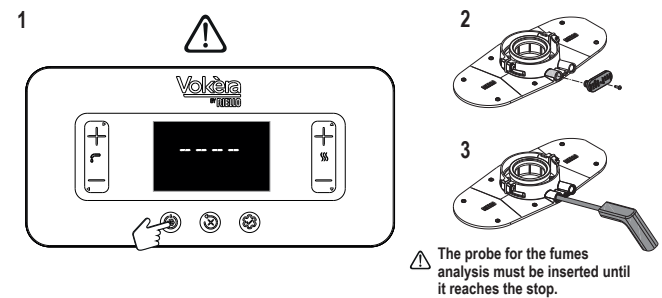

The probe for the fumes analysis must be inserted until it reaches the stop.

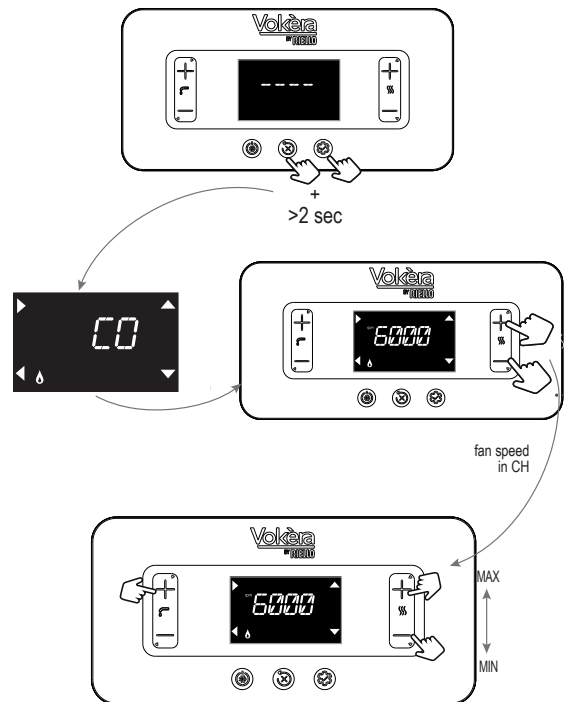

- The display will show the defined rpm for 10 sec, along with the rpm icon.
- By setting the maximum value, the boiler will operate at maximum output; by setting the minimum value, the boiler will operate at minimum output.



- Check on the analyser that the values of CO₂ max e min comply with the following tables.

CO ₂ * max		METHANE GAS (G20)	LIQUID GAS (G31)	
	25C	8,8	10,0	%
	30C	8,8	9,9	%
	35C	8,8	9,9	%
(*) CO ₂ tolerance = ±1%				

CO ₂ * min		METHANE GAS (G20)	LIQUID GAS (G31)	
	25C	8,8	10,0	%
	30C	8,8	10,0	%
	35C	8,8	10,0	%
(*) CO ₂ tolerance = ±1%				

- Check that the values of O₂ (max, nominal and min) related to 20% hydrogen mixture are in accordance with the following.

O ₂ value relative to the 20% hydrogen mixture	Qmax	max	%	25C	30C	35C
		nominal	%	4,3	4,3	4,3
		min	%	6,2	6,2	6,2
	Qmin	max	%	2,4	2,4	2,4
		nominal	%	4,3	4,3	4,3
		min	%	6,2	6,2	6,2

- The COMBUSTION ANALYSIS lasts a maximum of 15 minutes; you can in any case terminate the procedure prematurely by pressing **B**.
- If the system is in low temperature, live, without mixing or thermostatic valves, the COMBUSTION ANALYSIS must be carried out in DHW request mode.

- !** COMBUSTION ANALYSIS is terminated prematurely if:
 - the delivery temperature exceeds 95°C; it will ignite again when the temperature falls below 75°C
 - a flame is not detected resulting in an alarm
 - in the event of an alarm.

- !** With the OT+ device connected, the combustion control function cannot be activated. To carry out the flue gases analysis, set the value for parameter P803 to 0. Remember to reset the parameter value to reactivate the OT+ connection at the end of the flue gases analysis.

When the check has ended:

- exit function by pressing the key **B**
- remove the analyser probe and close the combustion analysis outlet with the relative plugs and screw
- put the analysis probe adapter (supplied with the boiler) in the documentation bag
- set the boiler to the required operating mode, depending on the season
- regulate the requested temperature values according to needs.

5.16 ADJUSTMENTS

The boiler has already been adjusted during manufacturing by the manufacturer. However, if it is necessary to carry out the adjustments again (for example after extraordinary maintenance, after replacing the gas valve, after a gas transformation or after replacing the board) follow the procedures described below.

Maximum and minimum power and maximum heating adjustments must be carried out only by qualified personnel:

P306	minimum fan speed
P307	maximum fan speed
P309	maximum fan speed - heating

- power the boiler
- access technical parameters → **P3** → confirm → select the relevant parameter → confirm
- set the desired values with the keys **C** and/or **D**, referring to the following tables
- check that P309= P310.

- !** The maximum heating fan speed used will be that set in parameter P310.

MAXIMUM NO. FAN ROTATIONS	METHANE GAS (G20)	LIQUID GAS (G31)	
25C	6.300 - 7.900	6.100 - 7.600	rpm
30C	6.200 - 7.400	5.800 - 7.100	rpm
35C	7.400 - 8.600	7.100 - 8.200	rpm

MINIMUM NO. FAN ROTATIONS	METHANE GAS (G20)	LIQUID GAS (G31)	
25C	1.200	1.250	rpm
30C	1.200	1.250	rpm
35C	1.300	1.250	rpm

5.17 GAS CONVERSION

The boiler is designed to operate with methane gas (G20) according to the product label. It is possible to convert the boiler to LPG (G31) via the parameter P201.

- !** Conversion from a family gas to other family gas can be performed easily also when the boiler is installed.

- !** This operation must be carried out by professionally qualified personnel.

- Access the technical parameters → **P2** → P201 → confirm.

- Use key **C** or **D** to select the desired option:

P201 = 1 (NG)

P201 = 2 (LPG)

P201 = 3

P201 = 4

- !** Confirm the parameter change with **ENTER**, then switch off the power supply to the boiler.

Once the GAS parameter has been modified, a new "GAC" procedure must be carried out (see section 5.9). Check that the fan revolutions correspond to what is indicated in tables 1 and 2, section 5.16.

5.18 OUTPUT CHANGE (P208)

By adjusting parameter P208, the boiler power type can be changed (range 0 ÷ 1, default 0). In particular:

- access the technical parameters → **P2** → P208 →:

25kW: 0 → confirm

35kW: 1 → confirm.

Configure the fan speeds of your boiler as indicated in tables 1 and 2, section 5.16.

30kW MODEL

- Access the technical parameters → **P2** → P208 → 1 (35kW) → confirm.

- Change the fan speed as indicated in tables 1 and 2 of your model.



- !** Disconnect and reconnect power to the boiler after changing the parameters.

5.19 SIGNALLING AND FAULTS

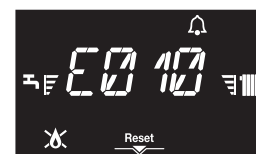
If a fault is present, the icon  blinks at a frequency of 0.5sec ON and 0.5sec OFF, the backlight blinks for 1min at a frequency of 1sec ON and 1sec OFF, after which it switches off, while the bell continues to flash. The error code appears on the 4 digits of the display.



When a fault occurs, the following icons may appear:

-  lights up for a flame alarm (E010)
- RESET lights up for an alarm that needs to be manually reset by the user (e.g. a flame lockout)
-  lights up along with the  icon, apart from flame lockout and water failure faults

- lights up in the presence of water pressure alarms or warnings, in which case the water pressure value is displayed as an alternative to the fault code every 3 seconds.

Reset function

To restore boiler operation in the event of a fault, the boiler must be operated by pressing the RESET button.

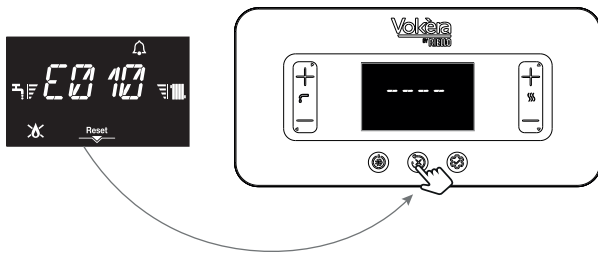

At this point, if the correct operating conditions have been restored, the boiler will restart automatically. Up to a maximum of 5 consecutive attempts to unlock the same alarm from the interface are possible, after which the error code E099 appears on the display.



In this case, the boiler must be disconnected from the electricity supply and then reconnected again, to reactivate operation.

⚠ If the reset attempts do not activate the boiler, contact the Technical Assistance Centre.

Fault E041

Should the pressure value fall below the safety value of 0.3 bar, the boiler displays the fault code E041 for a transitory time of 10 min.

When the transitional time has finished, if the fault persists the fault code E040 is displayed.

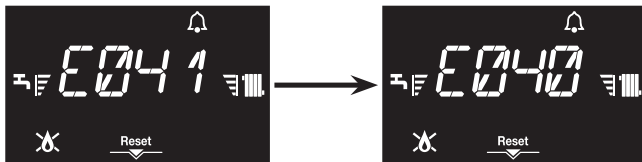

With a boiler in fault E040:

- attach the temporary flexi-pipe and open both filling taps **A&B**
- check that the pressure value reaches 1-1.5 bar by means of a hydrometer located under the shelf or by accessing the INFO menu (section 6.4, item I018)
- close both **A&B** taps and remove the flexi-pipe.

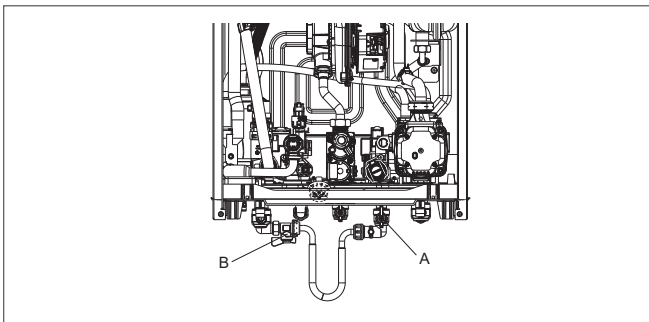

Press **X** to restore operation.

Once operation is restored, the boiler performs an automatic vent cycle as described in Section 5.

⚠ If the drop in pressure is very frequent, request the intervention of the Technical Assistance Centre.

Fault E060

The boiler is working normally, but does not guarantee the stability of the DHW temperature that is, however, supplied at a temperature of around 50°C. Intervention of the Technical Assistance Centre is required.

Fault E091

The boiler has an auto-diagnostic system which, based on the total number of hours in certain operating conditions, can signal the need to clean the primary exchanger (alarm code E091). Once the cleaning operation has been completed, reset to zero the total hour meter with special kit supplied as an accessory following procedure indicated below:

- access the technical parameters → **P3** → P312 → P312 = 1 → confirm.

NOTE: The meter resetting procedure should be carried out after each in-depth cleaning of the primary heat exchanger or if it is replaced.

The fault E091 occurs when the hour counter exceeds 2500 hours; this value can be verified as follows:

- access the INFO menu → I015 to display the value of the flue gas probe hour counter (display/100, example 2500h = 25).

5.20 REPLACING THE GAS VALVE (P205)

After replacing the gas valve it is necessary to reset the value **P1** (see photo) as follows:



- set the boiler to OFF
- access the parameters setting the password in accordance with section 6.1
- using keys **C** or **D** access the parameter **P2** → P205 and confirm using the key **A**
- using keys **C** or **D** enter the second and third digits of the **P1** value (i. e. 034 becomes 34) written on the gas valve in the boiler (each gas valve has its own offset P1 value), confirm with key **3**
- disconnect the boiler from the power supply for at least 10 seconds; then reconnect to the mains power supply.

Once the replacement is complete, a new "GAC" procedure must be carried out (see section 5.9).

⚠ If the gas valve is replaced, also replace the relative sealing gaskets.

To tighten the gas valve ramp nut, apply a torque equal to 25 Nm, limiting the rotation of the valve.

5.21 REPLACING THE INTERFACE

System configuration operations must be carried out by professionally qualified personnel of the Technical Assistance Centre.

If the interface card is replaced, the user may be asked to reset the time and day of the week values at power on (see section 8); also check and reset, if necessary, information on hourly heating and DHW programming (see section 8.1) and the Feeder Bottle function (see section 8.12); note that no reprogramming of the configuration parameters is necessary, the value of which is retrieved from the regulation and control board in the boiler. Instead, it may be necessary to reset the DHW and/or heating setpoint values.

5.22 BOARD REPLACEMENT

If case of the control board is replacement and adjustment procedure, it may be necessary to check the configuration parameters and possibly reconfigure them. Consult the parameter table to identify the board default values, the factory set values and the customized ones.

The parameters to necessarily be checked and possibly reset are: P201 • P205 (with boiler in OFF) • P208 • P301 • P302 (SERVICE) • P306 • P307 • P309 • P310.

Disconnect the boiler from the power supply for at least 10 seconds; then reconnect to the mains power supply.

Once the replacement is complete, perform a new "GAC" procedure must be carried out (see section 5.9).

ERROR CODE	ERROR MESSAGE	ALARM DESCRIPTION	
E010	Flame lockout	DEFINITIVE	
E011	Parasitic flame		
E012	Maximum number of flame losses		
E013	Hardware test failed		
E014	Flame detect test failed		
E015	Voltage detect flame test failed		
E020	Limit thermostat		
E021	Gas valve control malfunctioning		
E030	Fan error		
E031	Fan failure mechanical blockage		
E032	Rotor fan failure blocked		
E033	Rotor fan failure damaged		
E034	Chimney obstruction in prevention		
E035	Blockage obstruction flue gas low power		
E036	Blockage obstruction flue gas high power		
E037	Failed combustion check low power		
E038	Combustion check failed check high power		
E039	Abnormal flame value		
E040 + bar value	Water pressure low... Fill the system		
E042	Water transducer - LWCO error		
E075	Valve opening limit reached		
E092	Calibration FAILED		
E088	CAC failed		
E093	Too many calibration attempts		
E094	Lambda over limit		
E097	Check failed		
E098	GAC failed		
E099	Reset attempts exhausted		
E041 + bar value	Fill the system		TRANSITORY
E050	Smoke obstruction error low power		
E051	Smoke obstruction error high power		
E052	Hardware error out of threshold		
E055	No card fan communication		
E056	No communication microprocessor card		
E060	DHW probe error		
E070	CH probe error		
E071	CH probe overtemp		
E072	Return - Flow differential		
E077	Water thermostat main zone		
E080	Return probe error		
E081	Return probe overtemp		
E082	Flow - Return differential		
E090	Exhaust probe error		
E091	Clean primary ht exchanger		
E095	Calibration failed		
E096	Lambda over limit		
FIL + bar value	Low pressure check the htg system		
 flashing + bar value	High pressure check the htg system	SIGNAL	
COM	Appliance PCB communication lost (more than 30 seconds)	SIGNAL: (the boiler continues to operate but with no display or keys)	
E065	IMOD error	SIGNAL	
FWER	Warning firmware versions not compatible	SIGNAL: (the boiler continues to operate but with no display or keys)	
CFS	Call for Service	SIGNAL	
SFS	Stop for Service	DEFINITIVE	
OBCD	On board clock damaged	SIGNAL: (the boiler continues to operate but with no display or keys)	

6. MAINTENANCE AND CLEANING



Periodic maintenance is essential to the safety, efficiency and duration of the boiler. It allows for the reduction of consumption, polluting emissions and keeping the product safe and reliable over time. Before starting maintenance operations:

- turn off the fuel and water taps of the heating and domestic hot water system.

To ensure product characteristics and efficiency remain intact and to comply with current regulations, it is necessary to render the appliance to systematic checks at regular intervals.

This normally means the following tasks: 

- removing any oxidation from the burner
- removing any scale from the heat exchangers
- check the state of deterioration of the electrodes and, if they have deteriorated, replace them together with their seals
- check and general cleaning of exhaust and intake pipes
- checking the external appearance of the boiler
- checking the ignition, switch-off and operation of the appliance, in both DHW mode and heating mode

- checking the seal on the couplings and the gas/water/condensate connection pipes
 - checking gas consumption at maximum and minimum output
 - if the DHW pressure is less than 3 bar, empty the boiler's DHW circuit and check that the heating circuit pressure is maintained
 - checking the integrity of the insulation of electrical cables, particularly in the vicinity of the primary heat exchanger
 - checking the gas failure safety device
 - checking and cleaning the siphon
 - checking the cleanliness of the fan, internal extraction (including the air filter when provided)
 - **checking there is water in the drain-trap; if not, fill it.**
-  The electronic board and the gas valve do not require a specific check aimed at evaluating aging and deterioration.
-  When servicing the boiler, the use of protective clothing is recommended in order to avoid personal injury.

⚠ After maintenance work has been carried out, an analysis of the combustion products must be carried out to check that they are functioning properly.

⚠ Do not clean the appliance or its parts with inflammable substances (e.g. petrol, alcohol, etc.).

⚠ Do not clean panels, painted parts and plastic parts with paint thinner.

⚠ Panel cleaning must be carried out only with soapy water.

Cleaning the primary heat exchanger

- Switch off the electrical supply by turning the main system switch OFF.
- Close the gas shut-off valve.
- Remove the casing as explained in section 4.5.
- Disconnect the connection cable of the ignition and detection electrodes.
- Disconnect the power cables of the fan.
- Remove the clip securing the gas train from the mixer.
- Loosen the gas train nut.
- Extract the gas train from the mixer and rotate it.
- Remove the 4 nuts that secure the combustion unit.
- Remove the air/gas conveyor assembly including fan and mixer, taking care not to damage the insulation panel and electrode.
- Remove the siphon connecting pipe from the condensate drain fitting of the heat exchanger and connect a temporary collecting pipe. At this point proceed with the heat exchanger cleaning operations.
- Vacuum out any dirt residue inside the heat exchanger, taking care NOT to damage the retarder insulating panel.
- Clean the coils of the heat exchanger with a soft bristled brush.

⚠ DO NOT USE METAL BRUSHES THAT COULD DAMAGE THE COMPONENTS.

- Clean the spaces between the coils using a 0.4 mm thick blade or similar.
- Vacuum away any residue produced by the cleaning intervention.
- Rinse with water, taking care NOT to damage the retarder insulating panel.

⚠ If there are stubborn fuel gas deposits on the heat exchanger surface, remove them by spraying with natural white vinegar, taking care NOT to damage the retarder insulating panel.

- Leave it to work for a few minutes.
- Clean the coils of the heat exchanger with a soft bristled brush.

⚠ DO NOT USE METAL BRUSHES THAT COULD DAMAGE THE COMPONENTS.

- Rinse with water, taking care NOT to damage the retarder insulating panel.
- Make sure the retarder insulation panel is undamaged and replace it if necessary following the relative procedure.
- After cleaning, carefully assemble the components again repeating the indications provided above but in the reverse order.
- To tighten the fastening nuts of the air/gas conveyor assembly, use a tightening torque of 6 Nm, following the sequence indicated on the die-cast (1,2,3,4).
- Turn the power and gas feeding to the boiler back on.

⚠ It is necessary to carry out a new "GAR" procedure followed by the "GAC" procedure (see section 5.9).

⚠ What is indicated is also valid in the case of replacement of the conveyor alone, the exchanger or the conveyor and exchanger assembly.

Cleaning the burner

- Switch off the electrical supply by turning the main system switch OFF.
- Close the gas shut-off valve.
- Remove the casing as explained in section 4.5.
- Disconnect the connection cable of the ignition and detection electrodes.
- Disconnect the power cables of the fan.
- Remove the clip securing the gas train from the mixer.
- Loosen the gas train nut.
- Extract the gas train from the mixer and rotate it.
- Remove the 4 nuts that secure the combustion unit.

- Remove the air/gas conveyor assembly including the fan and mixer, taking care not to damage the insulating ceramic panel and the electrodes. At this point proceed with the burner cleaning operations.
- Clean the burner with a soft bristle brush, taking care not to damage the insulation panel and electrodes.

⚠ DO NOT USE METAL BRUSHES THAT COULD DAMAGE THE COMPONENTS.

- Check that the burner insulating panel and the sealing gasket are undamaged and replace them if necessary, following the relative procedure.
- After cleaning, carefully assemble the components again repeating the indications provided above but in the reverse order.
- To close the fixing nuts of the air/gas conveyor assembly, use a tightening torque of 6 Nm.
- Turn the power and gas feeding to the boiler back on.

⚠ Carry out an analysis of the combustion products. Only if it returns values outside of tolerance, it is necessary to repeat a new "GAR" procedure followed by the "GAC" procedure (see section 5.9).

⚠ What is indicated is also valid in the case of replacement of the conveyor alone, the exchanger or the conveyor and exchanger assembly.

Replacing the burner insulating panel

- Loosen the screws holding the ignition/detection electrode, and remove it.
- Remove the burner insulating panel by inserting a blade just under the surface.
- Remove any residual fixing adhesive.
- Fit the new burner insulating panel.
- The new insulating panel does not need to be fixed with an adhesive as its geometric form ensures perfect coupling with the heat exchanger flange.
- Refit the ignition and detection electrodes using the screws previously removed and replacing the relevant seal. To tighten the screws, apply a torque of 2.3 Nm.

⚠ Do not perform GAR and/or GAC.

Siphon check and cleaning

- Disconnect the pipes (A - B), remove the clip (C) and remove the drain-trap.
- Clean the parts of the drain-trap to remove any solid residue.

⚠ Carefully reposition the previously removed components.

⚠ At the end of the cleaning sequence, fill the drain-trap with water (see section 5.7) before re-starting the boiler.

⚠ Do not perform GAR and/or GAC.

⚠ What is indicated also applies in the case of replacing the siphon.

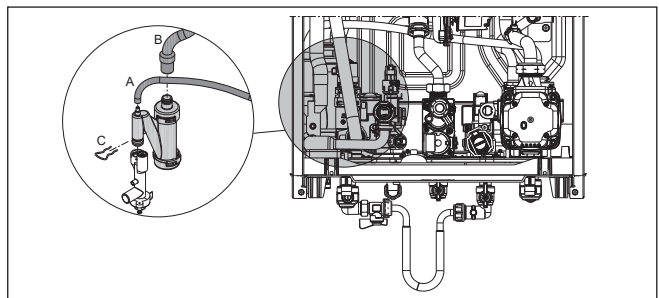

Ignition and detection electrodes

The ignition and detection/ionization sensor electrodes perform an important function in the boiler ignition phase and in maintaining correct combustion; in this regard, during annual maintenance, it is necessary to always check that they are correctly positioned and that the reference dimensions indicated in the figure are strictly respected.

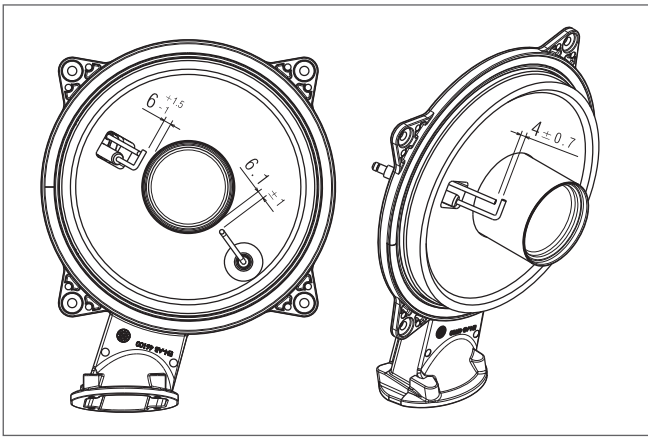

⊖ Do not sand the electrodes. If the electrodes need to be cleaned, dust them using a soft bristle brush.

⚠ In the event of deformation and deterioration of the electrodes outside the tolerances, replace them.

To tighten the screws, apply a torque of 2.3 Nm.

⚠ In order to prevent potential operating anomalies, the ignition and detection/ionisation sensor electrodes must be replaced every 5 years.

⚠ It is necessary to carry out a new "GAR" procedure followed by the "GAC" procedure (see section 5.9).

Board replacement

▪ The control and regulation board does not provide a specific procedure for verifying its deterioration. In case of replacement, refer to section 5.22.

Interface board replacement

▪ The interface board does not provide a specific procedure for verifying its deterioration. In case of replacement, refer to section 5.21.

Gas valve replacement

▪ The gas valve does not provide a specific procedure for checking its deterioration. In case of replacement, refer to section 5.20.

▪ The gas valve does not provide a specific cleaning procedure.

6.1 SETTING PASSWORD, ACCESS AND PARAMETER MODIFICATION

Key pressure = light: value progress of one unit at a time; prolonged: fast forward

In the manual, whenever necessary:

- enter the password to access the parameters
- choose, modify and/or confirm parameters.

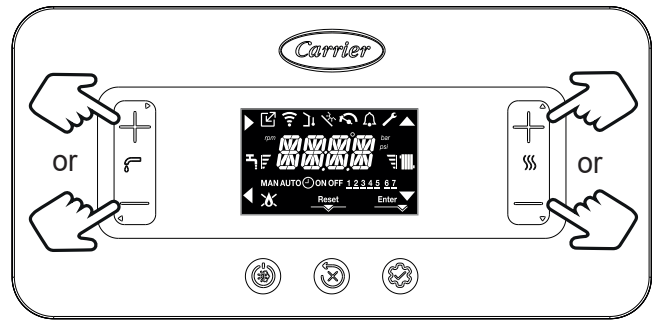

Actions	
password entry	points 1 - 7
parameter choice	points 8-10
modify and confirm parameter	points 11-12a
exit without saving	point 12b
return to the main screen	point 13

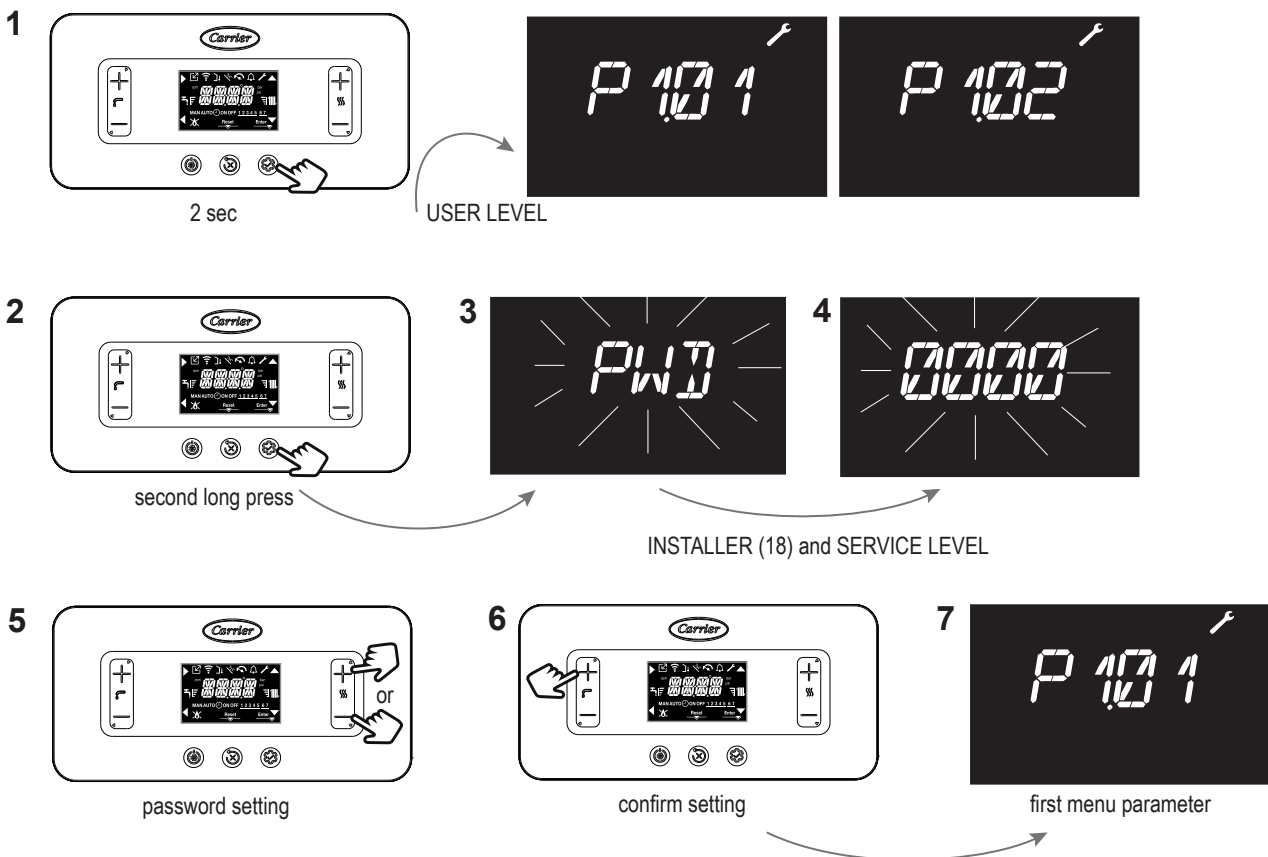

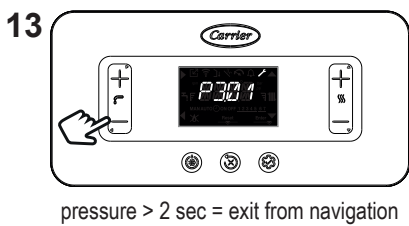
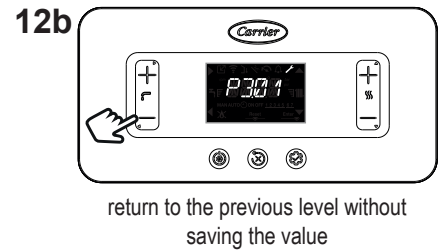
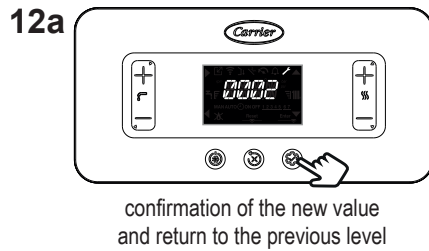
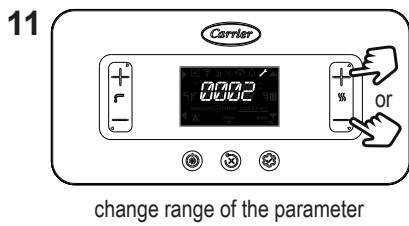
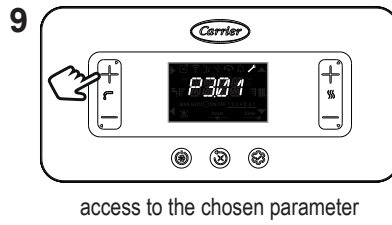
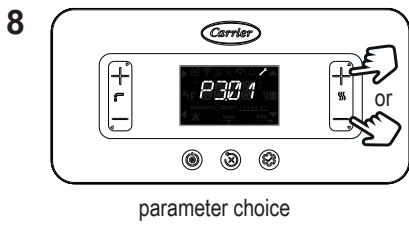

If the buttons are not pressed, after 60 seconds the interface will automatically reposition itself on the main screen.

6.2 PROGRAMMABLE PARAMETERS

The following table lists the programmable parameters; USER (always available) and INSTALLER (access with psw 18): set the password following the procedure indicated in section 6.1. For a detailed explanation of the parameters, please refer to section 6.3.

Some of the information might not be available depending on the access level, machine status or system configuration.

		WHICH PARAMETERS ARE VISIBLE/ACCESSIBLE		
		USER	INSTALLER	SERVICE
LEVEL PASSWORD	USER (always available)	X		
	INSTALLER (psw 18)	X	X	
	SERVICE	X	X	X

USER PARAMETERS		Value		Password level	Factory setting	Customised values
		Min	Max			
P1	SETTINGS					
	P101	LANGUAGES	0 0: IT • 1: RO • 2: FR • 3: EN • 4: SR • 5: HR • 6: ES • 7: GR • 8: BG • 9: PL • 10: SL	10	USER	0
	P102	TIME			USER	
	P103	TIME PROGRAM			USER	
	P104	UNIT OF MEASURE	0 (metric)	1 (imperial)	USER	0
	P105	SCROLLING	0 (disabled)	1 (enabled)	USER	0
	P106	BUZZER	0	1	USER	1





INSTALLER PARAMETERS			Value		Password level	Factory setting	Customised values	
			Min	Max				
MENU	PARAMETER							
P2	COMBUSTION							
	P201	GAS - GAS TYPE	1	4	INSTALLER	1		
	P205	d52 - P1 GAS VALVE	20	70	INSTALLER if boiler in OFF	45		
	P206	GAC - VALVE CALIBRATION	0	1	INSTALLER only if there is a flame	0		
	P208	APL - POWER	0 (25kW)	1 (35kW)	INSTALLER	0		
P3	CONFIGURATION							
	P301	HYDRAULIC CONFIGURATION	0	4	INSTALLER	2*		
	P306	MIN FAN SPEED	1000 rpm	3600 rpm	INSTALLER	refer to the technical data table		
	P307	MAX FAN SPEED	3700 rpm	10000 rpm	INSTALLER	refer to the technical data table		
	P309	MAX FAN SPEED HTG	P306 (MIN FAN SPEED)	P307 (MAX FAN SPEED)	INSTALLER	refer to the technical data table		
	P310	RANGE RATED	DO NOT CHANGE					
	P311	CONFIG AUX 1	0	2	INSTALLER	0		
	P312	EXHAUST PROBE RESET	0	1	INSTALLER	0		
P4	HEATING							
	P405	PUMP CONTROL TYPE	41	100	INSTALLER	85		
	P408	OT CASCADE CONTROL	NOT USED ON THIS MODEL					
	P409	SCREED FUNCTION	0	1	INSTALLER if boiler in OFF and LT systems	0		
	P410	ANTI CYCLE FUNCTION	0min	30min	INSTALLER	3min		
	P411	RESET CH TIMERS	0	1	INSTALLER	0		
	P415	MAIN ZONE TYPE	0	1	INSTALLER	0		
	P416	MAX CH SET	MIN CH SET	HT: 80°C - LT: 45°C	INSTALLER	HT: 80°C - LT: 45°C		
	P417	MIN CH SET	20°C	MAX CH SET	INSTALLER	HT: 40°C - LT: 20°C		
	P418	WEATHER COMP ENABLE	0	1	INSTALLER if outdoor temperature sensor present	0		
	P419	WEATHER COMP CURVE	HT: 1.0 - LT: 0.2	HT: 3.0 - LT: 0.8	INSTALLER only if P418 = 1	HT 2.0 - LT 0.5		
	P420	NIGHT COMPENSATION	0	1		0		
	P421	CH CLOCK ENABLE	0	1		0		
	P422	MODE SELECTION	0	1		0		
	P433	BUILDING TYPE	5	20	INSTALLER only if P418 = 1	5		
	P434	OUTDOOR REACTIVITY	0	255		20		
		HT = HIGH TEMPERATURE LT = LOW TEMPERATURE						
P5	DHW							
	P508	MIN DHW SET	37°C	49°C	INSTALLER	37°C		
	P509	MAX DHW SET	49°C	60°C	INSTALLER	60°C		
	P511	DHW ENHANCED FUNCTION	0	5	INSTALLER	0		

SERVICE PARAMETERS			Value		Password level	Factory setting	Customised values	
			Min	Max				
MENU	PARAMETER							
P3	CONFIGURATION							
	P302	WATER PRESSURE TRANSDUCER	0	1	SERVICE	1		
	P303	AUTO-FILL ENABLE	0	1	SERVICE	0		
	P304	BEGIN SYSTEM FILLING	NOT AVAILABLE ON THIS MODEL					
	P305	AIR PURGING CYCLE	0	1	SERVICE	1		
P4	HEATING							
	P401	HYST OFF HIGH TEMP	2°C	10°C	SERVICE	5°C		
	P402	HYST ON HIGH TEMP	2°C	10°C	SERVICE	5°C		
	P403	HYST OFF LOW TEMP	2°C	10°C	SERVICE	3°C		
	P404	HYST ON LOW TEMP	2°C	10°C	SERVICE	3°C		
P5	DHW							
	P510	DHW DELAY	0 sec	60 sec	SERVICE	0 sec		
	P512	CH DELAY POST-DHW	0	1	SERVICE	0		
	P513	CH DELAY TIME	1 sec	255 sec	SERVICE	6 sec		
P7	SERVICE							
	P701	ENABLE ALARM LOG	0	1	SERVICE	0 (the value automatically switches to 1 after 2 hours of operation)		
	P706	CALL SERVICE FUNCTION	0	2	SERVICE	2		
	P707	SERVICE EXPIRY	0	255	SERVICE	52		
	P708	HIGH EFFICIENCY ENABLE	0	1	SERVICE	0		
P8	CONNECTIVITY							
	P801	BUS 485 CONFIG	0	2	SERVICE	0		
	P803	OT CONFIG	0	1	SERVICE	1		

6.3 DESCRIPTION OF THE PARAMETERS

Some of the following functions may not be available depending on the type of machine and the access level.

PARAMETER	DESCRIPTION
P1 - SETTINGS	P101 To set the desired language: 0: IT ● 1: RO ● 2: FR ● 3: EN ● 4: SR ● 5: HR ● 6: ES ● 7: GR ● 8: BG ● 9: PL ● 10: SL
	P102 To set TIME AND DAY
	P103 To set the TIME SCHEDULE
	P104 To change the unit of measurement: 0 = unit of measurement METRIC / 1 = unit of measurement IMPERIAL. The digits are expressed in decimal format (one digit) for values between -9°C and +99°C, they are expressed in integer format for values ≤ -10°C and ≥ 100°C, the display in °F (Fahrenheit) will always be expressed in integer format.
	P105 To set the scrolling text: 0 = disabled / 1 = enabled
	P106 To enable/disable sound indicators: 0 = buzzer OFF / 1 = buzzer ON
P2 - COMBUSTION	P201 This parameter identifies the type of gas: 1=METHANE ● 2=LPG ● 3=PL-NG ● 4=PROPANE AIR (G230).
	P208 This parameter is used to set the boiler output: 0=25kW - 1=35kW
	P205 This parameter is used to reset the P1 value of the gas valve
	P206 This parameter is used to calibrate the gas valve and combustion control system
P3 - CONFIGURATION	P301 To set the type of hydraulic configuration of the boiler: 0 = HEATING ONLY - 1 = INSTANTANEOUS FLOW SWITCH - 2 = INSTANTANEOUS FLOW METER - 3 = STORAGE CYLINDER WITH PROBE - 4 = STORAGE CYLINDER WITH THERMOSTAT Factory setting = 2, do not modify. When replacing the circuit board, ensure that this parameter is set to 2
	P302 To set the water pressure transducer type: 0 = water pressure switch - 1 = pressure transducer Factory setting = 1, do not modify. When replacing the circuit board, make sure this parameter is set to 1.
	P303 To enable the 'semi-automatic filling' function when a pressure transducer and a filling solenoid valve are installed in the boiler. Factory setting = 0, do not modify. When replacing the circuit board, make sure this parameter is set to 0.
	P304 It only appears if P303 = 1. NOT AVAILABLE ON THIS MODEL.
	P305 To disable the vent cycle function. Factory setting = 1, set the parameter to 0 to disable the function.
	P306 To vary the minimum fan speed.
	P307 To vary the maximum fan speed.
	P309 To vary the maximum heating fan speed (can be programmed within the range P306 - P307).
	P310 RANGE RATED adjustment. DO NOT CHANGE.
	P311 To configure the operation of an additional relay (only if BE09 board installed (accessory kit)) to bring a phase (230Vac) to a second heating pump (additional pump) or a zone valve. Factory setting = 0 and can be programmed within the range 0 - 2 with the following meaning: P311= 0 - management depends on the wiring configuration of the BE09 board: jumper cut: additional pump - jumper present: zone valve. P311= 1 - zone valve management P311= 2 - additional pump management
P4 - HEATING	P312 Allows the operating hours counter to be reset under certain conditions (see "Signalling and faults" fault E091 for details). Factory setting = 0, set to 1 to reset the flue gas probe hour counter after a cleaning operation of the primary heat exchanger. Once the resetting procedure is complete, the parameter automatically returns to the value 0.
	P401 For high-temperature systems, this parameter allows you to set the hysteresis value used by the control board to calculate the burner shut-off flow temperature: SHUTDOWN TEMPERATURE = HEATING SETPOINT + P401. Factory value = 5°C, can be changed in the range 2 - 10°C.
	P402 For high-temperature systems, this parameter allows you to set the hysteresis value used by the control board to calculate the burner ignition flow temperature: IGNITION TEMPERATURE = HEATING SETPOINT - P402. Factory value = 5°C, can be changed in the range 2 - 10 °C.
	P403 For low-temperature systems, this parameter allows you to set the hysteresis value used by the control board to calculate the burner shut-down flow temperature: SHUTDOWN TEMPERATURE = HEATING SETPOINT+ P403. Factory setting = 3 °C, can be changed in the range 2 °C- 10 °C.
	P404 For low-temperature systems, this parameter allows you to set the hysteresis value used by the control board to calculate the burner ignition flow temperature: IGNITION TEMPERATURE = HEATING SETPOINT - P404. Factory setting = 3 °C, can be changed in the range 2°C- 10 °C.
	P405 Proportional variable speed pump.
	P408 Allows the boiler to be set up for cascade applications via OT+ signal. Not applicable to this boiler model.
	P409 Allows you to activate the seat-warming function (see section "Screed heater function" for more details). Factory setting = 0, with boiler in OFF. Set to 1 to activate the floor heating function on low-temperature heating zones. The parameter automatically returns to the value 0 once the warming function is finished; it can be interrupted prematurely by setting the value to 0.
	P410 Allows you to change the forced heating off timing, which relates to the delay time introduced for the re-ignition of the burner when the burner is switched off due to reaching the heating temperature. Factory setting = 3 minutes and can be set to a value between 0 min and 20 min.
	P411 Allows you to cancel the function HEATING RESET TIMING and REDUCED HEATING MAXIMUM OUTPUT, during which the fan speed is limited between the minimum value and 60% of the set maximum heating power, with an increase of 10% every 15 minutes. Factory setting = 0, set to 1 to reset timings.
	P415 Allows you to specify the type of zone to be heated, choosing from the following options: 0 = HIGH TEMPERATURE (factory setting) ● 1 = LOW TEMPERATURE
	P416 Lets you specify the maximum heating setpoint value that can be set: range 20°C - 80°C, default 80°C for high temperature systems ● range 20°C - 45°C, default 45°C for low temperature systems. Note: The value of P416 cannot be less than P417.
	P417 With this parameter you have the possibility of specifying the minimum settable heating setpoint: range 20°C - 80.5°C, default 40°C for high temperature systems ● range 20°C - 45°C, default 20°C for low temperature systems Note: The value of P417 cannot be greater than P416.
	P418 Enables thermoregulation when an outdoor temperature sensor is connected to the system. Factory setting = 0, the boiler always operates at fixed point. With parameter 1 and the outdoor temperature sensor connected, the boiler works in thermoregulation mode. With the outdoor temperature sensor disconnected, the boiler works at a fixed setpoint. See "Setting the thermoregulation" for more details on this function.
P419 Allows you to set the number of the compensation curve used by the boiler when in temperature control. Factory value = 2.0 for high temperature systems and 0.5 for low temperature systems. The parameter can be programmed in the range 1.0 - 3.0 for high temperature systems, 0.2 - 0.8 for low temperature systems. See "Setting the thermoregulation" for more details on this function.	
P420 Activates the 'night compensation' function. Default value = 0, set to 1 to activate the function. See "Setting the thermoregulation" for further information on this function.	
P421 This parameter enables heating time programming. Time programming not enabled = 0 → When the room thermostat contact is closed, the heat request is always fulfilled without time limitation. Time programming enabled = 1 → When the room thermostat contact is closed, the heat request is enabled according to the set time programming.	
P422 This parameter is used to set the mode for switching from manual to automatic heating operation. Default value = 0: switching from manual to automatic time programming must be done by the user by pressing the buttons C+D. Set to 1 to activate the function: switching from manual to automatic time programming takes place automatically at the first time slot change.	
P433 Frequency with which the outdoor temperature value calculated for temperature control is updated; a low value will be used for buildings that have little insulation.	
P434 Reading interval of the outdoor temperature value read by the probe.	

P5 - DHW	P501-P507	Functions related to the availability of a storage cylinder. NOT AVAILABLE ON THIS MODEL.
	P508	To set the minimum DHW setpoint.
	P509	To set the maximum DHW setpoint.
	P510	Only visible when parameter P511= 2 or 5. A delay in seconds is introduced on the activation of the pump and fan when there is a DHW heat request.
	P511	Enable special DHW functions: 0 = no function - 1 = introduction of flow switch/flowmeter start delay - 2 = in case of OFF due to overtemperature in DHW (with withdrawal in progress) the fan is kept at minimum speed to reduce the standby time for restart - 3 = absolute DHW thermostats - 4 = anti-slope smart DHW function - 5 = all previous functions active
	P512	Through this value you can enable/disable the DHW post-circulation function with heating start inhibition.
P513	This value can be used to set the duration of DHW post-circulation when the DHW post-circulation function with heating start inhibition is enabled.	
P7 - SERVICE	P701	To activate the storage of an alarm history. Default 0; the value automatically changes to 1 after 2 hours of operation. Setting the parameter to the value 0 resets the alarm history I039...I043.
	P706	This parameter allows the boiler to be periodically checked according to a preset operating period in parameter P707. There are three possible settings: 0 = function disabled 1 = function enabled with the following rule: if P707 < 4 the display shows the CFS signal if P707 = 0, the display shows the SFS signal (STOP FOR SERVICE) indicating the permanent inhibition of all heating and DHW heat requests. Not resettable 2 = function enabled: when P707 = 0, the display shows the CFS signal without any operating stop In this condition, in the INFO menu (line I044), the number of days elapsed since the CFS warning appeared is displayed (P707 = 0)  The CFS signal occurs at 10 min intervals for a duration of 1 min, 1 month before the end of the period set in parameter P707.
	P707	Preset operating period for service call (parameter P706)
	P708	Automatic function which is activated at first power on or after 60 days of non-use (electrically powered boiler). In this mode the boiler limits the output for 60 minutes in heating mode to a minimum and the maximum temperature in DHW mode to 55°C. Activating the chimney sweep function temporarily disables this function. During execution, the water pressure icon flashes (0.5 sec on - 0.5 sec off). 0 = FACTORY VALUE, disable high efficiency mode • 1 = enable high efficiency mode
P8 - CONNECTIVITY	P801	This parameter is used to enable remote management of the boiler. Three values are available: 0 = FACTORY VALUE. Management from boiler interface and APP if WiFi dongle present (WIFI icon on ) 1 = Management ONLY from boiler interface. 2 = Management from boiler interface and system manager (T300).
	P803	This parameter enables remote boiler management via an OpenTherm device: 0 = OT+ functionality disabled, it is not possible to remotely control the boiler using an OTBus device. By setting this parameter to 0, any OTBus connection is instantaneously interrupted. The icon  and OTB on the display are switched off 1 = FACTORY VALUE. OT+ functionality enabled, an OTBus device can be connected for remote control of the boiler. When connecting an OTBus device to the boiler, the message 'OTB' appears on the display and the icon lights up  .

6.4 INFO MENU

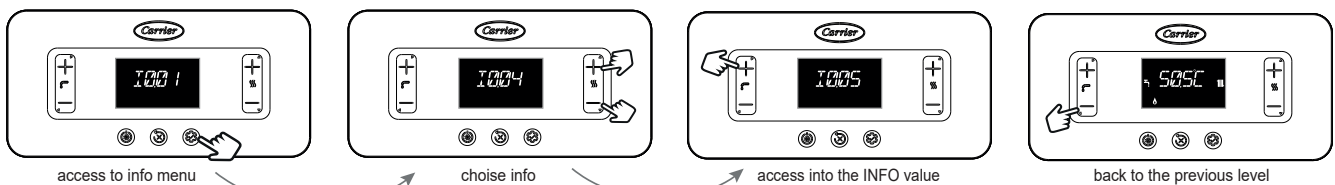







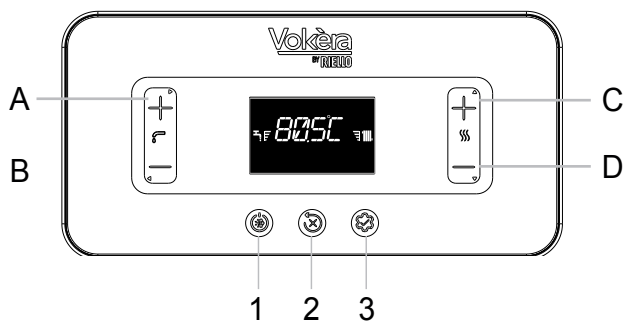

















 If no buttons are pressed, the interface automatically exits the INFO menu after 60 sec.

INFO NAME	DESCRIPTION	
I001	Screed heating hours	Number of hours spent with screed heater function (when in operation)
I002	CH probe	Boiler flow sensor value
I003	Return probe	Boiler return temperature sensor value
I004	DHW probe	DHW probe value when instantaneous boiler
I005	DHW set	Boiler DHW setpoint or from OT+ when chrono connected
I008	Exhaust probe	Flue gas probe value
I009	Outdoor temp probe	Instantaneous outdoor temperature sensor value
I010	Filtered outdoor temp	Filtered outdoor temperature sensor value used in the temperature control algorithm to calculate the heating setpoint
I011	DHW flow rate	DHW flow rate
I012	Fan speed	Number of fan rotations (rpm)
I015	Exhaust probe hours	Number of operating hours of the heat exchanger in "condensing mode" (the values are expressed in hundreds of hours, example: 01 = 100h)
I016	Main zone set	Main zone delivery setpoint
I017	OT main zone set	Main zone delivery setpoint from OT+
I018	Water pressure	System pressure
I019	DHW hour	Hours with burner on in DHW mode
I020	CH hour	Hours with burner on in heating mode
I021	DHW modulation	Average modulation percentage value with burner on in DHW mode
I022	CH modulation	Average modulation percentage value with burner on in heating mode
I023	CH supply sensor avg	Average flow sensor values with burner on in heating mode
I024	DHW supply sensor avg	Average flow sensor values with burner on in DHW mode
I025	CH return sensor avg	Average return probe values with burner on in heating mode
I026	DHW return sensor avg	Average return probe values with burner on in DHW mode
I027	Gas valve on cycle	Number of gas valve ON cycles
I029	High efficiency	If it is set to 1, it indicates the need for a drain-trap check for filling
I030	Comfort	DHS comfort
I031	SUN ON	Special functions active for high domestic water inlet temperatures
I033	PCB ID	Type of board connected
I034	PCB FW	Firmware revision of the electronic board
I035	INTERFACE FW	Interface firmware overhaul
I036	Radio signal	Indicates the quality of the WiFi connection
I039	Historical alarm 1 (oldest)	List of the last 5 alarms recorded
I040	Historical alarm 2	
I041	Historical alarm 3	
I042	Historical alarm 4	
I043	Historical alarm 5 (most recent)	
I044	Exchange service	Number of days that have elapsed since the CFS signal was activated (P707 = 0)
I046	Fw comfort development review	Not available
I047	Fw safety review	Not available
I048	Fw safety development review	Not available
I049	Fan Fw review	Not available

7. CONTROL PANEL



A	Normally used to increase the domestic hot water temperature value, when the arrow is highlighted  it carries out a confirmation function
B	Normally used to decrease the DHW temperature value, but when the arrow  is highlighted it acts as a back/annul button
A+B	Access to the DHW comfort functions (see section 5.11)
C+D	Heating time programming, status change
C	Normally used to increase the heating water temperature value, when highlighted the arrow  allows you to move within the menu P1
D	Normally used to decrease the heating water temperature value, when highlighted the arrow allows  you to move within the menu P1
A+C	Access to the clock setting menu (see section 8)
B+D	Time band programming
1	Used to modify the boiler operating status (OFF, SUMMER and WINTER)
2	Used to reset the alarm status, or to interrupt the venting cycle
3	Used to access menus INFO (press lightly) and P1 (press > 2 sec). When the  icon appears on the display, this button has an ENTER function and is used to confirm the value set while programming a technical parameter
1+3	Button lock and release
2+3	Used when the boiler is OFF, to activate the flue gas analysis function (CO)

	Indicates connection to a remote device (OTBus or RS485)
	Indicates connection to a WIFI device
	Indicates the presence of an outdoor temperature sensor
	Indicates the activation of special DHW functions, or the presence of a solar thermal management system
	Lights up if an alarm is triggered
	Lights up in the event of a fault together with the icon  , excluding flame and water alarms
	Indicates presence of a flame, in the event of a flame lockout the icon appears 
	Flashes with temporary water alarms, steady with definitive alarms
	Lights up in the presence of alarms requiring manual release by the operator
	Lights up when confirmation is required
	When this icon is active, the “confirm” function of button A is active
	When this icon is active, the “back/annul” function of button B is active
	When this icon is active, the user can navigate the menu or increase the value of the selected parameter
	When this icon is active, the user can navigate the menu or decrease the value of the selected parameter
	Lights up if heating mode is active; flashes with a heating request in progress
	Lights up if DHW mode is active; flashes with a DHW request in progress
	Indicate the set point level (1 notch minimum value, 4 notches maximum value)
1 2 3 4 5 6 7	Indicate the days of the week
AUTO ON	Time band programming
MAN ON	Manual time programming ON
MAN OFF	Manual time programming OFF

8. DETAILED INSTRUCTIONS FOR USE

- Turn the main system switch ON.
- Open the gas tap to allow the flow of fuel.
- With power on the backlight comes on, all icons and segments light up for 1sec and the firmware revision of the control board is displayed for 3sec:



If not set, the programming of the time and day of the week is automatically requested when the device is switched on. The main screen shows the icons ▲, ▼, ► and ◀ and ENTER while 00:00 is displayed with the first two digits flashing at a frequency of 0.5 sec ON, 0.5 sec OFF.

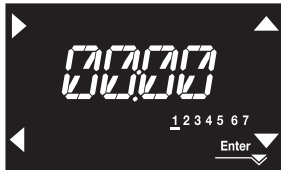

To set the time and day, proceed as follows:

- set the time with the arrows ▲ and ▼, then confirm with the key A
- set the minutes with the arrows ▲ and ▼, then confirm with the key A
- set the day of the week using the arrows ▲ and ▼. The segment at the selected day blinks, press the MENU button at the icon Enter to confirm the time and day setting. The clock will flash for 4 seconds, then the main screen will be displayed again
- to quit the time programming function without saving the new values, just press the ◀ button.

NOTE: It is also possible to change the TIME and DAY settings at a later date by accessing the SETTINGS menu, parameter P1 → P102, or by pressing the A+C for at least 2sec.

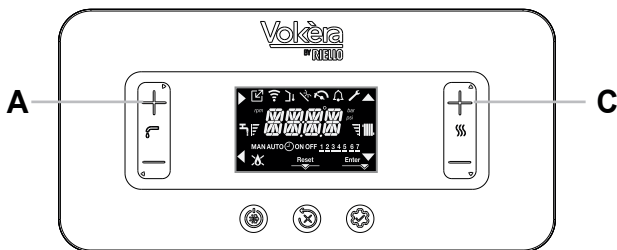

- It then starts the automatic vent cycle, if enabled, lasting 4 min (for details read section 5.8).
- The interface then shows that it was active in that moment.
-  Set the room thermostat to the desired temperature or, if the system is equipped with a chrono-thermostat or time programmer, check that it is 'on' and set.
- Then switch the boiler to WINTER or SUMMER.

8.1 TIME BAND SCHEDULING FUNCTION (ROOM THERMOSTAT)

If the heating system is managed by a room thermostat, and therefore has no time programming, the time programming on the boiler interface can be enabled setting the parameter P4 → P421 = 1.

To activate the automatic heating time programming menu, press the buttons B+D for at least 2sec in the main screen.

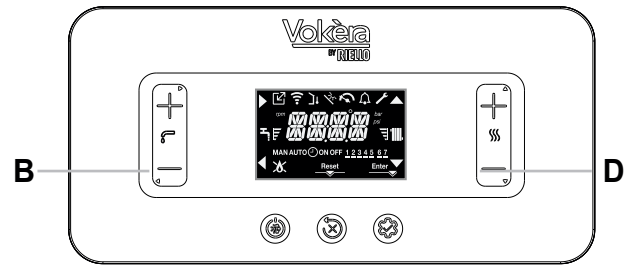

The display appears as follows:

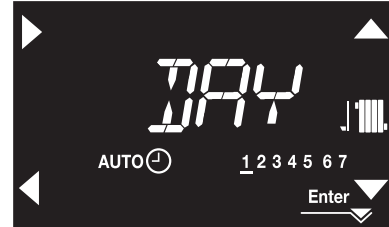

Use the arrows ▲, ▼ to select the day or group of days:
 1-2-3-4-5-6-7 individual day programming
 1-5 programming Monday to Friday
 6-7 programming from Saturday to Sunday
 1-7 whole week's programming

Use the key ► to confirm your choice and move on to the programming of time slots, use the key Enter to exit the time menu confirming the modifications made.

Use the key ◀ to exit programming and cancel the selections made.

Setting Time Bands

- The display shows TIME ON 1, press ► to set the ON time, use ▲, ▼ to modify the time, confirm with ►.
- The display shows TIME OFF 1, press ► to set the OFF time, use ▲, ▼ to modify the time, confirm with ►.
- TIME ON 2 appears, then resume programming the time bands until the maximum number of programmable bands (four) is reached, or press Enter to confirm the time bands and move on to the next day's programming.

Outside of these time bands, the room thermostat heat requests are not considered.

The **heating** time bands enabled by default are:

- MONDAY to FRIDAY: 07:30 ÷ 08:30 / 12:00 ÷ 13:30 / 18:00 ÷ 22:30
- SATURDAY to SUNDAY: 08:00 ÷ 22:30.

When heating time programming is enabled, pressing the buttons C+D allows you to switch between AUTO and MAN ON or MAN OFF time programming.

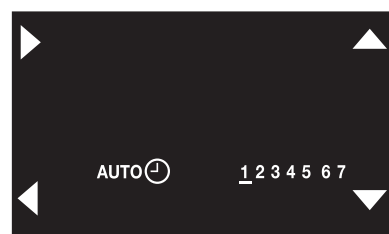
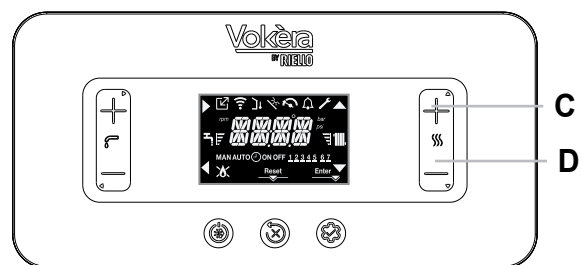

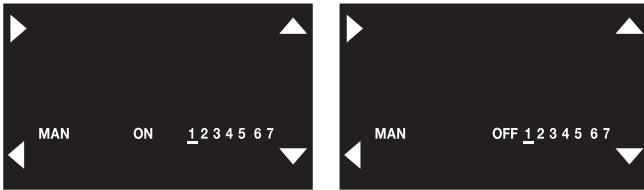

8.2 OPERATING STATUS

- By pressing button 1, the type of operation changes cyclically from OFF - SUMMER - WINTER and finally OFF again.
- If no key is pressed for 60 seconds, the interface goes into stand-by mode. Normally the pressure value is displayed, unless there has been a request for heat (in which case the temperature is displayed). If the time is set, the pressure value is replaced by the current time.

OFF

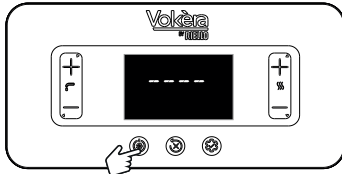

stand-by

heating delivery temperature

DHW temperature

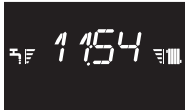

WINTER MODE

The boiler activates the heating and DHW function, the presence of the icon indicates a heat request and burner ignition.

WINTER MODE

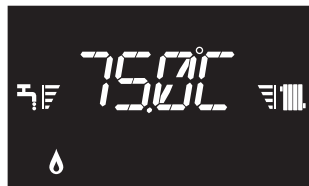

SUMMER MODE

The boiler activates the traditional DHW-only function.

SUMMER MODE

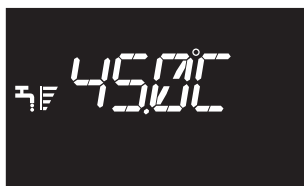

8.3 HEATING SETPOINT SETTING

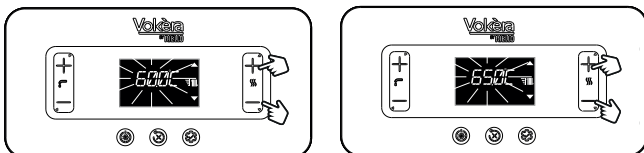

first press

second press
set CH setpoint value in steps of 0.5 °C

If no key is pressed for 5 sec., the set value is taken as the new heating setpoint.

8.4 HEATING SETPOINT SETTING WITH OUTDOOR TEMPERATURE SENSOR

With the outdoor temperature sensor connected (optional) and temperature control enabled (parameter P4 → P418=1), the delivery temperature value is chosen automatically by the system, which quickly adjusts the room temperature according to changes in the outdoor temperature.

Modification of the heating setpoint

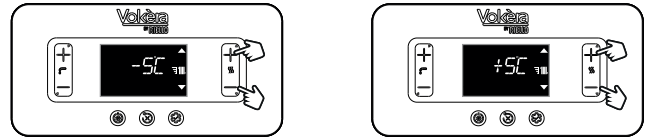

The setpoint correction is in the range (-5 - +5 °C)

With parameter P4 → P418=0 the boiler works at a fixed point.

8.5 DHW SETPOINT ADJUSTMENT

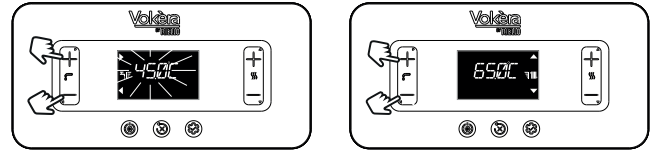

first press

second press
set DHW setpoint value in steps of 0.5 °C

If no key is pressed for 5 sec., the set value is taken as the new DHW setpoint.

8.6 SAFETY STOP

If faults arise in ignition or operations, the boiler makes a "SAFETY STOP": The display shows the error code encountered. For details see section 5.19.

Reset function

Contact the Technical Assistance Centre if unlocking attempts fail to reactivate regular operation.

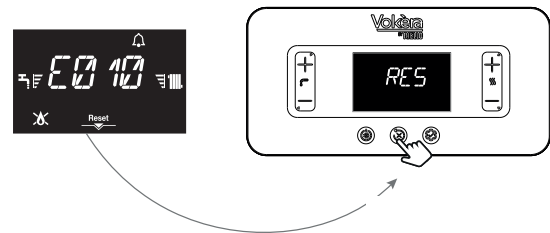

8.7 TEMPORARY SHUT-DOWN

In the event of temporary absences (weekends, short breaks, etc.) set the status of the boiler to OFF.

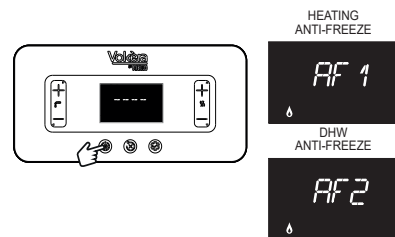

While the electrical supply and the fuel supply remain active, the system is protected by the following functions:

- heating anti-freeze:** the function starts if the temperature detected by the flow sensor falls below 5°C. In this phase a heat request is generated with burner ignition at minimum output, which is maintained until the water delivery temperature reaches 35°C; the display shows AF1
- DHW anti-freeze:** the function starts if the temperature detected by the DHW probe falls below 5°C. In this phase a heat request is generated with burner ignition at minimum output, which is maintained until the water delivery temperature reaches 55°C; the display shows AF2
- anti-lockout circulator:** the circulator is activated every 24 hours for a stop period of 30 seconds.

8.8 SWITCHING OFF FOR LONG PERIODS



If the boiler is not used for a long period of time, the following operations must be carried out:

- set the system to OFF
- set the main system switch to "off"
- turn off the fuel and water taps of the heating and domestic hot water system.

In this case, the anti-freeze and anti-locking systems are deactivated. Drain the heating and domestic water system if there is any risk of freezing.

8.9 KEYPAD LOCKOUT FUNCTION



To lock the keys

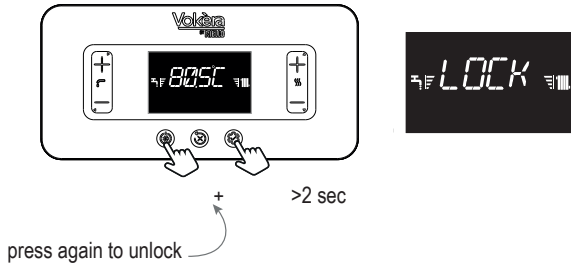

In the presence of a fault, key 2 remains active to allow the alarm to be reset.

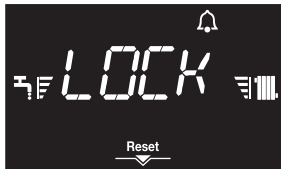

8.10 ALARM HISTORY



The alarm history is activated with parameter P7 → P701=1 (SERVICE).

Alarms can be viewed as follow:

- INFO menu (I039 to I043), in chronological order, from newest to oldest, up to a maximum of 5.

If an alarm occurs several times consecutively, it is saved only once.

To reset the alarm, follow the indications given in section 8.6.

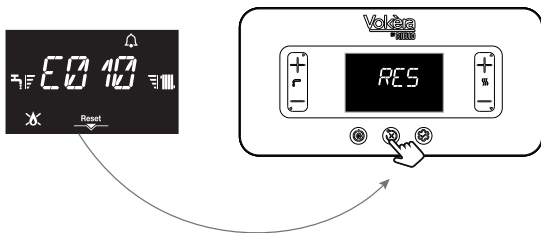

8.11 CONNECTIVITY MENU



Before connecting the "Hi, Comfort T300 or K100" devices, it is necessary to correctly set P801=2 (in the P8 CONNECTIVITY menu) to avoid communication error problems as indicated below.

Remote management of the boiler can be done via:

- Wi-Fi key

When the key (Hi, Comfort K100) is present and recognised, the icon lights up, and if it is connected to the network, the fixed icon also lights up (if the key is not connected, the icon blinks).

In the INFO menu under I036 (RADIO SIGNAL), the radio signal strength can be displayed (0 = very weak, 1 = weak, 2 = good, 3 = excellent, 4 = very good).



or

- Modbus remote control (Hi, Comfort T300)



Even when Hi, Comfort T300 is connected, the boiler interface continues to be operational. It is possible to modify the value of some parameters both from T300 and from the boiler interface, in the latter case Hi, Comfort T300 could signal a PARAMETERS INCOMPATIBLE message: choose the T300 option to restore the previous value of the modified parameter or GP to confirm the change made.

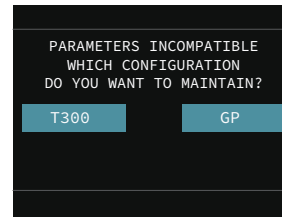

Note: The parameters relating to the BUZZER and COMBUSTION CONTROL functions cannot be modified from the T300.

It is also possible to activate remote management via an OpenTherm chronothermostat:



The Hi, Comfort T300 and K100 remote controls cannot be connected to the boiler at the same time while, if taken individually, they can coexist with the T100 remote control.

Note: the T100 remote control cannot be connected to the boiler if the system is hybrid (presence of a heat pump).

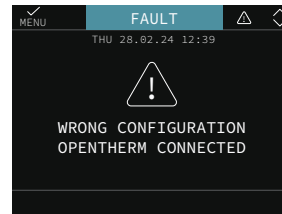

8.12 FEEDER BOTTLE FUNCTION



The feeder bottle function blocks the DHW setpoint value to prevent it from being accidentally modified.

To activate this function, from the DHW set point screen:

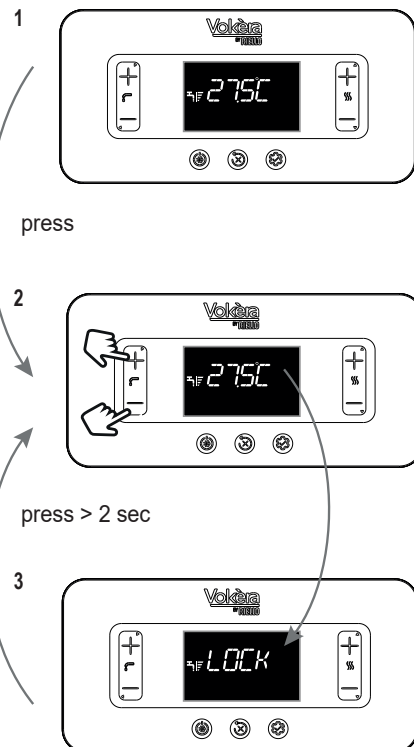

to deactivate "LOCK" press again

9. SECTION - SERVICING INSTRUCTIONS

GENERAL

Once the appliance has been serviced, the benchmark Service Record must be completed.

For UK only

It is important that the Benchmark Service Record is correctly completed and handed to the user. Failure to install and commission the appliance to the manufacturers instructions will invalidate the warranty.

To ensure the continued safe and efficient operation of the appliance, it is recommended that it is checked and serviced at regular intervals. To ensure correct and safe operation of the appliance, it is essential that any worn or failed component be replaced only with a **genuine Vokèra spare part**. It should be remembered that although certain generic components may look similar, they will be specific to an individual appliance or product range. Use of non-genuine Vokèra spare parts could invalidate your warranty and may pose a potential safety hazard. The frequency of servicing will depend upon the particular installation conditions, but in general, once per year should be sufficient. It is the law that any servicing work is carried out by competent person such as a Vokèra engineer, an approved service agent, British Gas, GAS SAFE registered personnel or other suitably qualified personnel. The following instructions apply to the appliance and its controls, but it should be remembered that the central heating and the domestic hot water systems would also require attention from time to time.

ROUTINE ANNUAL MAINTENANCE

The appliance incorporates many 'state-of-the-art' components that are either 'solid-state' or are regarded as 'non-serviceable' items. As a consequence, the requirements for routine annual maintenance are focussed upon:

1. ensuring that the appliance and flue system are in a safe condition
2. ensuring that the appliance is operating safely
3. ensuring that the appliance is performing to its design specification.

When the appliance has been installed to within the minimum stated clearances; the appliance layout is such that it enables routine annual maintenance to be carried out entirely from the front of the appliance.

NOTE

Any noticeable defect or deterioration on or within the appliance and flue system that impacts or affects the above requirements; will warrant further diagnosis and repair, which may result in the replacement of components.

Specific advice and instruction on the removal and replacement of component parts of the appliance can be found online using the adjacent QR code or by visiting our website.

ROUTINE ANNUAL MAINTENANCE REQUIREMENTS

1. Check the operation of the appliance in both the heating and hot water modes and ensure the performance is in line with the appliance specification.
2. Using the UI menu, navigate to the alarms history and check for any recent alarm events.
Refer to the alarm/fault codes description chart for further information.
3. Remove the front cover (see section 4.5) and visually inspect the internal components and electrical wiring for any defect or deterioration.
4. Visually check for any dirt or debris within the condensate trap (the trap is translucent and can be checked visually).
5. Replace the front cover as detailed in section 4.5 taking notice of the importance of ensuring that the effectiveness of the – front cover – seals are not compromised.
6. Carry out a combustion analysis as detailed in section 5.15.
7. Visually check the entire flue system for any damage, defect, or deterioration.

NOTE

In order to access the 'alarms history' it is necessary to access the password protected settings. Refer to section 6.1 for further details.

UNSCHEDULED MAINTENANCE

The appliance incorporates software that monitors the operating conditions of the appliance, and will record any 'unusual usage conditions' that will affect the requirement to remove and clean the burner/heat exchanger assembly. When the 'unusual usage' hours reach a pre-determined threshold, the appliance will signal – via alarm code E091 – that the heat exchanger requires to be cleaned.

REPLACEMENT OF COMPONENTS

Although it is anticipated that this appliance will provide years of trouble-free service and outstanding performance; the lifespan of any component will be determined by factors such as operating conditions and usage levels. Should the appliance develop a fault, the fault-finding section of this manual will greatly assist in determining the cause; however further advice can be sought from the Vokera Technical Help-line. Remember always to use only genuine Vokera spare parts.

COMPONENT REMOVAL PROCEDURE

To remove/replace a component, access to the interior of the appliance is usually essential.

Always isolate the appliance from the electrical supply – and if necessary remove the fuse.

- Close all service valves if any hydraulic and/or gas carrying item is to be removed.
- Remove the front cover – and where necessary or convenient – the side panels of the appliance as detailed in 4.5.
- If required, drain the primary circuit via the drain valve (located adjacent to the diverter valve) using the tubing supplied with the appliance.
- If required, drain the secondary circuit via the available DHW outlets.

NOTE

When removing a hydraulic component, ensure that some water absorbent cloths are available to catch any residual water that may drip from the appliance and/or the removed component.

When the appliance has been installed to within the stated minimum clearances; it may be necessary to remove adjacent components in order to facilitate access to a specific component.

Carry out the relevant elements of the commissioning procedure (section 5) after replacing a component.

ALWAYS TEST FOR GAS TIGHTNESS IF ANY GAS CARRYING COMPONENT HAS BEEN DISTURBED, REMOVED, OR REPLACED.

WHEN REPLACING THE SIDE PANELS AND/OR THE FRONT COVER, ENSURE THE ROOM SEALED INTEGRITY OF THE APPLIANCE HAS NOT BEEN COMPROMISED – REFER TO 4.5.

To obtain detailed specific information and instructions on how to remove and replace specific components, please access our online resources by logging on to our website.

www.vokera.co.uk

www.vokera.ie

10. SECTION - CHECKS, ADJUSTMENTS AND FAULT FINDING

NOTE: please refer to section 3, section 3.1 and use the appropriate PPE when carrying out any of the actions or procedures contained within this section.

10.1 CHECKING APPLIANCE OPERATION

When carrying out any repairs or servicing to the appliance, the relevant commissioning procedure must be undertaken to ensure the continued safe operation of the appliance. Particular attention should be made to ensure gas tightness, water tightness and the electrical integrity of the appliance.

10.2 APPLIANCE MODES OF OPERATION

NOTE: there must be sufficient system water pressure (min. 0.4 bar) to ensure the water pressure switch is activated. If there is insufficient system pressure the pump and fan will be prevented from operating and the low-pressure fault code will be indicated.

10.2.1 OFF

When the appliance has been set to OFF via the UI, the following functions will remain active:

- frost-protection system
- pump & actuator anti-block.

10.2.2 ON-BOARD FUNCTIONS

- **FROST-PROTECTION:** this function is only active when there are no requests for heating or HW. If the temperature drops below 5°C, the boiler will operate on minimum power until the temperature of the thermistors reaches 35°C for CH and 55°C for DHW. Thereafter the pump & fan will over-run for 30-seconds.
- **ANTI-CYCLE FUNCTION:** the anti-cycle function ensures the burner remains switched off for at least 3-minutes after the set-point hysteresis (set-point + 5-deg) for CH heat request.
- **PUMP ANTI-BLOCK FUNCTION:** when there has been no heating or HW request for 24-hours, the anti-block cycle is activated. The pump will be activated for a period of 30-seconds.
- **ACTUATOR ANTI-BLOCK FUNCTION:** when there has been no heating or HW request for 24-hours, the anti-block cycle is activated. The diverter valve actuator will motor briefly to the heating position, and then back to the DHW position. The pump will run briefly.
- **DHW PRE-HEAT FUNCTION:** when the DHW pre-heat function is enabled, the appliance will light periodically to maintain the temperature of the DHW heat exchanger. When the DHW thermistor and the primary thermistor fall below 35°C and 55°C respectively, the boiler will fire on minimum +25% power until the primary thermistor exceeds 55°C. Thereafter the pump will over-run for a period of 30-seconds.

10.2.3 HEATING MODE

When a 'heating' request is generated via the connected external control/s and/or the UI, the appliance will operate in the heating mode. The pump and fan will be activated via the flow temperature sensor. When the fan is sensed to be operating correctly (tacho signal), the ignition sequence commences. Ignition is sensed by the electronic circuit to ensure flame stability at the burner. Once successful ignition has been achieved, the electronic circuitry increases the gas rate to 75% for a period of 15 minutes.

The speed of the fan and therefore the output of the boiler is determined by the temperature of the water sensed by the flow temperature sensor, consequently a high temperature at the flow sensor results in a lower fan speed. As the water temperature increases, the temperature sensors – located on the flow pipe of the boiler – reduce the fan speed via the electronic circuitry. Depending on the load, either the water temperature will continue to rise until the set point is achieved or the water temperature will fall whereby fan speed will increase

relative to the output required. When the boiler has reached the set point (+ hysteresis), the burner will switch off. The built-in anti-cycle device prevents the burner from re-lighting for approximately 3-minutes.

When the temperature of the flow sensor falls below the set point (- hysteresis), the burner will re-light.

NOTE: if burner ignition is not detected at the first attempt, the appliance will repeat the ignition sequence another two times (3-times in total) before going to lockout. When the set-point has been reached as measured at the primary thermistor, the appliance will begin the modulation phase whereby the fan and gas valve will continuously modulate to maintain the set-point. If the temperature continues to rise and exceeds the set-point by 5°C (hysteresis), the burner will shut down. A new ignition sequence will be enabled when the 3- minute anti-cycle has been performed and the temperature at the primary thermistor has dropped 5°C (hysteresis) below the set-point.

10.2.4 DHW MODE

The appliance will operate in the hot water mode whenever a DHW outlet is opened. The appliance flowmeter will detect water movement (min 2L/pm) and signal a hot water request whereupon the pump and fan will be activated via the flow temperature sensor. When the fan is sensed to be operating correctly (tacho signal), the ignition sequence commences. Ignition is sensed by the electronic circuitry to ensure flame stability at the burner. Once successful ignition has been achieved, the electronic circuit allows the gas rate to achieve the modulation value.

NOTE: when the request for heating and/or hot water has been satisfied, the appliance pump and fan may continue to circulate to dissipate any residual heat within the appliance.

ATTENTION

Gas type and appliance outputs are factory set by default, at the values declared in the specification data in section 2.

Vokera cannot accept any responsibility for any damage or malfunction that has been caused as a result of tampering or incorrect set up of this appliance during installation or commissioning.

10.3 CHECKING THE EXPANSION VESSEL

Carry out the component removal procedure. You must ensure that the boiler is completely drained of water. Using a suitable pressure gauge, remove dust cap on expansion vessel and check the charge pressure. The correct charge pressure should be 1.0 bar ± 0.1 bar. If the charge pressure is less, use a suitable pump to increase the charge.

NOTE: you must ensure the drain valve is in the open position whilst re-charging takes place. Replace the dust cap and carry out the relevant commissioning procedure (section 5).

10.4 EXTERNAL FAULTS

Before carrying out any faultfinding or component replacement, ensure the fault is not attributable to any aspect of the installation.

10.4.1 INSTALLATION FAULTS

Symptom	Possible cause
No ignition	Check wiring/check electrical supply/check gas supply
No hot water	Check pipe-work
No heating	Check external controls

Fault	Possible cause
Fault code	Check gas supply, check flue system

10.5 ELECTRICAL CHECKS

Any electrical checks must be carried out by a suitably qualified person.

10.5.1 EARTH CONTINUITY TEST

Isolate the appliance from the electrical supply, and using a suitable multi-meter carry out a resistance test. Connect test leads between an appliance earth point and the earth wire of the appliance supply cable. The resistance should be less than 1 OHM. If the resistance is greater than 1 OHM check all earth wires and connectors for continuity and integrity.

10.5.2 SHORT CIRCUIT CHECK

Isolate the appliance from the electrical supply, and using a suitable multi-meter, carry out a short circuit test between the Live & Neutral connections at the appliance terminal strip. Repeat above test on the Live & Earth connections at the appliance terminal strip.

NOTE

Should it be found that the fuse has failed but no fault is indicated, a detailed continuity check will be required to trace the fault. A visual inspection of components may also assist in locating the fault.

10.5.3 POLARITY CHECK

With the appliance connected to the electrical supply and using a suitable multimeter, carry out the following voltage tests:

- connect test leads between the Live & Neutral connections at the appliance terminal strip. The meter should read approximately 230V ac. If so proceed to next stage. If not, check electrical supply and fuses.
- connect test leads between the Live & Earth connections at the appliance terminal strip. The meter should read approximately 230V ac. If so proceed to next stage. If not, check wiring.
- connect test leads between the Neutral & Earth connections at the appliance terminal strip. The meter should read approximately 0 – 15Vac. If so polarity is correct. If not, see section 10.6.

10.5.4 REVERSED POLARITY OR SUPPLY FAULT

Repeat the above tests at the appliance isolator, if testing reveals correct polarity and/or supply at the isolator, re-check wiring and connections between the isolator and the appliance. If tests on the isolator also reveal reversed polarity or a supply fault, consult the local electricity supplier for advice.

DISTANCE TO EARTH CHECK

Isolate the appliance from the electrical supply, and using a suitable multi-meter carry out a resistance test. Connect test leads between the Live & Earth connections at the appliance terminal strip. If the meter reads other than infinity there is a fault that must be isolated, carry out a detailed continuity check to identify the location of the fault.

These series of checks must be carried out before attempting any faultfinding procedures on the appliance. On completion of any task that required the disconnection and re-connection of any electrical wiring or component, these checks must be repeated.

10.6 FAULT FINDING

Before attempting any faultfinding, the electrical checks as detailed in section 10.5 must be carried out. Isolate the appliance from the electrical supply.

Disconnect any external controls from terminal plug, and insert a link-wire between the two wires at the 'TA' connections of the CE8 connector.

NOTE: restore the electrical supply to the boiler and RESET functioning. The boiler should now function as described in section 10.2. Should the boiler fail to respond, the internal fuses and connectors should be checked to ensure integrity and continuity.

10.7 APPLIANCE STATUS AND FAULT CODES

When the boiler detects a temporary fault condition, the appropriate code is shown. If/when the fault is final, the pump will perform 30 to 60-second post circulation (depending on the error code) and fault code will be displayed. For combustion fault, FAN can also post vent up to 5min if required.

10.8 TYPICAL HI-COMFORT CONNECTION – CONNECTED TO THE CE8 CONNECTOR

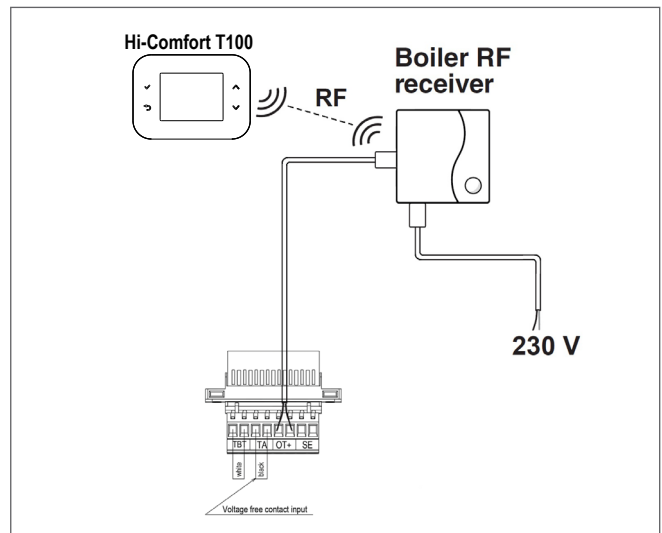

10.9 TYPICAL CONNECTION FROM REMOTE ROOM THERMOSTAT AND CLOCK – CONNECTED TO THE CE8 CONNECTOR

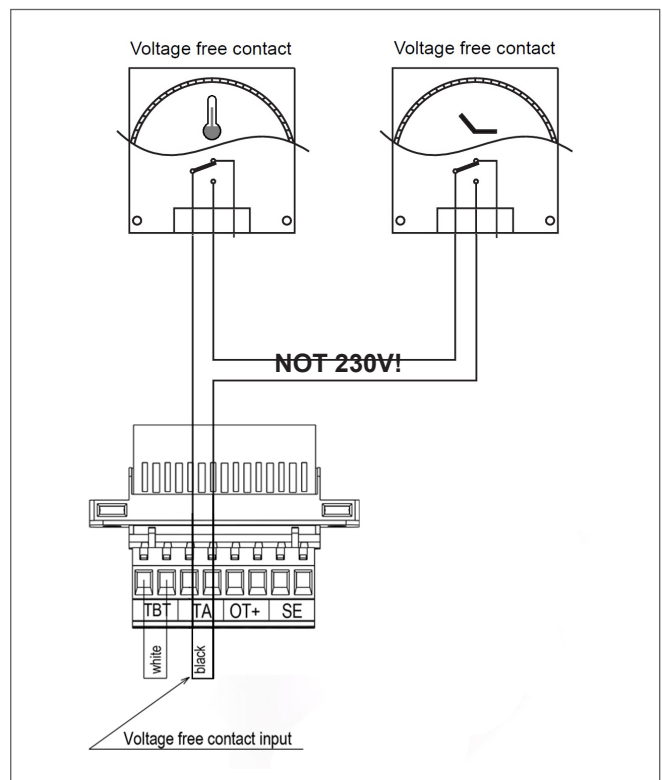

FUNCTIONAL DIAGRAM

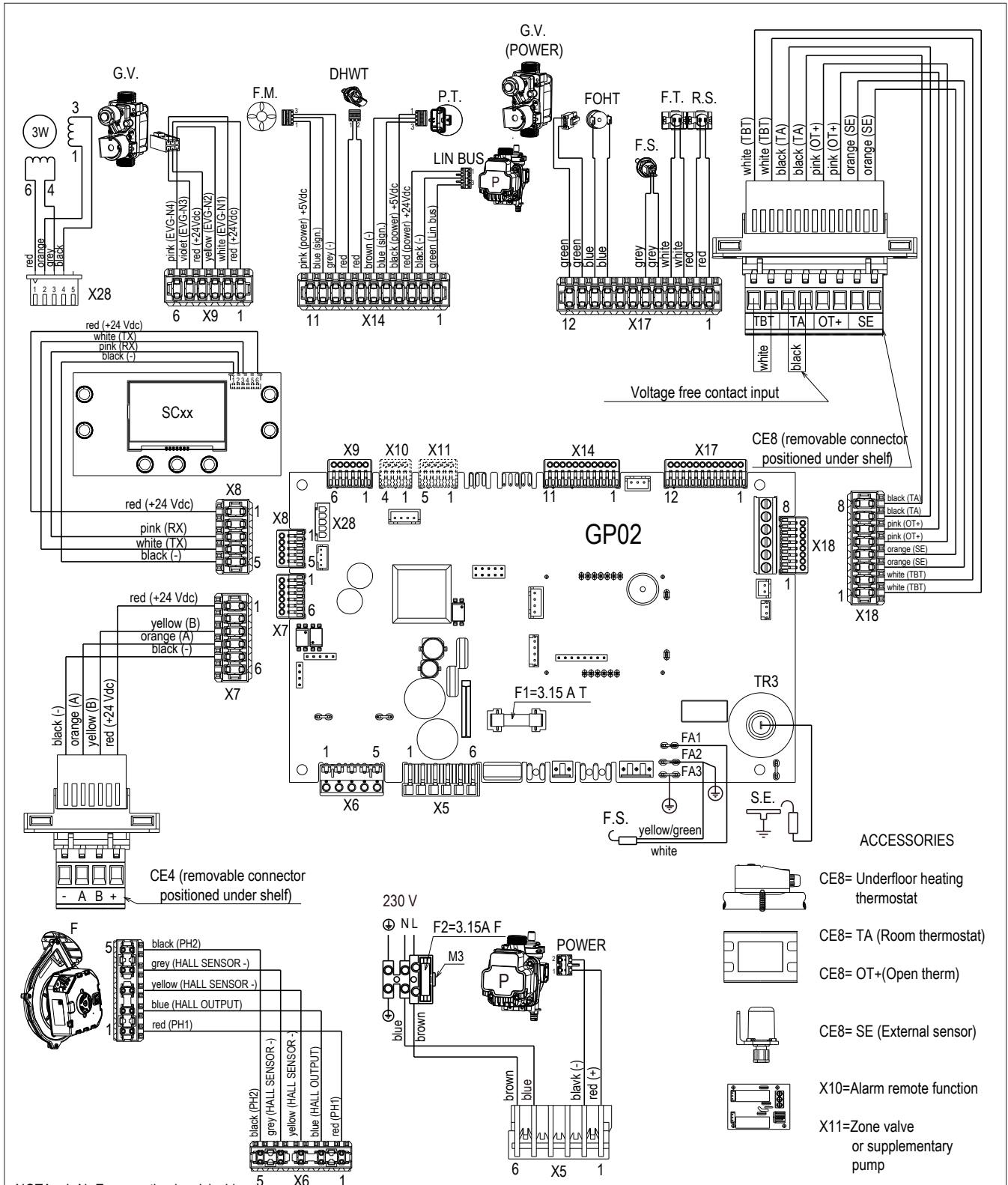

NOTA : L-N-E connection is advisable

- GP02** Regulation board and combustion controller
- SCxx** Control panel
- X1-X28** Link connectors (X10 – X11 accessories)
- TR3** Ignition transformer
- F1** Fuse 4A T
- S.E.** Spark electrode
- P (power)** Pump 325 Vdc
- M3** Terminal strip for electrical connection high power
- F2** Fuse 3.15A F
- F** Fan 325 Vdc
- CE4** External link connector: (- A B +) Bus 485
- 3W** 3 way valve stepper motor

- G.V** Gas valve stepper 24 Vdc
- F.M.** Flow meter
- D.H.W.T.** Domestic hot water temperature
- P.T.** Pressure transducer
- P (Lin Bus)** Pump signal Lin Bus
- G.V. (power)** Gas valve power 24 Vdc
- F.O.H.T** Flow over heat thermostat
- FS** Flue sensor
- FT** Flow thermistor
- RS** Return thermistor
- CE8** External link connector (accessories):

- ACCESSORIES**
- CE8= Underfloor heating thermostat
 - CE8= TA (Room thermostat)
 - CE8= OT+(Open therm)
 - CE8= SE (External sensor)
 - X10=Alarm remote function
 - X11=Zone valve or supplementary pump

11. SECTION - LPG INSTRUCTIONS

11.1 RELATED DOCUMENTS

BS 6798		INSTALLATION OF BOILERS OF RATED INPUT NOT EXCEEDING 60 kW
BS EN 12828		DESIGN FOR WATER-BASED HEATING SYSTEMS
BS 5446		INSTALLATION OF GAS HOT WATER SUPPLIES FOR DOMESTIC PURPOSES
BS 5440	PARTS 1 & 2	FLUES & VENTILATION
BS 6891		SPECIFICATION FOR THE INSTALLATION AND MAINTENANCE OF LOW PRESSURE GAS INSTALLATION PIPEWORK OF UP TO 35 mm

11.2 TECHNICAL DATA

Gas Pressures	SYNERGY 25C	SYNERGY 30C	SYNERGY 35C
Inlet pressure	37.0 mbar	37.0 mbar	37.0 mbar
Maximum gas rate (CH)	1.55 (kg/h)	1.94 (kg/h)	2.33 (kg/h)
Maximum gas rate (DHW)	1.94 (kg/h)	2.33 (kg/h)	2.71 (kg/h)
Minimum gas rate (CH)	0.19 (kg/h)	0.27 (kg/h)	0.27 (kg/h)
Minimum gas rate (DHW)	0.19 (kg/h)	0.27 (kg/h)	0.27 (kg/h)
Maximum number of heating fan rotations	6,100 (rpm)	5,800 (rpm)	7,100 (rpm)
Maximum number of DHW fan rotations	7,600 (rpm)	7,100 (rpm)	8,200 (rpm)
Minimum number of heating fan rotations	1,250 (rpm)	1,250 (rpm)	1,250 (rpm)
Minimum number of DHW fan rotations	1,250 (rpm)	1,250 (rpm)	1,250 (rpm)
Emissions	SYNERGY 25C	SYNERGY 30C	SYNERGY 35C
NOx (max-min)	50 - 50 p.p.m.	40 - 40 p.p.m.	40 - 40 p.p.m.
CO (max-min)	250 - 20 p.p.m.	250 - 20 p.p.m.	240 - 20 p.p.m.
CO ₂ (max-min) *	10.0 - 10.0 %	9.9 - 10.0 %	9.9 - 10.0 %

(*) CO₂ tolerance= +1% -1%

11.3 APPLIANCE RE-CONFIGURATION FOR LPG

WARNING!

The gas supply to the appliance must remain turned OFF until the following procedure has been completed.

Refer to section 5.17 Gas Conversion and follow the step by step instructions. Once the gas conversion procedure has been completed, carry out a GAC procedure (see section 5.9) and - if necessary - adjust to the appropriate fan speed/s found above and in section 5.16.

NOTE: the appliance gas valve is factory set and therefore non-adjustable. Do not attempt to adjust or interfere with the settings of the gas valve, as to do so, will cause the appliance to malfunction and may lead to serious damage.

The boiler DOES NOT require additional adjustments.



The boiler may only be converted by qualified staff.



After conversion apply the LPG label to the appliance data plate (LPG label is contained within the documentation pack).

COMMISSIONING: CO AND COMBUSTION RATIO CHECK

BEFORE CO AND COMBUSTION RATIO CHECK

The installation instructions should have been followed, gas type verified and gas supply pressure/rate checked as required prior to commissioning.

As part of the installation process, **ESPECIALLY WHERE A FLUE HAS BEEN FITTED BY PERSONS OTHER THAN THE BOILER INSTALLER**, visually check the integrity of the whole flue system to confirm that all components are correctly assembled, fixed and supported. Check that the maximum flue lengths have not been exceeded and all guidance has been followed (e.g. Technical Bulletin 008).

The flue gas analyser should be of the correct type, as specified by BS 7967.

Before use, the flue gas analyser should have been maintained and calibrated as specified by the manufacturer. The installer must have the relevant competence for use of the analyser.

Check and zero the analyser **IN FRESH AIR**, as per analyser manufacturer's instructions.

NOTE

The air/gas ratio valve is factory-set and must not be adjusted during commissioning unless this action is recommended, following contact with the Vokera technical help line. If any such adjustment is recommended and further checking of the boiler is required, the engineer must be competent to carry out this work and to use the flue gas analyser accordingly. If the boiler requires conversion to operate with a different gas family (e.g., conversion from natural gas to LPG) separate guidance will be provided by the Vokera technical help line and must be followed.

SET BOILER TO MAXIMUM RATE

In accordance with, section 7.3, set boiler to operate at maximum rate (full load condition). Allow sufficient time for combustion to stabilise. , insert analyser probe into air inlet sampling point.

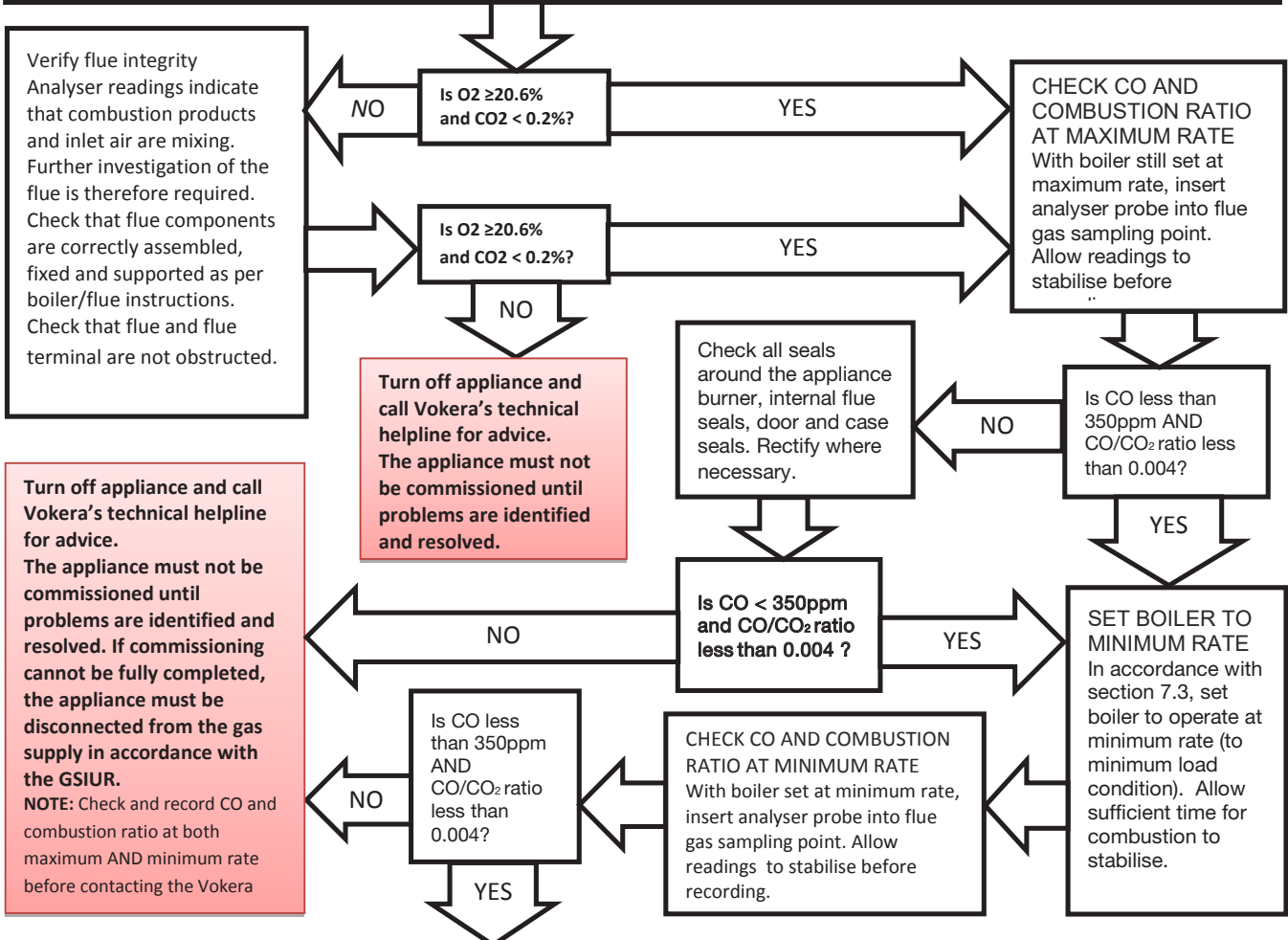

Boiler is operating satisfactorily No further actions required.

Ensure test points are capped, boiler case is correctly replaced and all other commissioning procedures are completed. Complete Benchmark Checklist, recording CO and combustion ratio readings as required.

Benchmark Commissioning & Warranty Validation Service Record

It is a requirement that the boiler is installed and commissioned to the manufacturers' instructions and the data fields on the commissioning checklist completed in full.

To instigate the boiler warranty the boiler needs to be registered with the manufacturer within one month of the installation. The warranty rests with the end-user (consumer), and they should be made aware it is ultimately their responsibility to register with the manufacturer, within the allotted time period.

It is essential that the boiler is serviced in line with the manufacturers' recommendations, at least annually. This must be carried out by a competent Gas Safe registered engineer. The service details should be recorded on the Benchmark Service and Interim Boiler Work Record and left with the householder. Failure to comply with the manufacturers' servicing instructions and requirements will invalidate the warranty.



www.hhic.co.uk

This Commissioning Checklist is to be completed in full by the competent person who commissioned the boiler as a means of demonstrating compliance with the appropriate Building Regulations and then handed to the customer to keep for future reference.

Failure to install and commission according to the manufacturers' instructions and complete this Benchmark Commissioning Checklist will invalidate the warranty. This does not affect the customer's statutory rights.

All installations in England and Wales must be notified to Local Authority Building Control (LABC) either directly or through a competent Persons Scheme. A Building Regulations Compliance Certificate will then be issued to the customer.

Heating and Hotwater Industry Council (HHIC)



www.centralheating.co.uk

GAS BOILER SYSTEM COMMISSIONING CHECKLIST & WARRANTY VALIDATION RECORD

Address:															
Boiler make and model:															
Boiler serial number:															
Commissioned by (PRINT NAME):						Gas Safe registration number:									
Company name:						Telephone number:									
Company email:						Company address:									
										Commissioning date:					
Heating and hot water system complies with the appropriate Building Regulations?											Yes				
Optional: Building Regulations Notification Number (if applicable):															
Time, temperature control and boiler interlock provided for central heating and hot water											Yes				
Boiler Plus requirements (tick the appropriate box(s))															
Boiler Plus option chosen for combination boiler in ENGLAND						Weather compensation			Smart thermostat with automisation and optimisation						
						Load compensation			Flue Gas Heat Recovery						
Time and temperature control to hot water			Cylinder thermostat and programmer/timer						Combination boiler						
Zone valves			pre-existing			Fitted			Not required						
Thermostatic radiator valves			pre-existing			Fitted			Not required						
Automatic bypass to system			pre-existing			Fitted			Not required						
Underfloor heating			pre-existing			Fitted			Not required						
Water quality															
The system has been flushed, cleaned and a suitable inhibitor applied upon final fill, in accordance with BS7593 and boiler manufacturers' instructions											Yes				
What system cleaner was used?						Brand:			Product:						
What inhibitor was used?						Brand:			Product:						
Primary water system filter			pre-existing			Fitted			Not required						
CENTRAL HEATING MODE measure and record (as appropriate)															
Gas rate (for combination boilers complete DHW mode gas rate)						m ³ /hr			or			ft ³ /hr			
Central heating output left at factory settings?						Yes			No						
If no, what is the maximum central heating output selected?												kW			
Dynamic gas inlet pressure												mbar			
Central heating flow temperature												°C			
Central heating return temperature												°C			
System correctly balanced/rebalanced?						Yes									
COMBINATION BOILERS ONLY															
Is the installation in a hard water area (above 200ppm)?						Yes			No						
Water scale reducer/softener			pre-existing			Fitted			Not required						
What type of scale reducer/softener has been fitted?						Brand:			Product:						
Water meter fitted?						Yes			No						
If yes- DHW expansion vessel			pre-existing			Fitted			Not required						
Pressure reducing valve			pre-existing			Fitted			Not required						
DOMESTIC HOT WATER MODE Measure and record															
Gas rate						m ³ /hr			or			ft ³ /hr			
Dynamic gas inlet pressure at maximum rate												mbar			
Cold water inlet temperature												°C			
Hot water has been checked at all outlets						Yes			Temperature			°C			
CONDENSATE DISPOSAL															
The condensate drain has been installed in accordance with the manufacturers' instructions and/or BS5546/BS6798											Yes				
Point of termination						Internal			External (only where internal termination impractical)						
Method of disposal						Gravity			Pumped						
ALL INSTALLATIONS															
Record the following		At max rate:		CO		ppm		CO ₂		%		CO/CO ₂		Ratio	
		At min rate (where possible)		CO		ppm		CO ₂		%		CO/CO ₂		Ratio	
Where possible, has a flue integrity check been undertaken in accordance with manufacturers' instructions, and readings are correct?											Yes				
The operation of the boiler and system controls have been demonstrated to and understood by the customer											Yes				
The manufacturers' literature, including Benchmark Checklist and Service Record, has been explained and left with the customer											Yes				
Commissioning Engineer's signature															
Customer's signature (To confirm satisfactory demonstration and receipt of manufacturers' literature)															

* All installations in England and Wales must be notified to Local Authority Building Control (LABC) either directly or through a Competent Persons Scheme. A Building Regulations Compliance Certificate will then be issued to the customer.

© Heating and Hotwater Industry Council (HHIC)



www.centralheating.co.uk

SERVICE & INTERIM BOILER WORK RECORD

It is recommended that your boiler and heating system are regularly serviced and maintained, in line with manufacturers' instructions, and that the appropriate service / interim work record is completed.

Service provider

When completing a service record (as below), please ensure you have carried out the service as described in the manufacturers' instructions. Always use the manufacturers specified spare parts.

SERVICE/INTERIM WORK ON BOILER delete as appropriate					Date:	
Engineer name:		Company name:				
Telephone N°:		Gas Safe registration N°:				
Max rate	CO	ppm	CO ₂	%	CO/CO ₂	
Min rate	CO	ppm	CO ₂	%	CO/CO ₂	
Where possible, has a flue integrity check been undertaken in accordance with manufacturers' instructions, and readings are correct?*					yes	
Gas rate:	m ³ /h	OR	ft ³ /h			
Were parts fitted? ^{delete as appropriate}	Yes	No				
Parts fitted:						
System inhibitor concentration has been checked and appropriate action taken, in accordance with BS 7593 and boiler manufacturers' instructions. *					yes	n/a
Comments:						
Signature:						

*A System inhibitor efficacy test is required on every annual service in accordance with the manufacturers' instructions and BS 7593. It is only acceptable to not have undertaken this if the service engineers attendance visit was in between annual services to attend a non-water facing component.

SERVICE/INTERIM WORK ON BOILER delete as appropriate					Date:	
Engineer name:		Company name:				
Telephone N°:		Gas Safe registration N°:				
Max rate	CO	ppm	CO ₂	%	CO/CO ₂	
Min rate	CO	ppm	CO ₂	%	CO/CO ₂	
Where possible, has a flue integrity check been undertaken in accordance with manufacturers' instructions, and readings are correct?*					yes	
Gas rate:	m ³ /h	OR	ft ³ /h			
Were parts fitted? ^{delete as appropriate}	Yes	No				
Parts fitted:						
System inhibitor concentration has been checked and appropriate action taken, in accordance with BS 7593 and boiler manufacturers' instructions. *					yes	n/a
Comments:						
Signature:						

*A System inhibitor efficacy test is required on every annual service in accordance with the manufacturers' instructions and BS 7593. It is only acceptable to not have undertaken this if the service engineers attendance visit was in between annual services to attend a non-water facing component.

SERVICE/INTERIM WORK ON BOILER delete as appropriate					Date:	
Engineer name:		Company name:				
Telephone N°:		Gas Safe registration N°:				
Max rate	CO	ppm	CO ₂	%	CO/CO ₂	
Min rate	CO	ppm	CO ₂	%	CO/CO ₂	
Where possible, has a flue integrity check been undertaken in accordance with manufacturers' instructions, and readings are correct?*					yes	
Gas rate:	m ³ /h	OR	ft ³ /h			
Were parts fitted? ^{delete as appropriate}	Yes	No				
Parts fitted:						
System inhibitor concentration has been checked and appropriate action taken, in accordance with BS 7593 and boiler manufacturers' instructions. *					yes	n/a
Comments:						
Signature:						

*A System inhibitor efficacy test is required on every annual service in accordance with the manufacturers' instructions and BS 7593. It is only acceptable to not have undertaken this if the service engineers attendance visit was in between annual services to attend a non-water facing component.

SERVICE/INTERIM WORK ON BOILER delete as appropriate					Date:	
Engineer name:		Company name:				
Telephone N°:		Gas Safe registration N°:				
Max rate	CO	ppm	CO ₂	%	CO/CO ₂	
Min rate	CO	ppm	CO ₂	%	CO/CO ₂	
Where possible, has a flue integrity check been undertaken in accordance with manufacturers' instructions, and readings are correct?*					yes	
Gas rate:	m ³ /h	OR	ft ³ /h			
Were parts fitted? ^{delete as appropriate}	Yes	No				
Parts fitted:						
System inhibitor concentration has been checked and appropriate action taken, in accordance with BS 7593 and boiler manufacturers' instructions. *					yes	n/a
Comments:						
Signature:						

*A System inhibitor efficacy test is required on every annual service in accordance with the manufacturers' instructions and BS 7593. It is only acceptable to not have undertaken this if the service engineers attendance visit was in between annual services to attend a non-water facing component.

SERVICE/INTERIM WORK ON BOILER delete as appropriate					Date:	
Engineer name:		Company name:				
Telephone N°:		Gas Safe registration N°:				
Max rate	CO	ppm	CO ₂	%	CO/CO ₂	
Min rate	CO	ppm	CO ₂	%	CO/CO ₂	
Where possible, has a flue integrity check been undertaken in accordance with manufacturers' instructions, and readings are correct?*					yes	
Gas rate:	m ³ /h	OR	ft ³ /h			
Were parts fitted? ^{delete as appropriate}	Yes	No				
Parts fitted:						
System inhibitor concentration has been checked and appropriate action taken, in accordance with BS 7593 and boiler manufacturers' instructions. *					yes	n/a
Comments:						
Signature:						

*A System inhibitor efficacy test is required on every annual service in accordance with the manufacturers' instructions and BS 7593. It is only acceptable to not have undertaken this if the service engineers attendance visit was in between annual services to attend a non-water facing component.

SERVICE/INTERIM WORK ON BOILER delete as appropriate					Date:	
Engineer name:		Company name:				
Telephone N°:		Gas Safe registration N°:				
Max rate	CO	ppm	CO ₂	%	CO/CO ₂	
Min rate	CO	ppm	CO ₂	%	CO/CO ₂	
Where possible, has a flue integrity check been undertaken in accordance with manufacturers' instructions, and readings are correct?*					yes	
Gas rate:	m ³ /h	OR	ft ³ /h			
Were parts fitted? ^{delete as appropriate}	Yes	No				
Parts fitted:						
System inhibitor concentration has been checked and appropriate action taken, in accordance with BS 7593 and boiler manufacturers' instructions. *					yes	n/a
Comments:						
Signature:						

*A System inhibitor efficacy test is required on every annual service in accordance with the manufacturers' instructions and BS 7593. It is only acceptable to not have undertaken this if the service engineers attendance visit was in between annual services to attend a non-water facing component.

* All installations in England and Wales must be notified to Local Authority Building Control (LABC) either directly or through a Competent Persons Scheme. A Building Regulations Compliance Certificate will then be issued to the customer.

© Heating and Hotwater Industry Council (HHIC)



www.centralheating.co.uk

SERVICE & INTERIM BOILER WORK RECORD

It is recommended that your boiler and heating system are regularly serviced and maintained, in line with manufacturers' instructions, and that the appropriate service / interim work record is completed.

Service provider

When completing a service record (as below), please ensure you have carried out the service as described in the manufacturers' instructions. Always use the manufacturers' specified spare parts.

SERVICE/INTERIM WORK ON BOILER <small>delete as appropriate</small>					Date:
Engineer name:		Company name:			
Telephone N°:		Gas Safe registration N°:			
Max rate	CO	ppm	CO ₂	%	CO/CO ₂
Min rate	CO	ppm	CO ₂	%	CO/CO ₂
Where possible, has a flue integrity check been undertaken in accordance with manufacturers' instructions, and readings are correct?"					yes
Gas rate:	m ³ /h	OR	ft ³ /h		
Were parts fitted? <small>delete as appropriate</small>		Yes	No		
Parts fitted:					
System inhibitor concentration has been checked and appropriate action taken, in accordance with BS 7593 and boiler manufacturers' instructions. *					yes n/a
Comments:					
Signature:					

*A System inhibitor efficacy test is required on every annual service in accordance with the manufacturers' instructions and BS 7593. It is only acceptable to not have undertaken this if the service engineers attendance visit was in between annual services to attend a non-water facing component.

SERVICE/INTERIM WORK ON BOILER <small>delete as appropriate</small>					Date:
Engineer name:		Company name:			
Telephone N°:		Gas Safe registration N°:			
Max rate	CO	ppm	CO ₂	%	CO/CO ₂
Min rate	CO	ppm	CO ₂	%	CO/CO ₂
Where possible, has a flue integrity check been undertaken in accordance with manufacturers' instructions, and readings are correct?"					yes
Gas rate:	m ³ /h	OR	ft ³ /h		
Were parts fitted? <small>delete as appropriate</small>		Yes	No		
Parts fitted:					
System inhibitor concentration has been checked and appropriate action taken, in accordance with BS 7593 and boiler manufacturers' instructions. *					yes n/a
Comments:					
Signature:					

*A System inhibitor efficacy test is required on every annual service in accordance with the manufacturers' instructions and BS 7593. It is only acceptable to not have undertaken this if the service engineers attendance visit was in between annual services to attend a non-water facing component.

SERVICE/INTERIM WORK ON BOILER <small>delete as appropriate</small>					Date:
Engineer name:		Company name:			
Telephone N°:		Gas Safe registration N°:			
Max rate	CO	ppm	CO ₂	%	CO/CO ₂
Min rate	CO	ppm	CO ₂	%	CO/CO ₂
Where possible, has a flue integrity check been undertaken in accordance with manufacturers' instructions, and readings are correct?"					yes
Gas rate:	m ³ /h	OR	ft ³ /h		
Were parts fitted? <small>delete as appropriate</small>		Yes	No		
Parts fitted:					
System inhibitor concentration has been checked and appropriate action taken, in accordance with BS 7593 and boiler manufacturers' instructions. *					yes n/a
Comments:					
Signature:					

*A System inhibitor efficacy test is required on every annual service in accordance with the manufacturers' instructions and BS 7593. It is only acceptable to not have undertaken this if the service engineers attendance visit was in between annual services to attend a non-water facing component.

SERVICE/INTERIM WORK ON BOILER <small>delete as appropriate</small>					Date:
Engineer name:		Company name:			
Telephone N°:		Gas Safe registration N°:			
Max rate	CO	ppm	CO ₂	%	CO/CO ₂
Min rate	CO	ppm	CO ₂	%	CO/CO ₂
Where possible, has a flue integrity check been undertaken in accordance with manufacturers' instructions, and readings are correct?"					yes
Gas rate:	m ³ /h	OR	ft ³ /h		
Were parts fitted? <small>delete as appropriate</small>		Yes	No		
Parts fitted:					
System inhibitor concentration has been checked and appropriate action taken, in accordance with BS 7593 and boiler manufacturers' instructions. *					yes n/a
Comments:					
Signature:					

*A System inhibitor efficacy test is required on every annual service in accordance with the manufacturers' instructions and BS 7593. It is only acceptable to not have undertaken this if the service engineers attendance visit was in between annual services to attend a non-water facing component.

SERVICE/INTERIM WORK ON BOILER <small>delete as appropriate</small>					Date:
Engineer name:		Company name:			
Telephone N°:		Gas Safe registration N°:			
Max rate	CO	ppm	CO ₂	%	CO/CO ₂
Min rate	CO	ppm	CO ₂	%	CO/CO ₂
Where possible, has a flue integrity check been undertaken in accordance with manufacturers' instructions, and readings are correct?"					yes
Gas rate:	m ³ /h	OR	ft ³ /h		
Were parts fitted? <small>delete as appropriate</small>		Yes	No		
Parts fitted:					
System inhibitor concentration has been checked and appropriate action taken, in accordance with BS 7593 and boiler manufacturers' instructions. *					yes n/a
Comments:					
Signature:					

*A System inhibitor efficacy test is required on every annual service in accordance with the manufacturers' instructions and BS 7593. It is only acceptable to not have undertaken this if the service engineers attendance visit was in between annual services to attend a non-water facing component.

SERVICE/INTERIM WORK ON BOILER <small>delete as appropriate</small>					Date:
Engineer name:		Company name:			
Telephone N°:		Gas Safe registration N°:			
Max rate	CO	ppm	CO ₂	%	CO/CO ₂
Min rate	CO	ppm	CO ₂	%	CO/CO ₂
Where possible, has a flue integrity check been undertaken in accordance with manufacturers' instructions, and readings are correct?"					yes
Gas rate:	m ³ /h	OR	ft ³ /h		
Were parts fitted? <small>delete as appropriate</small>		Yes	No		
Parts fitted:					
System inhibitor concentration has been checked and appropriate action taken, in accordance with BS 7593 and boiler manufacturers' instructions. *					yes n/a
Comments:					
Signature:					

*A System inhibitor efficacy test is required on every annual service in accordance with the manufacturers' instructions and BS 7593. It is only acceptable to not have undertaken this if the service engineers attendance visit was in between annual services to attend a non-water facing component.

* All installations in England and Wales must be notified to Local Authority Building Control (LABC) either directly or through a Competent Persons Scheme. A Building Regulations Compliance Certificate will then be issued to the customer.

© Heating and Hotwater Industry Council (HHIC)



www.centralheating.co.uk



Cod. 20208493 - 06/24 - Ed. 2

Registered address:

Vokèra Ltd
Borderlake House
Unit 7 Riverside Industrial Estate
London Colney
Herts AL2 1HG

www.vokera.co.uk
www.vokera.ie

Sales, General Enquires

T 0330 236 8630

Vokèra Ireland
West Court, Callan
Co Kilkenny
T 056 7755055

Vokèra Limited reserve the right to change
specification without prior notice
Consumers statutory rights are not affected.

Company Reg No: 1047779