

# PINNACLE

High efficiency system boiler

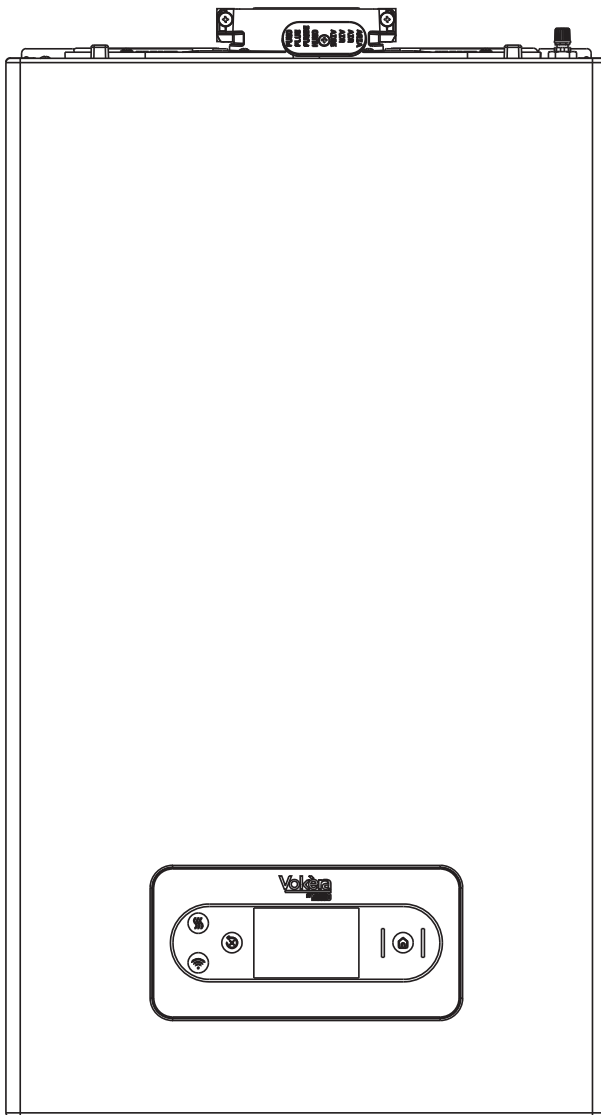

## Users Instructions

## Installation & Servicing Instructions



PINNACLE 20S NG G.C. N° 47-364-25

PINNACLE 25S NG G.C. N° 47-364-26

PINNACLE 32S NG G.C. N° 47-364-27

THESE INSTRUCTIONS  
TO BE RETAINED  
BY USER



Vokèra is a licensed member of the Benchmark scheme which aims to improve the standards of installation and commissioning of domestic hot water systems in the UK.

1. THINGS YOU SHOULD KNOW.....	3	SECTION 6 - MAINTENANCE AND CLEANING .....	30
2. GETTING STARTED.....	3	SECTION 7 - PASSWORD SETTING FOR ACCESSING AND CHANGING PARAMETERS IN THE TECHNICAL MENU .....	32
3. CONTROL PANEL.....	4	SECTION 8 - USER INSTRUCTIONS .....	36
4. HOW TO.....	8	SECTION 9 - GUIDED TOUR .....	39
5. WHAT IF.....	8	SECTION 10 - SERVICING INSTRUCTIONS .....	40
SECTION 1 - DESIGN PRINCIPLES AND OPERATING SEQUENCE .....	10	SECTION 11 - CHECKS, ADJUSTMENTS AND FAULT FINDING ..	41
SECTION 2 - TECHNICAL DATA .....	11	SECTION 12 - LPG INSTRUCTIONS .....	44
SECTION 3 - GENERAL REQUIREMENTS (UK) .....	14	Commissioning checklist .....	45
SECTION 3A - GENERAL REQUIREMENTS (EIRE).....	16	Benchmark .....	46-49
SECTION 4 - INSTALLATION .....	17		
SECTION 5 - COMMISSIONING & OPERATION.....	23		

# USERS INSTRUCTIONS

## INTRODUCTION

### Dear Customer

Your Vokèra **PINNACLE** boiler has been designed to meet and exceed the very latest standards in gas central heating technology, and if cared for, will give years of reliable use and efficiency.

Please therefore take some time to read these instructions carefully.

### Do's and Don't's

- **Do** ensure that the system pressure is periodically checked
- **Do** ensure that the boiler should not be used by children or unassisted disabled people
- **Do** ensure that you know how to isolate the appliance in an emergency
- **Do** ensure that you are familiar with the appliance controls
- **Do** ensure that your installer has completed the appliance log book section
- **Do not** attempt to remove the appliance casing or gain internal access
- **Do not** hang clothes etc. over the appliance
- **Do not** forget to have the appliance serviced annually.

This booklet is an integral part of the appliance. It is therefore necessary to ensure that the booklet is handed to the person responsible for the property in which the appliance is located/installed. A replacement copy can be obtained from the Vokera website

**For the warranty terms and conditions please refer to [www.vokera.co.uk](http://www.vokera.co.uk) (UK) or [www.vokera.ie](http://www.vokera.ie) (ROI).**



At the end of its life, the product should be not be disposed of as solid urban waste, but rather it should be handed over to a differentiated waste collection centre.

## 1. THINGS YOU SHOULD KNOW

### 1.1 GAS APPLIANCES

#### Gas Safety (Installation and Use) Regulation (UK).

In the interests of your safety and that of others it is a legal requirement that all gas appliances are installed and correctly maintained by a competent person and in accordance with the latest regulations.

### 1.2 ELECTRICAL SUPPLY

Please ensure that this appliance has been properly connected to the electrical supply by means of a double pole isolator, and that the correct size of fuse (3 AMP) has been fitted.

**Warning: this appliance must be earthed!**

### 1.3 WARRANTY REGISTRATION

Please take the time to register the appliance warranty which can be done via the Vokera websites - Vokera.co.uk (UK) & Vokera.ie (Ireland) (please have your appliance warranty card to hand).

### 1.4 APPLIANCE COMMISSIONING CHECKLIST (UK only)

The Benchmark checklist section can be found at the rear of the appliance installation booklet. This important document must be completed during the installation/commissioning of your boiler. All GAS SAFE registered installers carry a GAS SAFE ID card, and have a registration number. These details should be recorded in the Benchmark commissioning checklist section within the installation booklet. You can check your installers details by calling GAS SAFE direct on 08004085500. Failure to install and commission the appliance in accordance with the manufacturers instructions will invalidate the warranty. This does not affect your statutory rights.

### 1.5 HOW DOES IT WORK?

Your **PINNACLE** boiler supplies heated water to your radiators and hot water cylinder. The central heating is controlled via a time clock and any thermostats that your installer may have fitted. The boiler will light when it receives a request from the time clock via any thermostat that may be installed. Your **PINNACLE** boiler lights electronically and does not have a pilot light. In the unlikely event of a fault developing with your boiler, the supply of gas to the burner will be terminated automatically.

### 1.6 DIMENSIONS

	HEIGHT	WIDTH	DEPTH
<b>20S-25S-32S</b>	740 mm	420 mm	275 mm

### 1.7 CLEARANCES REQUIRED

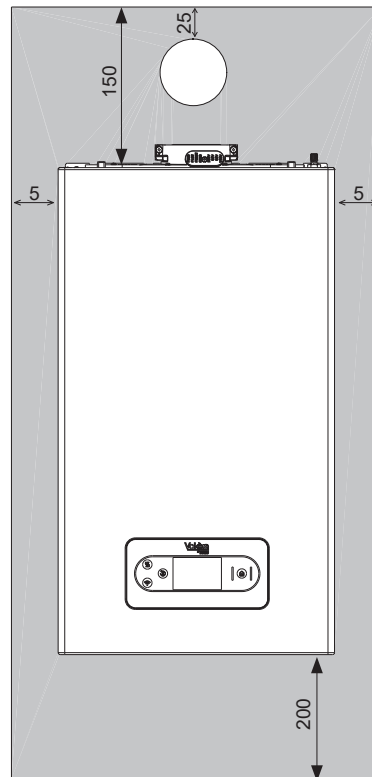

ABOVE	25mm*
BELOW	200mm <sup>^</sup>
LEFT SIDE	5mm
RIGHT SIDE	5mm**
FRONT	4mm***

\* 25mm above flue bend if top flue outlet is used. Consideration should be given to providing reasonable clearance for the insertion of a FGA probe.

\*\* Disconnection of adjacent components may be required in order to facilitate syphon removal.

\*\*\* Provided that a door or removal panel enables 420mm access for maintenance.

<sup>^</sup> Can be reduced to 5mm if a removal panel enables 200mm for maintenance.

## 2. GETTING STARTED

### 2.1 BEFORE SWITCHING ON

Before switching the appliance on, please familiarise yourself with:

- how to isolate the appliance from the gas, water, and electricity supplies;
- how to check and top-up – if necessary – the system water pressure;
- any external thermostats and their functions;
- the appliance controls.

### 2.2 APPLIANCE CONTROLS (see page 2)

**NOTE:** the appliance frost protection is active in all the boiler modes.

The **control panel functions** can be used to vary the temperature of the water that circulates around your radiators and the water that flows from your hot water cylinder. The heating temperature range can be adjusted between 20C - 40C (low temperature) or 40C - 80C (high temperature) this range is configured by your installer and the default is the high temperature range. Refer to the main appliance status table for fault indicator and boiler status.

### 2.3 LIGHTING THE BOILER

**Ensure the gas and electrical supply to the boiler are turned on.** After completing all operations required to prepare commissioning, proceed as follows to start the boiler.

### 2.4 START SCREEN

When the appliance is first connected to the electrical supply, the UI may require you to set the time and date (see page 4), and the appliance will enter its 'pre-purge' mode that will last for several minutes. On completion of the 'pre-purge' phase, the appliance will enter its 'standby' mode unless a heating request has been made. By pressing in the centre of the display it is possible to activate the desired selection (OFF, WINTER).

### 2.5 HOW TO RESET THE APPLIANCE

#### Reset function

In order to reset the boiler's operation in the event of a fault, refer to the adjacent pages for information on the meaning of the various alarm or fault codes; and how to carry out a reset.

### 3. CONTROL PANEL

The **PINNACLE** touchscreen display allows the user to interact quickly and easily with the interface, which, depending on the level of use, is presented with graphic symbols or descriptive text. When the display is not being used, the stand-by screen is shown, simply press in the centre of the display to activate the operating mode.

Key : allows a reset of an ongoing fault.

Key : ENABLE/DISABLE winter operation.

The touchscreen has colours that help the user take even more advantage of the SMART features of our interface:

grey	white	green	red	orange
The colour 'grey' is usually associated with a parameter or function that cannot be changed.	The colour 'white' is usually associated with a parameter or function that can be changed.	Indicates correct operation of the appliance.	When associated with the  symbol it indicates the presence of a fault that sends the boiler into a lockout conditions.	Indicates the presence of a transient fault.

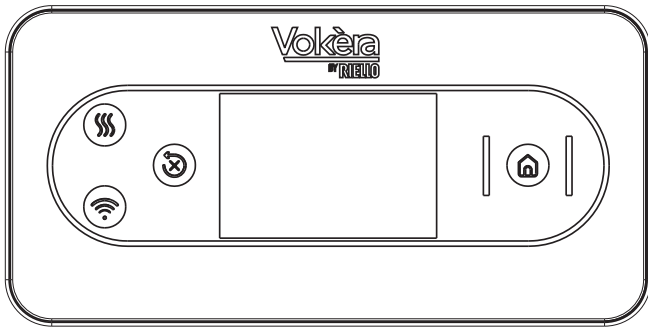

EXAMPLE: WINTER SCREEN - EXAMPLES OF COLORS ON TOUCH SCREEN

WHITE	12	1.2 bar	45.5 °C	52.5 °C
GREY	Gio 14 JUL	12°	42.5°	49.5°
RED				

 Some icons may be active depending on which settings are currently active.

TIME & DATE

FAULT RESET SCREEN

SETTINGS MENU

SETTINGS HEATING DELIVERY TEMPERATURE

SETTINGS DHW TEMPERATURE

COMFORT FUNCTIONS

PRESSURE MANAGEMENT

PRESSURE MANAGEMENT MENU

## USER MENU

12	Menu	1.2 bar
39	Domestic water	52°C
Gio	Heating circuit	45°C
14	Boiler mode	Winter
JUL	System info	
12°C		
12	Menu	1.2 bar
39	Comfort functions	
Gio	Preheat	
14	Biberon	Off
JUL	Guided tour	On/active
12°C	Hourly scheduling	On
12	Menu	1.2 bar
39	Time and date	12:39 thu 14 jul
Gio	Screen lock	Off
14	Buzzer	On/active
JUL	Language	English
12°C		
12	Menu	1.2 bar
39	Technical menu	Blocked
Gio		
14		
JUL		
12°C		

## TECHNICAL MENU

12	Security password	1.2 bar
39	0 0 0 0	
Gio		
14		
JUL		
12°C		

12	Service menu	1.2 bar
39	Chimney sweep	
Gio	Ip	
14	Alarm history	
JUL	Call service	Call service
12°C	High efficiency enable	Not active
	Contact service	

12	Technical menu	1.2 bar
39	Guided tour	
Gio	Combustion	
14	Configuration	
JUL	Heating	
12°C	Dhw	
12	Technical menu	1.2 bar
39	Service	
Gio	Connectivity	
14		
JUL		
12°C		

12	Connectivity	1.2 bar
39	Bus 485 config	
Gio	Wi-Fi key	
14	Ot config	Activate
JUL		
12°C		

12	Combustion	1.2 bar
39	Gas - gas type	
Gio	Methane	
14	D52 - p1 GAS VALVE	45
JUL	Gac	
12°C	Api - power	25 kW

12	Configuration	1.2 bar
39	Hydraulic configuration	
Gio	Inst flowmeter	
14	Min rpm	1000 RPM
JUL	Max rpm	7900 RPM
12°C	Max ch rpm	6300 RPM

12	Configuration	1.2 bar
39	Range rated	6300 RPM
Gio	Config aux 1	Not set
14	Exhaust probe reset	
JUL		
12°C		

12	Configuration	1.2 bar
39	Hydraulic configuration	
Gio	Inst flowmeter	
14	Water pressure transducer	Water transducer
JUL	Auto-fill enable	Not active
12°C	Air purging cycle	

12	Configuration	1.2 bar
39	Min rpm	1000 RPM
Gio	Max rpm	7900 RPM
14	Max ch rpm	6300 RPM
JUL	Range rated	6300 RPM
12°C		

12	Configuration	1.2 bar
39	Config aux 1	Not set
Gio	Exhaust probe reset	
14		
JUL		
12°C		

12	Heating	1.2 bar
39	Pump control type	85
Gio	Ot cascade control	Activate
14	Screed function	
JUL	Anti cycle function	3Min
12°C	Reset ch timers	Activate

12	Heating	1.2 bar
39	Type of heating	High temperature
Gio	Max temp	80.5°C
14	Min temp	40°C
JUL	Thermoregulation	Activate
12°C	Hourly scheduling	Activate

12	Heating	1.2 bar
39	Hyst on high temp	5°C
Gio	Hyst off high temp	5°C
14	Hyst on low temp	3°C
JUL	Hyst off low temp	3°C
12°C	Pump control type	85

12	Heating	1.2 bar
39	Ot cascade control	Activate
Gio	Screed function	
14	Anti cycle function	3Min
JUL	Reset ch timers	Activate
12°C	Type of heating	High temperature

12	Heating	1.2 bar
39	Max temp	80.5°C
Gio	Min temp	40°C
14	Thermoregulation	Activate
JUL	Hourly scheduling	Activate
12°C		



12	Dhw	1.2 bar
39	Anti legionella function	Not active
Gio	Tank hysteresis on	5°C
14	Tank hysteresis off	5°C
JUL	Tank flow temp	80°C
12°C		

12	Dhw	1.2 bar
39	Min temp	37°C
Gio	Max temp	60°C
14	Special functions	None
JUL		
12°C		

12	Dhw	1.2 bar
39	Anti legionella function	Not active
Gio	Tank hysteresis on	5°C
14	Tank hysteresis off	5°C
JUL	Tank flow temp	80°C
12°C		

12	Dhw	1.2 bar
39	Min temp	37°C
Gio	Max temp	60°C
14	Special functions	None
JUL	Post circulation	Not active
12°C		

### 3.1 Signalling and faults

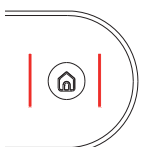
DISPLAY WITH REGULAR OPERATION	GREEN	
		
DISPLAY WITH A FAULT PRESENT	ORANGE	RED
		

The presence of a fault is indicated with two different colours:

- orange: indicates that a self-resetting transient error is present which could limit the correct operation of the boiler
- red (together with the symbol ) indicates the presence of an error which will put the boiler into a lockout condition.

#### Reset function

To restore operation of the boiler in the event of a fault, press . At this point, if the correct operating conditions have been restored, the boiler will restart automatically. A maximum of 5 consecutive unlocking attempts can be made from the interface, after which the interface displays

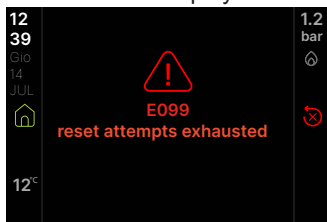

In this case, the boiler must be disconnected from the electricity supply and then reconnected again, to reactivate operation.

 If the attempts to reset the boiler do not work, contact the Technical Assistance Centre.

#### PRESSURE fault

When the pressure value falls below 0.5 bar, the following situations can occur:

##### warning signal FIL

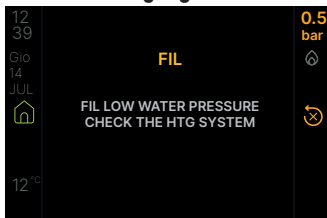

The boiler is operating normally, but it is still recommended to fill the system in the following way:

- attach the temporary flexi-pipe and open both filling taps **A&B**
- close the filling valve, access the Info menu (section 7.2, item I018) to check that the pressure value reaches 1-1.5 bar
- close both **A&B** taps and remove the flexi-pipe (see also "4.1 HOW TO TOP-UP THE SYSTEM PRESSURE" page 8).

#### temporary fault - E041

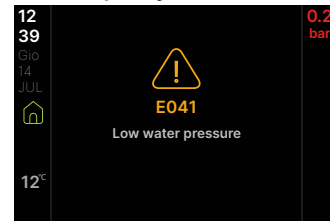

The boiler is not working properly. Fill the system as described in the previous point; operation required within 10 minutes of the message appearing otherwise the anomaly becomes definitive (E040).

#### definitive fault - E040

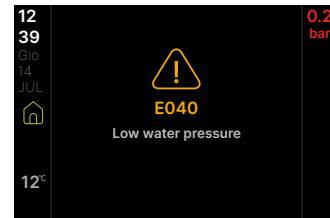

In the event of a permanent lockout, fill the system and then release the alarm.

Press  to restore operation.

Once operation is restored, the boiler performs an automatic vent cycle.

 If the drop in pressure is very frequent, request the intervention of the Technical Assistance Centre.

#### DHW PROBE fault (E060)

Indicates a possible configuration error; please contact Vokera Technical or the Service Centre for assistance.

#### PRIMARY HEAT-EXCHANGER CLEANING fault (E091)

The boiler has an auto-diagnostic system which, based on the total number of hours in certain operating conditions, can signal the need to clean the primary heat exchanger. Once the cleaning operation has been completed with the cleaning kit supplied as an accessory, it is necessary to reset the total hours meter as follows:

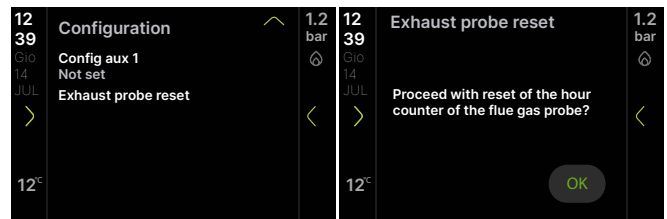

NOTE: The meter resetting procedure should be carried out after each in-depth cleaning of the primary exchanger or if this latter is replaced.

The fault occurs when the hour meter exceeds 2500 hours; this value can be verified as follows:

- access the "System Info" menu to display the value of the flue gas probe meter (display/100, example 2500h = 25).

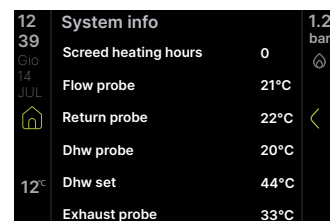

ERROR CODE	ERROR MESSAGE	ERROR TYPE DESCRIPTION	
E010	MAXIMUM NUMBER OF IGNITION ATTEMPTS	DEFINITIVE	
E011	PARASITIC FLAME		
E012	MAXIMUM NUMBER OF FLAME LOSSES		
E013	SERIAL PROTOCOL		
E014	FLAME DETECT TEST FAILED		
E015	VOLTAGE DETECT FLAME TEST FAILED		
E020	LIMIT THERMOSTAT		
E021	GAS VALVE CONTROL MALFUNCTION		
E030	FAN ERROR		
E031	FAN FAILURE MECHANICAL BLOCKAGE		
E032	ROTOR FAN FAILURE BLOCKED		
E033	ROTOR FAN FAILURE DAMAGED		
E034	CHIMNEY OBSTRUCTION IN PREVENTILATION		
E035	BLOCKAGE OBSTRUCTION FLUE GAS LOW POWER		
E036	BLOCKAGE OBSTRUCTION FLUE GAS HIGH POWER		
E037	FAILED COMBUSTION CHECK LOW POWER		
E038	COMBUSTION CHECK FAILED HIGH POWER		
E039	ABNORMAL FLAME VALUE		
E040	LOW WATER PRESSURE		
E042	WATER TRANSDUCER - LWCO ERROR		
E071	HEATING TEMPERATURE OVER LIMIT		
E075	VALVE OPENING LIMIT REACHED		
E081	RETURN TEMPERATURE OVER LIMIT		
E088	CAC FAILED		
E090	EXHAUST PROBE ERROR		
E092	CALIBRATION FAILED		
E093	TOO MANY CALIBRATION ATTEMPTS		
E094	LAMBDA OVER LIMIT		
E097	Check FAILED		
E098	GAC FAILED		
E099	RESET ATTEMPTS EXHAUSTED		
E041	LOW WATER PRESSURE		TRANSITORY
E050	SMOKE OBSTRUCTION ERROR LOW POWER		
E051	SMOKE OBSTRUCTION ERROR HIGH POWER		
E052	HARDWARE ERROR OUT OF THRESHOLD		
E055	NO CARD FAN COMMUNICATION		
E056	NO COMMUNICATION MICROPROCESSOR CARD		
E060	CONFIGURATION ERROR		
E070	CH PROBE ERROR		
E071	HEATING TEMPERATURE OVER LIMIT		
E072	DELTA T RETURN OUT OF LIMIT		
E077	ABSENCE OF COMMUNICATION WITH LOW TEMPERATURE THERMOSTAT		
E080	RETURN PROBE ERROR		
E081	RETURN TEMPERATURE OVER LIMIT		
E082	WARNING DELTA TEMPERATURE		
E090	EXHAUST PROBE ERROR		
E091	CLEAN PRIMARY HT EXCHANGER		
E095	CALIBRATION FAILED		
E096	LAMBDA OVER LIMIT		
FIL	LOW WATER PRESSURE CHECK THE HTG SYSTEM		
pressure value	HIGH WATER PRESSURE CHECK THE HTG SYSTEM	SIGNAL	
COM	APPLIANCE PCB COMMUNICATION LOST (more than 30 seconds)	SIGNAL: (the boiler continues to operate but with no display or keys)	
E065	IMOD ERROR	SIGNAL	
FWER	WARNING FIRMWARE VERSIONS NOT COMPATIBLE	SIGNAL: (the boiler continues to operate but with no display or keys)	
CFS	CALL FOR SERVICE	SIGNAL	
SFS	STOP FOR SERVICE	DEFINITIVE	
OB CD	ON BOARD CLOCK DAMAGED	SIGNAL: (the boiler continues to operate but with no display or keys)	
LLL	GENERIC FIRMWARE BLOCK	SIGNAL	
CFG	GAC NOT EXECUTED	SIGNAL	

## 4. HOW TO...

### 4.1 HOW TO TOP-UP THE SYSTEM PRESSURE

The system pressure must be checked periodically to ensure the correct operation of the boiler. The system pressure is shown at the top of the LCD display or can be read on the gauge located on the underside of the appliance. When the boiler is at room temperature, the system pressure should be approximately 1.0bar. If the pressure requires 'topping-up' use the following instructions as a guide.

- Locate the filling valve connections (usually beneath the boiler, see fig. 1).
- Attach the filling loop to both connections.
- Open the filling valve slowly until you hear water entering the system.
- Close the filling valve when the pressure gauge (on the boiler) reads between 1 and 1.5 BAR.
- Remove the filling loop from the connections.

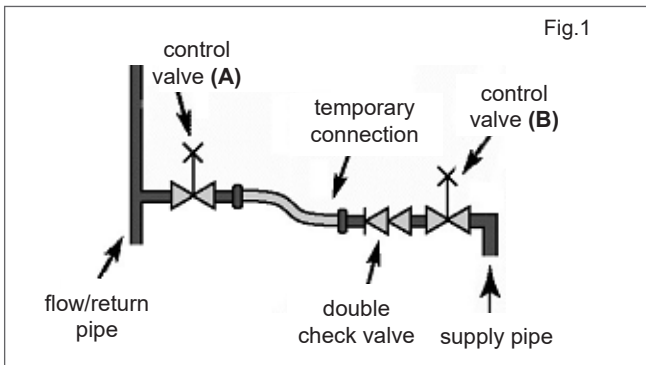

### 4.2 HOW TO CARE FOR THE APPLIANCE

To clean the outer casing use only a clean damp cloth. Do not use any scourers or abrasive cleaners.

## 5. WHAT IF...

### 5.1 WHAT IF I SUSPECT A GAS LEAK

If you suspect a gas leak, turn off the gas supply at the gas meter and contact your installer or local gas supplier. If you require further advice please contact your nearest Vokèra office.

### 5.2 WHAT IF I HAVE FREQUENTLY TO TOP-UP THE SYSTEM

If the system regularly requires topping-up, it may be indicative of a leak. Please contact your installer and ask him to inspect the system.

### 5.3 WHAT IF THE APPLIANCE IS DUE ITS ANNUAL SERVICE

#### Advice for tenants only

Your landlord should arrange for servicing.

#### Advice for homeowners

Please contact Vokèra Customer Service (**0330 236 8630 (UK)** or **056 7755055 (ROI)**) if you would prefer a Vokèra service engineer or agent to service your appliance. Alternatively your local GAS SAFE registered engineer may be able to service the appliance for you.

### 5.4 WHAT IF I NEED TO CALL AN ENGINEER

If you think your boiler may have developed a fault, please contact your installer or Vokèra Customer Services (**0330 236 8630 (UK)** or **056 7755055 (ROI)**) have all your details to hand including full address and postcode, relevant contact numbers, and your appliance log book. It is a requirement of your warranty terms & conditions that your Benchmark logbook has been filled out correctly and is fully up to date.



# INSTALLATION AND SERVICING INSTRUCTIONS

## INTRODUCTION

All installers are asked to follow the Benchmark Scheme by adhering to the Code of Practise, details of which can be obtained from [www.benchmark.org.uk](http://www.benchmark.org.uk).

The **PINNACLE** has aACC (Active Combustion Control) system. This control system ensures functionality, efficiency and low emissions under any conditions.

The ACC system uses an ionisation sensor immersed in the burner flame, whose information allows the control board to operate the gas valve that regulates the fuel.

This sophisticated control system provides the auto-regulation of the combustion, so there is no need for an initial calibration. The ACC system is able to adapt the boiler to operate with different gas compositions, different outlet pipes lengths and different altitudes (within the specified design limits).

The ACC system can also perform an auto-diagnostic operation that locks out the burner before the permitted upper emission limit is exceeded.

The **PINNACLE** product family comprises a range of high-efficiency system boilers. These appliances – by design – incorporate electronic ignition, circulating pump, expansion vessel, safety valve, pressure gauge and automatic by-pass. The range is produced as room sealed, category II2H3P-II2HY203P appliances, suitable for internal wall mounting applications only. Each appliance is provided with a fan powered flue outlet with an annular co-axial combustion air intake that can be rotated – horizontally – through 360 degrees for various horizontal or vertical applications.

These appliances are designed for use with a sealed system only; consequently they are not intended for use on open vented systems.

The boiler is suitable for use with combustible gases group H and/or group E and natural gas mixtures and hydrogen up to 20% by volume.

This booklet is an integral part of the appliance. It is therefore necessary to ensure that the booklet is handed to the person responsible for the property in which the appliance is located/installed. A replacement copy can be downloaded from the Vokera website - [www.vokera.co.uk](http://www.vokera.co.uk).

The boiler complies with basic requirements of the following Directives:

- Regulation (EU) 2016/426;
- Yield directive: Article 7(2) and Annex III of directive 92/42/EEC;
- Electromagnetic compatibility directive 2014/30/EU;
- Low-voltage directive 2014/35/EU;
- Directive 2009/125/EC Ecodesign for energy-using appliances;
- Regulation (EU) 2017/1369 Energy labeling;
- Delegated Regulation (EU) No. 811/2013;
- Delegated Regulation (EU) No. 813/2013;
- Regulation UNI/TS 11854.



**Before connecting the “Hi, Comfort T300 or K100” devices, the Connectivity Menu must be set up correctly to avoid communication failure problems (see section 8.10).**



At the end of its life, the product should not be disposed of as solid urban waste, but rather it should be handed over to a differentiated waste collection and/or recycling centre.

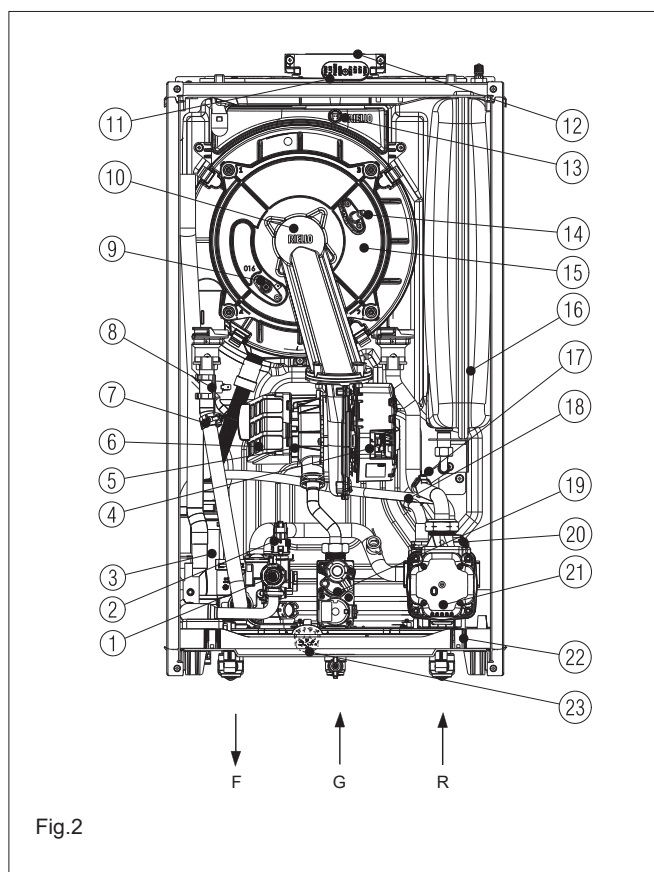

Fig.2

### General layout

- 1 Safety valve
- 2 Pressure transducer
- 3 Siphon
- 4 Fan
- 5 Air filter
- 6 Mixer
- 7 NTC delivery probe
- 8 Limit thermostat
- 9 Flame detection electrode/ionisation sensor
- 10 Burner
- 11 Combustion analysis socket plug
- 12 Flue gas exhaust
- 13 Flue gas probe
- 14 Flame ignition electrode
- 15 Exchanger
- 16 Expansion vessel
- 17 NTC return probe
- 18 Degassing pipe
- 19 Gas valve
- 20 Air vent valve
- 21 Circulator
- 22 Drain tap
- 23 Hydrometer

- R Heating return connection  
 F Heating flow connection  
 G Gas connection

# 1. SECTION - DESIGN PRINCIPLES AND OPERATING SEQUENCE

## 1.1 PRINCIPLE COMPONENTS

- A fully integrated electronic control board featuring electronic temperature control, anti-cycle control, pump over-run, self-diagnostic fault indicator, full air/gas modulation
- Stainless-steel heat exchanger
- Electronic ignition with flame supervision
- Integral high-head pump
- Fan
- Expansion vessel
- Flue sensor
- Pressure transducer
- Safety valve

## 1.2 MODE OF OPERATION (AT REST)

When the appliance is at rest and there are no requests for heating or hot water, the following functions are active:

- frost-protection system: the frost-protection system protects the appliance against the risk of frost damage, if the main temperature falls to 5°C, the appliance will function on minimum power until the temperature on main reaches 35°C.
- anti-block function: the anti-block function enables the pump to be energised for short periods, when the appliance has been inactive for more than 24-hours.

## 1.3 MODE OF OPERATION (HEATING AND/OR HOT WATER)

When there is a request for heat via the onboard clock and/or any external control, the pump and fan are started, the fan speed will modulate until the correct signal voltage is received at the control PCB. At this point an ignition sequence is enabled. Ignition is sensed by the electronic circuit to ensure flame stability at the burner. Once successful ignition has been achieved, the electronic circuitry increases the gas rate to 75% for a period of 15 minutes. Thereafter, the boiler's output will either be increase to maximum or modulate to suit the set requirement. When the appliance reaches the desired temperature the burner will shut down and the boiler will perform a three-minute anti-cycle (timer delay).

When the request for heat has been satisfied the appliance pump and fan may continue to operate to dissipate any residual heat within the appliance.

## 1.4 SAFETY DEVICES

When the appliance is in use, safe operation is ensured by:

- a pressure transducer that monitors system water pressure and will de-activate the pump, fan, and burner should the system water pressure drop below the required minimum value;
- fan speed sensor to ensure safe operation of the burner;
- a high limit thermostat that over-rides the temperature control circuit to prevent or interrupt the operation of the burner;
- flame sensor that will shut down the burner when no flame signal is detected and/or when incomplete combustion or high emissions are detected;
- flue sensor that will shut down the burner if the flue threshold temperature is exceeded;
- a safety valve which releases excess pressure from the primary circuit.

**NOTE:** when the appliance is first switched ON or when the electrical supply is interrupted then restored, the appliance will enter a short 'purge' cycle whereby the pump cycles ON & OFF for approximately 2-minutes. Only when the 'purge' cycle has been completed, will the appliance go through an ignition sequence.

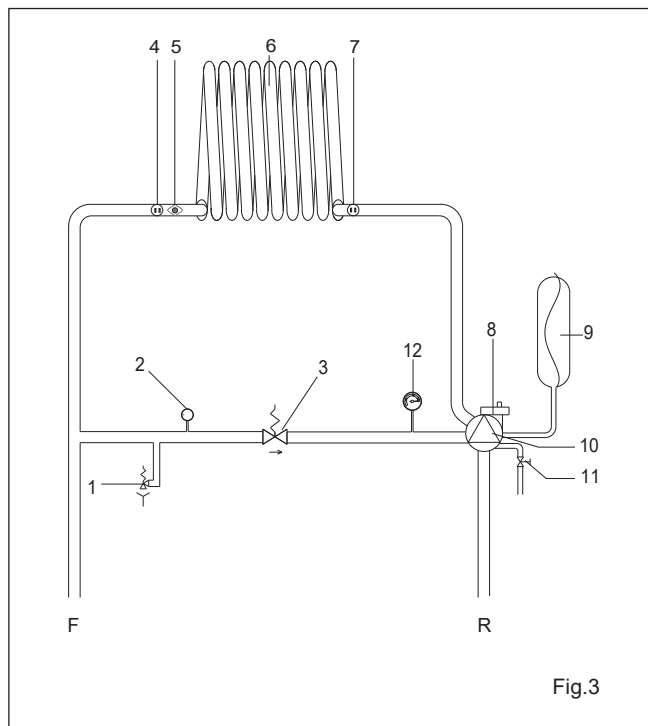

- 1 Safety valve
  - 2 Pressure transducer
  - 3 Automatic by-pass
  - 4 NTC delivery probe
  - 5 Limit thermostat
  - 6 Exchanger
  - 7 NTC return probe
  - 8 Air vent valve
  - 9 Expansion vessel
  - 10 Circulator
  - 11 Drain tap
  - 12 Hydrometer
- R Return connection  
F Flow connection

## 2. SECTION - TECHNICAL DATA

2.1 CENTRAL HEATING	PINNACLE 20S	PINNACLE 25S	PINNACLE 32S
Maximum heat input (kW)	20.00	25.00	32.00
Minimum heat input (kW)	1.90	2.70	2.70
Maximum heat output (kW) 60/80°C	19.53	24.42	31.19
Minimum heat output (kW) 60/80°C	1.77	2.57	2.57
Maximum heat output (kW) 30/50°C	21.31	26.51	33.70
Minimum heat output (kW) 30/50°C	1.96	2.84	2.84
Minimum working pressure	0.25+0.45 bar		
Maximum working pressure	3 bar		
Minimum flow rate	450 l/h		
2.2 GAS PRESSURES	PINNACLE 20S	PINNACLE 25S	PINNACLE 32S
Inlet pressure (G20)	20.0 mbar	20.0 mbar	20.0 mbar
Heating maximum gas rate (m <sup>3</sup> /hr)	2.12	2.64	3.38
Minimum gas rate (m <sup>3</sup> /hr)	0.20	0.29	0.29
2.3 EXPANSION VESSEL	PINNACLE 20S	PINNACLE 25S	PINNACLE 32S
Capacity	9 litres		
Maximum system volume	74 litres		
Pre-charge pressure	1 bar		
2.4 DIMENSIONS	PINNACLE 20S	PINNACLE 25S	PINNACLE 32S
Height (mm)	740		
Width (mm)	420		
Depth (mm)	275		
Dry weight (kg)	28	28	29
2.5 CLEARANCES REQUIRED FOR MAINTENANCE	PINNACLE 20S	PINNACLE 25S	PINNACLE 32S
Sides	5mm*		
Top	150mm** from casing or 25mm above flue elbow (whichever is applicable)**		
Bottom	200mm <sup>^</sup>		
Front	420mm <sup>^^</sup>		
* It may be necessary to remove adjacent components if component removal/replacement is required			
** Consideration should be given to providing reasonable clearance for the insertion of a FGA probe.			
<sup>^</sup> This can be reduced to 4mm if a removal panel enables the required 200mm			
<sup>^^</sup> When installed in a cupboard, this dimension can be reduced to 4mm provided that the required 420mm is available when the door is opened/removed.			
2.6 CONNECTIONS	PINNACLE 20S	PINNACLE 25S	PINNACLE 32S
Flow & return	22mm		
Gas	15mm		
Safety valve	21mm		
Condense	21mm		
2.7 ELECTRICAL	PINNACLE 20S	PINNACLE 25S	PINNACLE 32S
Power consumption CH (Watts)	79	80	104
Voltage (V/Hz)	230/50		
Internal fuse	4 A T (for PCB) - 3.15A F (for connections block)		
External fuse	3A		
2.8 FLUE DETAILS (CONCENTRIC 60-100)	PINNACLE 20S	PINNACLE 25S	PINNACLE 32S
Maximum horizontal flue length (60/100mm)	10.0 m	8.0 m	8.0 m
Maximum vertical flue length (60/100mm)	11.0 m	9.0 m	9.0 m
2.9 EFFICIENCY	PINNACLE 20S	PINNACLE 25S	PINNACLE 32S
SEDBUK 2005 (%)	90.2	90.2	90.1
2.10 EMISSIONS	PINNACLE 20S	PINNACLE 25S	PINNACLE 32S
CO <sub>2</sub> @ maximum output (%) (*)	8.8	8.8	8.8
CO <sub>2</sub> @ minimum output (%) (*)	8.8	8.8	8.8
CO @ maximum output (ppm)	230	200	240
CO @ minimum output (ppm)	15	15	15
NO <sub>x</sub> rating	class 6	class 6	class 6
(*) CO <sub>2</sub> tolerance= +1% -1%			
2.11 FAN ROTATIONS	PINNACLE 20S	PINNACLE 25S	PINNACLE 32S
Maximum number of heating fan rotations (rpm)	6,300	6,200	7,700
Minimum number of heating fan rotations (rpm)	1,000	1,100	1,100
2.12 GAS PRESSURE	PINNACLE 20S	PINNACLE 25S	PINNACLE 32S
Nominal methane gas pressure (G20 - I2H)	20 mbar	20 mbar	20 mbar
Nominal methane-hydrogen gas pressure (G20.2 - I2Y20)	20 mbar	20 mbar	20 mbar
Nominal liquid gas LPG pressure (G31 - I3P)	37 mbar	37 mbar	37 mbar

Parameter	Symbol	20S	25S	32S	Unit
Seasonal space heating energy efficiency class	-	A	A	A	-
Water heating energy efficiency class	-	-	-	-	-
Rated heat output	Pnominal	20	24	31	kW
Seasonal space heating energy efficiency	$\eta_s$	94	94	94	%
<b>Useful heat output</b>					
At rated heat output and high-temperature regime (*)	P4	19.5	24.4	31.2	kW
At 30% of rated heat output and low-temperature regime (**)	P1	6.6	8.2	10.5	kW
<b>Useful efficiency</b>					
At rated heat output and high-temperature regime (*)	$\eta_4$	87.9	87.9	87.8	%
At 30% of rated heat output and low-temperature regime (**)	$\eta_1$	98.8	98.7	98.8	%
<b>Auxiliary electricity consumption</b>					
At full load	elmax	30.0	31.1	54.9	W
At part load	elmin	12.2	13.3	13.6	W
In Stand-by mode	PSB	3.0	3.0	3.0	W
<b>Other parameters</b>					
Stand-by heat loss	Pstby	30.0	35.0	35.0	W
Pilot flame energy consumption	Pign	-	-	-	W
Annual energy consumption	QHE	60	75	96	GJ
Sound power level, indoors	LWA	47	45	48	dB
Emissions of nitrogen oxides	NOx	22	20	35	mg/kWh
<b>For combination heaters</b>					
Declared load profile		-	-	-	
Water heating energy efficiency	$\eta_{wh}$	-	-	-	%
Daily electricity consumption	Qelec	-	-	-	kWh
Daily fuel consumption	Qfuel	-	-	-	kWh
Annual electricity consumption	AEC	-	-	-	kWh
Annual fuel consumption	AFC	-	-	-	GJ

(\*) High-temperature regime means 60 °C return temperature at heater inlet and 80 °C feed temperature at heater outlet

(\*\*) Low temperature means for condensing boilers 30 °C, for low-temperature boilers 37 °C and for other heaters 50 °C return temperature (at heater inlet)

Description	Boiler type PINNACLE S								
	20S	25S	32S	20S	25S	32S	20S	25S	32S
<b>Technical data for typical installations:</b>									
Temperature of combustion products @ Nominal heat output (at 80/60 °C) - [°C]	63	62.2	63.8	63.5	64.2	63.9	49.7	55.2	56.3
Mass flow rate [kg/h] @ Nominal heat output [kW]	2.759	3.158	3.823	2.743	3.365	4.089	2.833	3.2618	3.944
Nominal heat output [kW]	25.8	30.15	35.67	25.55	30.96	38.	26.46	31.02	36.82
Overtemperature of the flue gases [°C]	115								
Temperature of the flue gases at minimum heat output [°C]	35.2	37	39.5	57	58.3	60.1	35.4	36.4	37.4
Mass flow rate [kg/h] @ Minimum heat output [kW]	0.414	0.536	0.694	0.232	0.326	0.422	0.787	0.965	1.187
Minimum heat output [kW]	3.91	5.03	6.52	2.18	3.09	4	7.4	9.02	11.1
CO <sub>2</sub> content @ Nominal heat output [%]	8.42	8.56	8.56	10.00	10.40	10.40	5.62	5.92	5.92
CO <sub>2</sub> at minimum heat output [%]	3.03	3.01	3.04	9.05	9.16	9.26	2.60	2.46	2.56
Loss of minimum permitted pressure (in air feed and flue gas pipe) [Pa]	4.4	8.3	8.3	-	-	-	-	-	-
Loss of maximum permitted pressure (in air supply and flue gas pipe) [Pa]	180	195	195	-	-	-	-	-	-
Maximum permitted pressure difference between combustion air inlet and flue gas outlet (including wind pressure) [Pa]	-	-	-	4.4	8.3	8.3	-	-	-
Maximum permitted combustion air temperature [°C]	-	-	-	45	45	45	-	-	-
<b>C9</b>									
Minimum useful diameter of the flue/vertical technical compartment for combustion air supply [mm]	240								
<b>Notes</b>									
<b>C1:</b> for the installation of the terminals on the wall and roof, refer to the specific instructions contained in the kits the terminals emerge from separate combustion and air supply circuits within a square area of 50 cm									
<b>C3:</b> the terminals of the separate combustion and air supply circuits must lie within a square area of 50 cm, and the distance between the surfaces of the two holes must be less than 50 cm									
<b>C4:</b> the boilers in this configuration, with the relative connection pipes, can be connected to only one natural draught stack condensate flow inside the appliance is not permitted									
<b>C5:</b> the terminals for combustion air supply and the evacuation of flue gases must not be installed on opposite walls of the building									
<b>C6:</b> condensate flow inside the appliance is permitted maximum permitted recirculation rate of 10% in windy conditions the terminals for combustion air supply and the evacuation of flue gases must not be installed on opposite walls of the building.									
⚠ <b>This type of configuration is not permitted in some countries; refer to the local regulations in force</b>									
<b>C8:</b> condensate flow inside the appliance is not permitted									

Fig.4

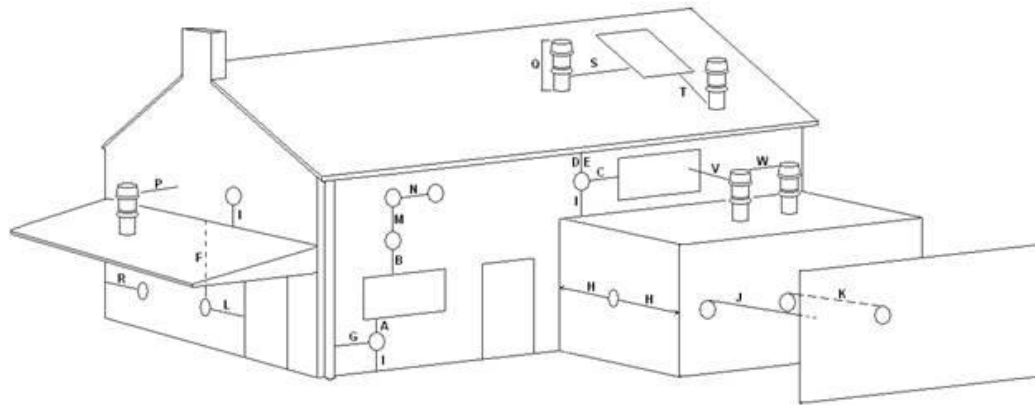

Key	Location	Minimum distance
A	Below an opening (window, air-brick, etc.)	300 mm
B	Above an opening (window, air-brick, etc.)	300 mm
C	To the side of an opening (window, air-brick, etc.)	300 mm
D	Below gutter, drain-pipe, etc.	25 mm
E	Below eaves	25 mm
F	Below balcony, lowest point of carport roof, etc.	25 mm
G	To the side of a soil/drain-pipe, etc.	25 mm (60mm for 80/125mm)
H	From internal/external corner	25 mm (60mm for 80/125mm)
I	Above ground, roof, or balcony level	300 mm
J	From a surface or boundary facing the terminal	600 mm*
K	From a terminal facing a terminal	1200 mm
L	From an opening in the car-port into the building	1200 mm
M	Vertically from a terminal on the same wall	1500 mm
N	Horizontally from a terminal on the same wall	300 mm
P	From a structure to the side of the vertical terminal	300 mm
Q	From the top of the vertical terminal to the roof flashing	As determined by the fixed collar of the vertical terminal
R	To the side of a boundary	300 mm
S	To the side of an opening or window on a pitched roof	600 mm
T	Below an opening or window on a pitched roof	2000 mm
V	From a vertical terminal to an adjacent opening (window, air-brick, etc.)	2000 mm
W	From a vertical terminal to an adjacent vertical terminal	300 mm (only if both terminals are the same height)

\*The possibility that this may be deemed as causing a nuisance, should be considered

### Circulator residual discharge head

The boiler is fitted with a high-efficiency circulator already hydraulically and electrically connected. The relative usable performance values are shown in the chart.

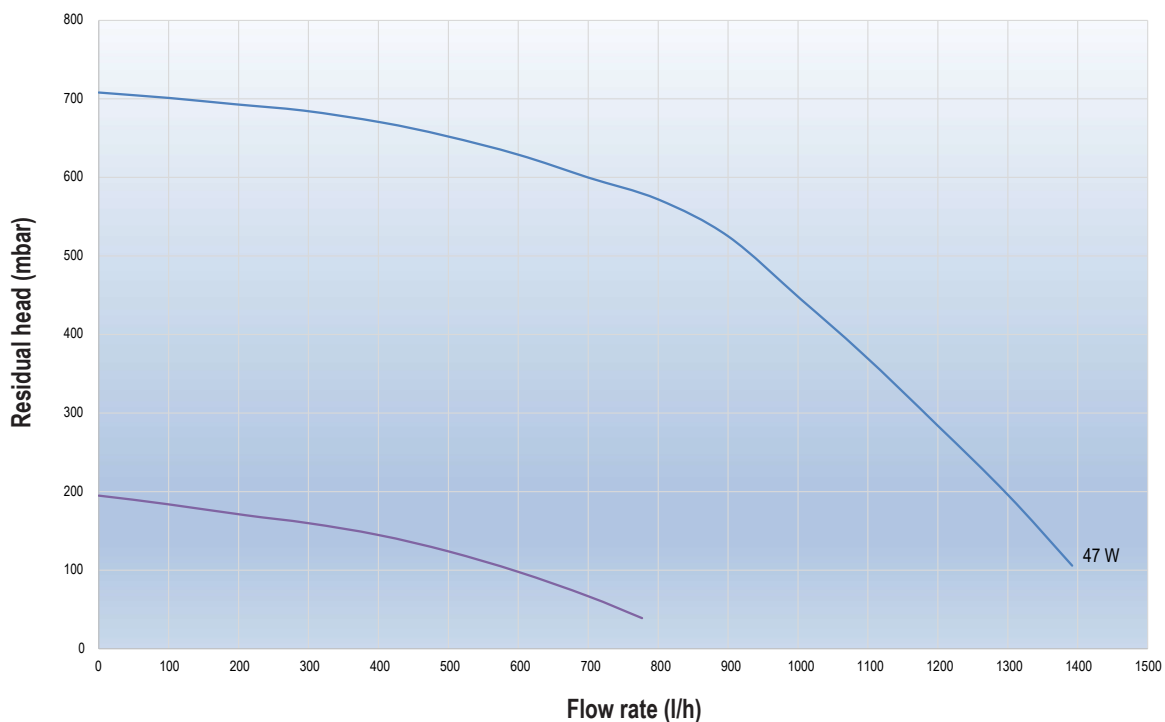

### 3. SECTION - GENERAL REQUIREMENTS (UK)

BS 5440	PART 1	FLUES
BS 5440	PART 2	FLUES & VENTILATION
BS EN 12828		DESIGN FOR WATER-BASED HEATING SYSTEMS
BS 5546		INSTALLATION OF GAS HOT WATER SUPPLIES FOR DOMESTIC PURPOSES
BS 6798		INSTALLATION OF BOILERS OF RATED INPUT NOT EXCEEDING 70kW
BS 6891		LOW PRESSURE INSTALLATION PIPES
BS 7074	PART 1	APPLICATION, SELECTION, AND INSTALLATION OF EXPANSION VESSELS AND ANCILLARY EQUIPMENT FOR SEALED WATER SYSTEM

This appliance must be installed by a competent person in accordance with the Gas Safety (Installation & Use) Regulations.

#### 3.1 RELATED DOCUMENTS

The installation of this boiler must be in accordance with the relevant requirements of the Gas Safety (Installation & Use) Regulations, the local building regulations, the current I.E.E. wiring regulations, the bylaws of the local water undertaking, the Building Standards (Scotland) Regulation, and Building Standards (Northern Ireland) Regulations. It should be in accordance also with any relevant requirements of the local authority and the relevant recommendations of the following British Standard Codes of Practice.

#### ATTENTION

The use of PPE (Personal Protective Equipment) such as but not limited to gloves, mask, safety glasses, etc. is strongly recommended whenever carrying out the installation, repair, or maintenance of this appliance – please pay particular attention to:

- Sharp edges that may be encountered when:- handling or lifting the appliance, removing parts, etc. during installation and maintenance
- Airborne particles that may be released and/or disturbed when cleaning or removing components during maintenance
- Water treatment chemicals that could have been added to the system water may spill from the appliance and or components during maintenance

Please refer to an appropriate Health and Safety document such as HSE L23 (UK) or S.I. 299 (Ireland), for more detailed advice on safe working practices and procedures.

#### 3.2 LOCATION OF APPLIANCE

The appliance may be installed in any room or internal space, although particular attention is drawn to the requirements of the current I.E.E. wiring regulations, and in Scotland, the electrical provisions of the Building Regulations, with respect to the installation of the appliance in a room or internal space containing a bath or shower. When an appliance is installed in a room or internal space containing a bath or shower, the appliance or any control pertaining to it must not be within reach of a person using the bath or shower (refer to IEE regs).

The location chosen for the appliance must permit the provision of a safe and satisfactory flue and termination. The location must also permit an adequate air supply for combustion purposes and an adequate space for servicing and air circulation around the appliance. Where the installation of the appliance will be in an unusual location special procedures may be necessary, BS 6798 gives detailed guidance on this aspect.

A compartment used to enclose the appliance must be designed and constructed specifically for this purpose. An existing compartment/cupboard may be utilised provided that it is modified to suit. Details of essential features of compartment/cupboard design including airing cupboard installations are given in BS 6798. This appliance is not suitable for external installation.

#### 3.3 GAS SUPPLY

The gas meter – as supplied by the gas supplier – must be checked to ensure that it is of adequate size to deal with the maximum rated input of all the appliances that it serves. Installation pipes must be fitted in accordance with BS 6891.

Pipe work from the meter to the appliance must be of adequate size. Pipes of a smaller size than the appliance gas inlet connection must not be used. The installation must be tested for soundness in accordance with BS6891.

If the gas supply serves more than one appliance, it must be ensured that an adequate supply is maintained to each appliance when they are in use at the same time.

**NOTE:** It is recognised that 'pressure loss' through the gas cock and gas valve may result in a pressure drop of approximately 2mbar between the gas meter and gas valve inlet test point; this will not impair the performance of the appliance, provided that a dynamic pressure of 18mbar is available at the appliance inlet.

#### 3.4 FLUE SYSTEM

The terminal should be located where the dispersal of combustion products is not impeded and with due regard for the damage and discoloration that may occur to building products located nearby. The terminal must not be located in a place where it is likely to cause a nuisance (see fig. 4).

In cold and/or humid weather, water vapour will condense on leaving the terminal; the effect of such plumbing must be considered. If installed less than 2m above a pavement or platform to which people have access (including balconies or flat roofs) the terminal must be protected by a guard of durable material. The guard must be fitted centrally over the terminal. Refer to BS 5440 Part 1, when the terminal is 0.5 metres (or less) below plastic guttering or 1 metre (or less) below painted eaves.

#### 3.5 AIR SUPPLY

The following notes are intended for general guidance only. This appliance is a room-sealed, fan-flued boiler, consequently it does not require a permanent air vent for combustion air supply. When installed in a cupboard or compartment, ventilation for cooling purposes is also not required.

#### 3.6 WATER CIRCULATION

Detailed recommendations are given in BS EN 12828 and BS 6798. The following notes are for general guidance only.

##### 3.6.1 PIPEWORK

It is recommended that copper tubing to BS 2871 Part 1 is used in conjunction with soldered capillary joints. Where possible pipes should have a gradient to ensure air is carried naturally to air release points and that water flows naturally to drain cocks. Except where providing useful heat, pipes should be insulated to avoid heat loss and in particular to avoid the possibility of freezing. Particular attention should be paid to pipes passing through ventilated areas such as under floors, loft space, and void areas.

##### 3.6.2 AUTOMATIC BY-PASS

The appliance has a built-in automatic by-pass, consequently there is no requirement for an external by-pass, however the design of the system should be such that it prevents boiler 'cycling'.

##### 3.6.3 DRAIN COCKS

These must be located in accessible positions to facilitate draining of the appliance and all water pipes connected to the appliance. The drain cocks must be manufactured in accordance with BS 2879.

##### 3.6.4 AIR RELEASE POINTS

These must be positioned at the highest points in the system where air is likely to be trapped. They should be used to expel trapped air and allow complete filling of the system.

##### 3.6.5 EXPANSION VESSEL

The appliance has an integral expansion vessel to accommodate the increased volume of water when the system is heated. Refer to the specification table for more detailed information.

##### 3.6.6 FILLING POINT

A method for initial filling of the system and replacing water lost during servicing etc. directly from the mains supply, must be provided (see fig. 5). This method of filling should comply with the current Water Supply (Water Fittings) Regulations 1999 and Water Bylaws 2000 (Scotland).

### 3.6.7 LOW PRESSURE SEALED SYSTEM

An alternative method of filling the system would be from an independent make-up vessel or tank mounted in a position at least 1 metre above the highest point in the system and at least 5 metres above the boiler (see fig. 6).

The cold feed from the make-up vessel or tank must be fitted with an approved non-return valve and stopcock for isolation purposes. The feed pipe should be connected to the return pipe as close to the boiler as possible.

### 3.6.8 FREQUENT FILLING

Frequent filling or venting of the system may be indicative of a leak. Care should be taken during the installation of the appliance to ensure all aspects of the system are capable of withstanding pressures up to at least 3 bar.

### 3.7 ELECTRICAL SUPPLY

The appliance is supplied for operation on 230V @ 50Hz electrical supply; it must be protected with a 3-amp fuse (supplied). The method of connection to the mains electricity supply must allow for complete isolation from the supply. The preferred method is by using a double-pole switch with a contact separation of at least 3mm. The switch must only supply the appliance and its corresponding controls, i.e. time clock, room thermostat, etc.

#### Warning!

This appliance must be earthed.

### 3.8 MOUNTING ON A COMBUSTIBLE SURFACE

The appliance can be mounted on a wall of combustible material without any requirement to fit any additional protective (fire-resistant) material.

### 3.9 TIMBER FRAMED BUILDINGS

If the appliance is to be fitted in a timber framed building, it should be fitted in accordance with the Institute of Gas Engineers publication (IGE/UP/7) 'Guide for Gas Installations in Timber Frame Buildings'.

### 3.10 WATER TREATMENT

Vokera recommend that water treatment be carried out in accordance with the Benchmark Guidance on water treatment in central heating systems. If water treatment products are to be used, then they must be entirely suitable for use with a stainless-steel heat exchanger. Any water treatment product, must be administered in strict accordance with the manufacturer's instructions.

If the appliance is to be installed to an existing system; water treatment and flushing of the complete heating system should be carried out in accordance with BS 7593 and the Benchmark Guidance on water treatment in central heating systems.

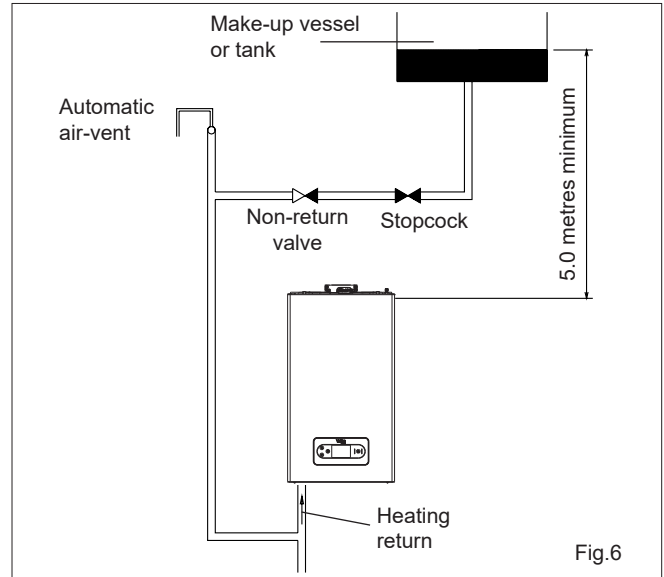
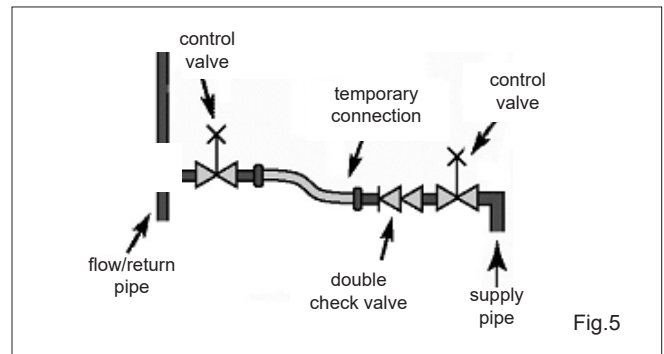

## 3A. SECTION - GENERAL REQUIREMENTS (EIRE)

This appliance must be installed by a competent person in accordance with and defined by, the Standard Specification (Domestic Gas Installations) Declaration (I.S. 813).

### 3A.1 RELATED DOCUMENTS

The installation of this boiler must be in accordance with the relevant requirements of the local building regulations, the current ETCI National Rules for Electrical Installations, and the bylaws of the local water undertaking. It should be in accordance also with any relevant requirements of the local and/or district authority.

#### ATTENTION

The use of PPE (Personal Protective Equipment) such as but not limited to gloves, mask, safety glasses, etc. is strongly recommended whenever carrying out the installation, repair, or maintenance of this appliance – please pay particular attention to:

- Sharp edges that may be encountered when:- handling or lifting the appliance, removing parts, etc. during installation and maintenance
- Airborne particles that may be released and/or disturbed when cleaning or removing components during maintenance
- Water treatment chemicals that could have been added to the system water may spill from the appliance and or components during maintenance

Please refer to an appropriate Health and Safety document such as HSE L23 (UK) or S.I. 299 (Ireland), for more detailed advice on safe working practices and procedures.

### 3A.2 LOCATION OF APPLIANCE

The appliance may be installed in any room or internal space, although particular attention is drawn to the requirements of the current ETCI National Rules for Electrical Installations, and I.S. 813, Annex K. When an appliance is installed in a room or internal space containing a bath or shower, the appliance or any control pertaining to it must not be within reach of a person using the bath or shower. The location chosen for the appliance must permit the provision of a safe and satisfactory flue and termination. The location must also permit an adequate air supply for combustion purposes and an adequate space for servicing and air circulation around the appliance. Where the installation of the appliance will be in an unusual location special procedures may be necessary, refer to I.S. 813 for detailed guidance on this aspect. A compartment used to enclose the appliance must be designed and constructed specifically for this purpose. An existing compartment/cupboard may be utilised provided that it is modified to suit.

This appliance is not configured for external installation.

### 3A.3 GAS SUPPLY

The gas meter – as supplied by the gas supplier – must be checked to ensure that it is of adequate size to deal with the maximum rated input of all the appliances that it serves. Installation pipes must be fitted in accordance with I.S. 813.

Pipe work from the meter to the appliance must be of adequate size. Pipes of a smaller size than the appliance gas inlet connection must not be used. The installation must be tested for soundness in accordance with I.S. 813.

If the gas supply serves more than one appliance, it must be ensured that an adequate supply is maintained to each appliance when they are in use at the same time.

**NOTE:** It is recognised that 'pressure loss' through the gas cock and gas valve may result in a pressure drop of approximately 2mbar between the gas meter and gas valve inlet test point; this will not impair the performance of the appliance, provided that a dynamic pressure of 18mbar is available at the appliance inlet.

### 3A.4 FLUE SYSTEM

The terminal should be located where the dispersal of combustion products is not impeded and with due regard for the damage and discoloration that may occur to building products located nearby. The terminal must not be located in a place where it is likely to cause a nuisance (see I.S. 813).

In cold and/or humid weather, water vapour will condense on leaving the terminal; the effect of such plumbing must be considered.

If installed less than 2m above a pavement or platform to which people have access (including balconies or flat roofs) the terminal must be protected by a guard of durable material. The guard must be fitted centrally over the terminal. Refer to I.S. 813, when the terminal is 0.5 metres (or less) below plastic guttering or 1 metre (or less) below painted eaves.

### 3A.5 AIR SUPPLY

The following notes are intended for general guidance only.

This appliance is a room-sealed, fan-flued boiler, consequently it does not require a permanent air vent for combustion air supply. When installed in a cupboard or compartment, ventilation for cooling purposes is also not required.

### 3A.6 WATER CIRCULATION

Specific recommendations are given in I.S. 813. The following notes are for general guidance only.

#### 3A.6.1 PIPEWORK

It is recommended that copper tubing be used in conjunction with soldered capillary joints. Where possible pipes should have a gradient to ensure air is carried naturally to air release points and that water flows naturally to drain cocks. Except where providing useful heat, pipes should be insulated to avoid heat loss and in particular to avoid the possibility of freezing. Particular attention should be paid to pipes passing through ventilated areas such as under floors, loft space, and void areas.

#### 3A.6.2 AUTOMATIC BY-PASS

The appliance has a built-in automatic by-pass, consequently there is no requirement for an external by-pass, however the design of the system should be such that it prevents boiler 'cycling'.

#### 3A.6.3 DRAIN COCKS

These must be located in accessible positions to facilitate draining of the appliance and all water pipes connected to the appliance.

#### 3A.6.4 AIR RELEASE POINTS

These must be positioned at the highest points in the system where air is likely to be trapped. They should be used to expel trapped air and allow complete filling of the system.

#### 3A.6.5 EXPANSION VESSEL

The appliance has an integral expansion vessel to accommodate the increased volume of water when the system is heated. Refer to the specification table for more detailed information.

#### 3A.6.6 FILLING POINT

A method for initial filling of the system and replacing water lost during servicing etc. must be provided (see fig. 5). You should ensure this method of filling complies with the local water authority regulations.

#### 3A.6.7 LOW PRESSURE SEALED SYSTEM

An alternative method of filling the system would be from an independent make-up vessel or tank mounted in a position at least 1 metre above the highest point in the system and at least 5 metres above the boiler (see fig. 6). The cold feed from the make-up vessel or tank must be fitted with an approved non-return valve and stopcock for isolation purposes. The feed pipe should be connected to the return pipe as close to the boiler as possible.

#### 3A.6.8 FREQUENT FILLING

Frequent filling or venting of the system may be indicative of a leak. Care should be taken during the installation of the appliance to ensure all aspects of the system are capable of withstanding pressures up to at least 3 bar.

### 3A.7 ELECTRICAL SUPPLY

The appliance is supplied for operation on 230V @ 50Hz electrical supply; it must be protected with a 3-amp fuse (supplied). The method of connection to the mains electricity supply must allow for complete isolation from the supply. The preferred method is by using a double-pole switch with a contact separation of at least 3mm. The switch must only supply the appliance and its corresponding controls, i.e. time clock, room thermostat, etc.

#### Warning!

This appliance must be earthed.

### 3A.8 MOUNTING ON A COMBUSTIBLE SURFACE

The appliance can be mounted on a wall of combustible material without any requirement to fit any additional protective (fire-resistant) material.

### 3A.9 TIMBER FRAMED BUILDINGS

If the appliance is to be fitted in a timber framed building, it should be fitted in accordance with I.S. 813 and local Building Regulations. The Institute of Gas Engineers publication (IGE/UP/7) 'Guide for Gas Installations in Timber Frame Buildings' gives specific advice on this type of installation.



### 3A.10 WATER TREATMENT

Vokera recommend that water treatment be carried out in accordance with the Benchmark Guidance on water treatment in central heating systems. If water treatment products are to be used, then they must be entirely suitable for use with a stainless-steel heat exchanger. Any water treatment product, must be administered in strict accordance with the manufacturer's instructions. If the appliance is to be installed to an existing system; water treatment and flushing of the complete heating system should be carried out in accordance with BS 7593 and the Benchmark Guidance on water treatment in central heating systems.

### 3A.11 DECLARATION OF CONFORMITY

A Declaration of Conformity (as defined in I.S. 813) must be provided on completion of the installation. A copy of the declaration must be given to the responsible person and also to the gas supplier if required. This appliance must be installed by a competent person in accordance with and defined by, the Standard Specification (Domestic Gas Installations) Declaration (I.S. 813).

## 4. SECTION - INSTALLATION

### NOTE

Please refer to 3/3A and use the appropriate PPE when carrying out any of the actions or procedures contained within this section.

### 4.1 PREPARATION FOR MOUNTING THE APPLIANCE

The appliance should be mounted on a smooth, vertical surface, which must be capable of supporting the full weight of the appliance. Care should be exercised when determining the position of the appliance with respect to hidden obstructions such as pipes, cables, etc.

When the position of the appliance has been decided – using the template supplied – carefully mark the position of the anchor holes (see Fig. 7) and flue-hole (if applicable).

Ensure that the anchors are securely fixed to support the appliance weight.

Fig.7

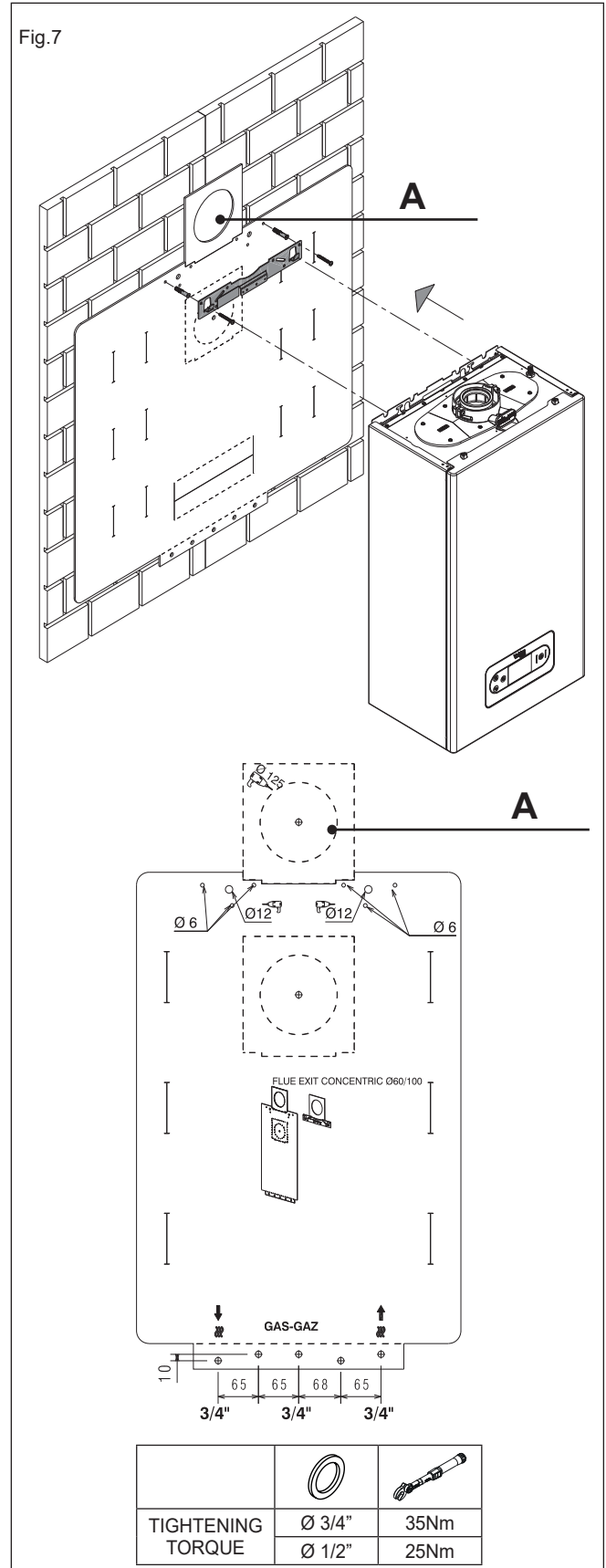

## 4.2 FITTING THE FLUE

This appliance incorporates a 'click-fit' flue connection at the top of the appliance.

**NOTE:** The boiler flue gas exhaust turret is sized for a concentric pipe with an external diameter of the flue gas pipe 60 +0.6 -0.3 mm and an external diameter of the air pipe 100 +0.3 -0.7 mm. Make sure the coupling is watertight.

### 4.2.1 CONCENTRIC HORIZONTAL FLUE

These instructions relate specifically to the installation of this appliance with the Vokera 60/100mm 'X-type' (click-fit) flue terminals accessories. For specific instructions on installing this appliance with an alternative Vokera flue system, e.g. 80/125mm; please refer to the instructions supplied with the specific flue system, or download the instructions from the Vokera website. The appliance flue outlet elbow can be rotated through 360° on its vertical axis. In addition the flue may be extended from the outlet elbow in the horizontal plane. A reduction must also be made to the maximum length (see table below) when additional bends are used.

#### Reduction for additional bends

Bend	Reduction in maximum flue length for each bend
45° bend	1.3 metre
90° bend	1.6 metre

#### Horizontal/Vertical flue terminals and accessories

Part No.	Description	Length/Size
20122759	XF Horizontal 'Click fit' Flue Kit	796mm C/E
20122761	XT Telescopic 'Click fit' Flue Kit	400-575mm C/E
20122763	XV Vertical 'Click fit' Flue Kit	1000mm + VC
20132060	0.5-Metre Extension	500mm
20132061	1.0-Metre Extension	1000mm
20132062	2.0-Metre Extension	2000mm
20132059	90-Degree Bend	N/A
20132058	45-Degree Bend x 2	N/A
20131979	Telescopic Extension	372/519mm
20142842	PMK Plume Kit	1370mm
20142841	45° Plume divertor	N/A
20132050	Pitched Roof Flashing	500mm x 500mm
20135582	Flat Roof Flashing	340mm Dia.
20135587	Wall Brackets	208mm C/E
20121903	Vert. Connector 'Click Fit' VC	131mm

Fig. 7: referring to position **A**, mark and drill a hole for the passage of the flue pipe. Both horizontal terminals (fixed & telescopic) have an eccentric configuration, that enables condense fluid to drain back to the appliance; consequently the terminals should be installed level.

**NOTE:** any horizontal runs that incorporate extensions, must have a 3-degree fall-back to the appliance.

**NOTE:** Minimum horizontal flue length = 0.35m.

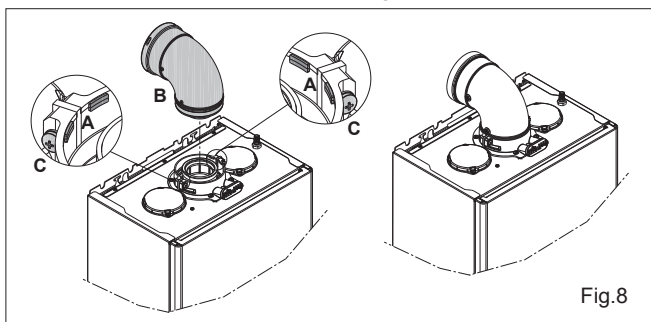

Fig.8

### 4.2.2 FITTING THE HORIZONTAL FLUE KIT

Carefully measure the distance from the centre of the appliance flue outlet to the edge of the finished outside wall (dimension X). Add 65mm to dimension X to give you Dimension Y (see Fig.9). Measure dimension Y from the terminal end of the concentric flue pipe and cut off the excess ensuring any burrs are removed. Pass the concentric flue pipe through the previously drilled hole. Fit the flue bend to the boiler flue outlet and insert the concentric flue pipe into the flue bend ensuring the correct seal is made.

**NOTE (Fig.8):** The appliance incorporates a 'click-fit' flue connection. Ensure that both screws 'C' on the 'click-fit' have been slackened off. Ensure that the connector is correctly aligned with the 'click-fit' and insert it into the 'click-fit' until it clicks into position (this is when the tabs at points 'A' are located in the groove of the flue bend connector). Both screws (C) should now be tightened.

#### NOTE

Fit the internal (white) trim to the flue assembly prior to connecting the flue pipe to the bend.

You must ensure that the entire flue system is properly supported and connected. Seal the flue assembly to the wall using cement or a suitable alternative that will provide satisfactory weatherproofing. The exterior trim can now be fitted.

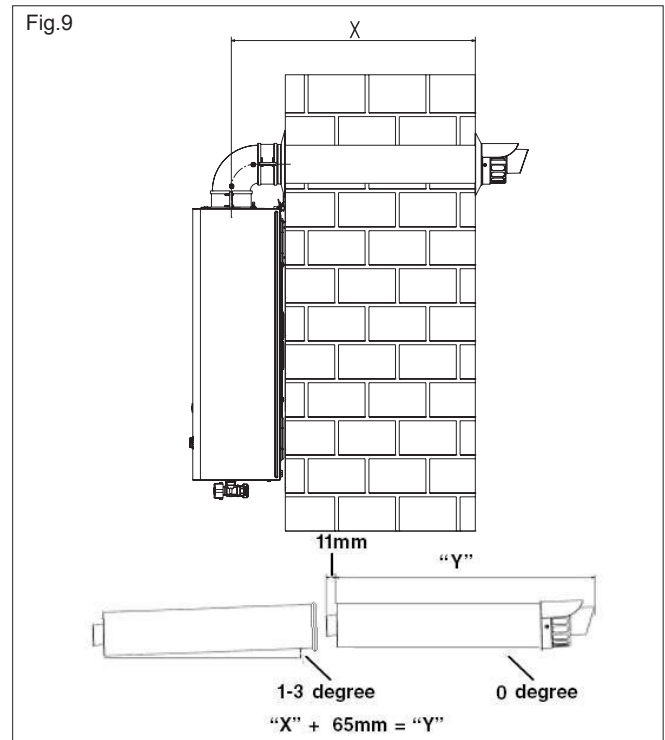
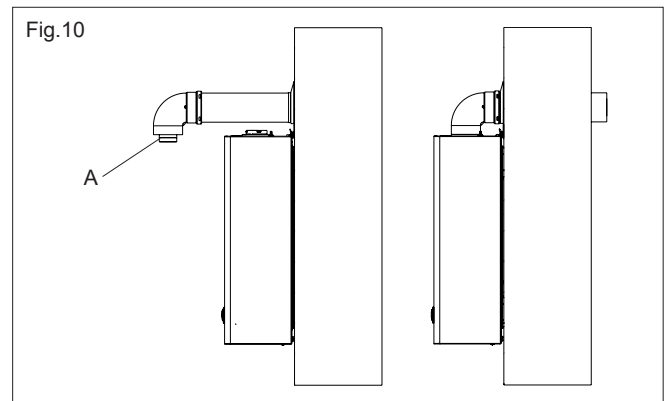

Fig.10



### 4.2.3 EXTENDING THE FLUE

Connect the bend – supplied with the terminal kit – to the top of the boiler (see Fig.8). The additional bends & extensions have push-fit connections, care should be taken to ensure that the correct seal is made when assembling the flue system. Connect the required number of flue extensions or bends (up to the maximum equivalent flue length) to the flue terminal (Fig. 11). The flue system should have a 3° rise from the boiler to outside, to ensure any condense fluid that forms, is allowed to drain back to the appliance.

#### NOTE

When cutting an extension to the required length, you must ensure that the excess is cut from the plain end of the extension (Fig. 11). Remove any burrs, and check that all seals are located properly. You must ensure that the entire flue system is properly supported and connected. Seal the flue assembly to the wall using cement or a suitable alternative that will provide satisfactory weatherproofing. The interior and exterior trim can now be fitted.

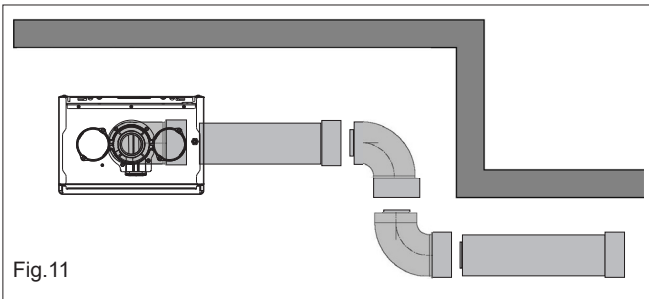

Fig. 11

#### 4.2.4 CONCENTRIC VERTICAL FLUE

Using Fig. 13 as a reference, cut a 110mm diameter hole in the roof and/or ceiling to facilitate the route of the vertical flue system. **NOTE:** ensure that the top of the appliance - if already in position - is covered and protected from the possibility of any dust or debris falling or entering the appliance via the flue outlet.

Fit the appropriate flashing to the roof and insert the vertical flue terminal through the flashing from outside, ensuring that the collar of the terminal is located over the outlet of the flashing.

The fixing holes for the appliance wall mounting bracket should now be drilled and plugged. An appropriate type and quantity of fixing should be used to ensure that the bracket is mounted securely. Once the bracket has been secured to the wall, mount the appliance onto the bracket.

If the vertical flue system requires additional extensions or bends, connect these to the vertical terminal, ensuring the following:

- the maximum permitted flue length is not exceeded
- reductions to the maximum flue length have been made for any bends that are used on the vertical flue system
- any horizontal sections of the flue system, incorporate a 3-degree fallback to the appliance
- the entire flue system is fully supported and secured using the appropriate brackets
- if/when an extension is cut to a shorter length, ensure that the excess length is cut from the plain end of the extension, and that any burrs or rough edges are removed
- all seals are properly located before assembling or connecting the flue system.

**IMPORTANT:** The VX flue terminal is supplied with a sachet of silicone lubricant; smear a small amount of the lubricant around both inner and outer connections, at both ends of the vertical flue connector (supplied with the VX terminal).

**NOTE (Fig. 12):** The appliance incorporates a 'click-fit' flue connection. Ensure that both screws 'C' on the 'click-fit' have been slackened off. Ensure that the connector is correctly aligned with the 'click-fit' and insert it into the 'click-fit' until it clicks into position (this is when the tabs at points 'A' are located in the groove of the vertical flue connector). Both screws (C) should now be tightened.

**NOTE:** If more convenient, the vertical flue connector can be attached to the vertical flue terminal/extension before connecting it to the appliance.

**NOTE:** Minimum length of vertical flue = 2m.

**NOTE:** Additional bends and/or extensions can be connected to the terminal connector if desired, however if additional bends are fitted, a reduction must be made to the maximum flue length (see table below).

#### Reduction for bends

Bend	Reduction in maximum flue length for each bend
45° bend	1.3 metre
90° bend	1.6 metre

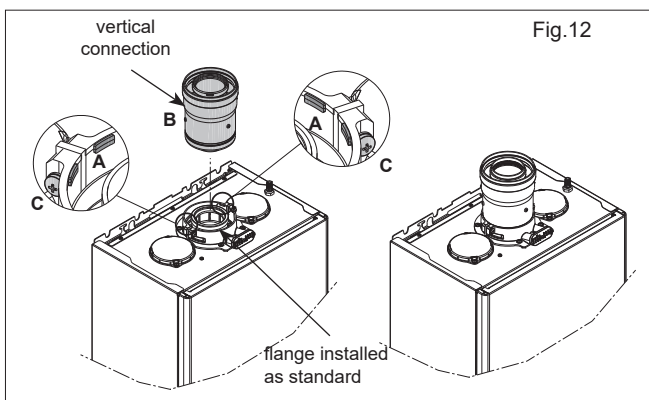

Fig. 12

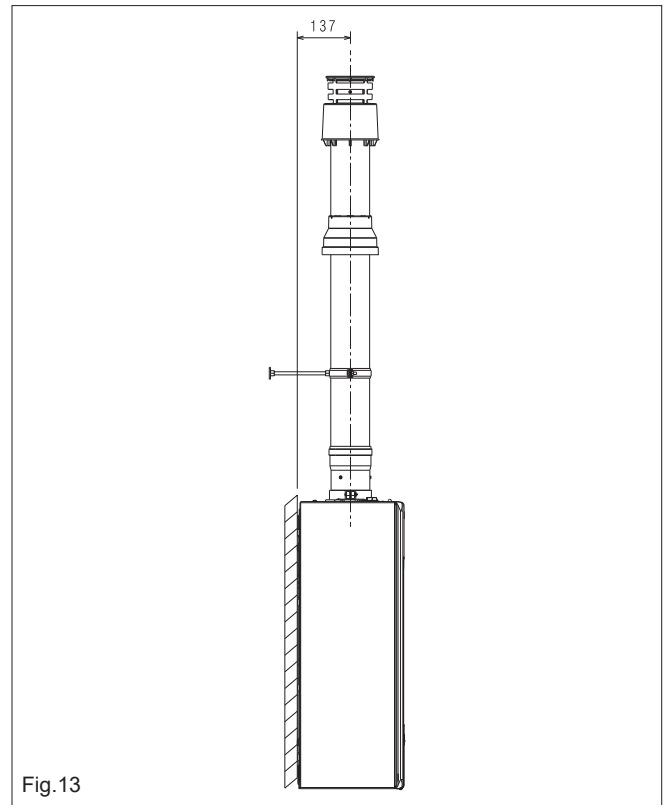

Fig. 13

#### IMPORTANT

The vertical flue terminal is 1.0 metre in length and cannot be cut; therefore it may be necessary to adjust the height of the appliance to suit or use a suitable extension.

#### 4.3 CONNECTING THE GAS & WATER (FIG. 14)

The appliance is supplied with an accessory pack that includes service valves. The service valves are of the compression type. The accessory pack contains sealing washers etc, for use with the service valves. When connecting pipe work to the valves, tighten the compression end first then insert the sealing washers before tightening the valve to the appliance.

**NOTE:** it will be necessary to hold the valve with one spanner whilst tightening with another.

The valves must be fitted perpendicular with the rear of the appliance, in order to avoid obstruction.

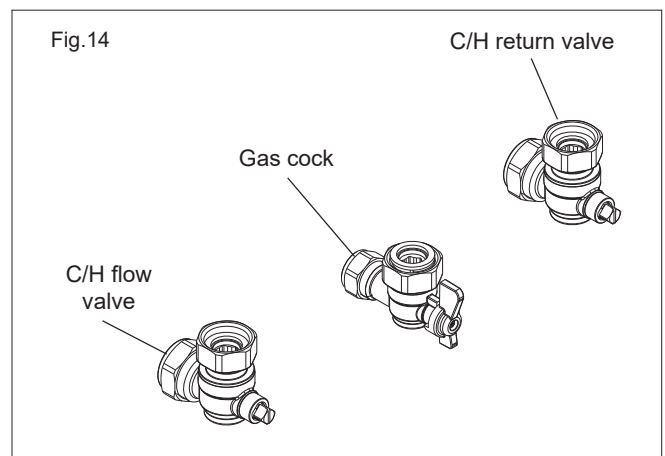

Fig. 14

#### 4.3.1 GAS

The appliance is supplied with a 15mm service valve, connect a 15mm pipe to the inlet of the valve and tighten both nuts.

**NOTE:** it will be necessary to calculate the diameter of the gas supply pipe to ensure the appliance has an adequate supply of gas.

### 4.3.2 FLOW & RETURN

The appliance is supplied with 22mm service valves for the flow and return connections, connect a 22mm pipe to the inlet of each valve and tighten both nuts.

**NOTE:** depending on system requirements, it may necessary to increase the size of the flow & return pipe work after the service valve connections.

### 4.3.3 SAFETY VALVE

The appliance incorporates a combined pressure relief and condensate discharge arrangement. Consequently the combined discharge pipe must have a continuous fall away from the appliance and should be suitably protected against the risk of freezing.

Alternatively it is permissible to fit a tundish, e.g. Mactun, Hotun, etc. close to or adjacent to the discharge pipe where it exits the appliance.

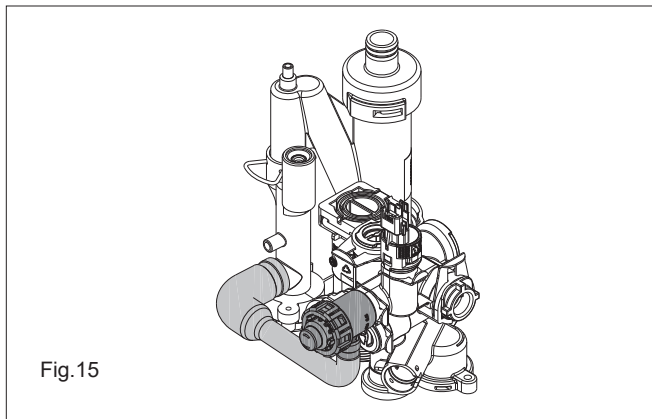

Fig. 15

### 4.3.4 CONDENSE PIPE

This appliance will - under normal operating conditions - produce condensate fluid that will require to be disposed of via the dwelling's waste water drainage system. Vokera strongly recommends that the condensate pipe is connected to the internal waste water pipework in accordance with BS6798.

BS6798 provides comprehensive instruction and advice on all permissible condensate disposal methods; notwithstanding this, it is essential that the following is strictly adhered to:

- use only plastic drainage pipe (minimum OD of 21.5mm)
- horizontal runs must incorporate a minimum 45mm fall per metre, away from the appliance
- external pipework and/or pipework in unheated areas, must have a minimum OD of 32mm and be insulated with Class-O pipe insulation
- the route, type, and termination of the condensate disposal method, must not permit any spillage of condensate fluid, into the dwelling in the event of a blockage or freezing of the condensate pipework
- if there is a risk of freezing, Vokera strongly recommends that a tundish is incorporated within the discharge pipework (see section 4.3.3 above).

Should it not be possible to route and terminate the condensate pipework internally using 'gravity discharge'; Vokera recommends that the Vokera condensate pump (code 404) be considered as an alternative solution.

Ensure that the end-user is aware of the effect/consequences of the condensate pipework becoming blocked or frozen.

### 4.3.5 INSTRUCTION FOR CONDENSATION EXHAUST CONNECTION

**!** All components of the product condensation drain system must be properly maintained in accordance with the manufacturer instructions and cannot be modified in any way.

This product is designed to prevent the escape of gaseous products of combustion through the condensation drain pipe with which it is equipped, this is obtained by using a special siphon placed inside the appliance. The construction of the condensation exhaust system downstream of the appliance is the responsibility of the installer.

The condensation exhaust system must be dimensioned and installed in such a way as to guarantee the correct evacuation of the condensation produced by the appliance and/or collected by the evacuation systems of combustion products. All the components of the condensation exhaust system must be made in a workmanlike manner using materials that are suitable for withstanding the mechanical, thermal and chemical stresses of the condensation produced by the appliance over time. Note: if the condensation exhaust system is exposed to the risk of frost, always provide an adequate level of insulation of the pipe and consider any increase in the diameter of the pipe itself. The condensation exhaust pipe must always have an adequate slope level to prevent the condensation from stagnating and its proper drainage. The condensation exhaust system must have an inspectable disconnection between the condensation exhaust pipe of the appliance and the condensation exhaust system.

### 4.4 ELECTRICAL CONNECTIONS

The boiler is supplied with a short fly-lead. This lead can be used for connection to the electrical supply. Connect the fly-lead to a fused isolator in the following way:

- brown wire to LIVE supply
- blue wire to NEUTRAL supply
- green/yellow to EARTH connection.

Insert the supplied 3-AMP fuse into the fused isolator.

Should the fly-lead be unsuitable, refer to 4.6 for details on how to connect the electrical supply directly to the boiler.

The electrical supply must be as specified in section 3/3A. A qualified electrician should connect the appliance to the electrical supply. If controls - external to the appliance - are required, a competent person must undertake the design of any external electrical circuits, please refer to section 11 for detailed instructions. ANY EXTERNAL CONTROL OR WIRING MUST BE SERVED FROM THE SAME ISOLATOR AS THAT OF THE APPLIANCE. The supply cable from the isolator to the appliance must be 3-core flexible seized 0.75mm to BS 6500 or equivalent. Wiring to the appliance must be rated for operation in contact with surfaces up to 90 °C.

#### NOTE:

- See pages 22 & 43 for wiring of typical external controls into connector CE8.
- Do not connect 230V to any of the CE8 terminals.
- Do not remove the white link wire from TBT unless it's to be used to connect an approved control.

#### MODBUS CONNECTION - CE4

The CE4 connector is located on the underside of the appliance towards the front left.

**!** We recommend using conductors with a section no larger than 0,5 mm<sup>2</sup>.

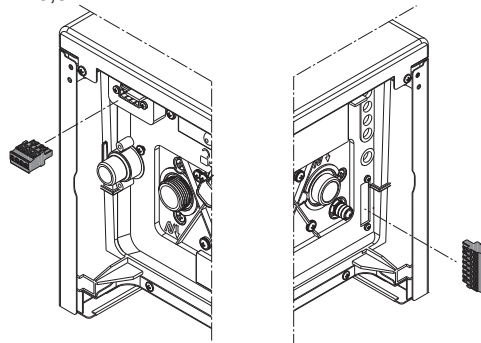

#### CE8 LOW-VOLTAGE CONNECTIONS

The CE8 low-voltage connector is located on the underside of the appliance; at the rear of the right hand side. There are 4-pairs of connectors:

- >TBT - Safety or alarm connector
- >TA - External control (clock, etc.)
- >OT+ - Opentherm
- >SE - External sensor

**NOTE:** when an OT bus remote control is connected to the system, the boiler display shows (see figure on the right):



- Please note that, if OT bus remote control connected:
- it is no longer possible to set the boiler OFF/WINTER status (which can now be set via the OT bus remote control)
  - the heating setpoint value calculated by the OT bus remote control is displayed in the “System Info” screen
  - it is only possible to set the heating setpoint in the boiler if zone valve management is enabled.

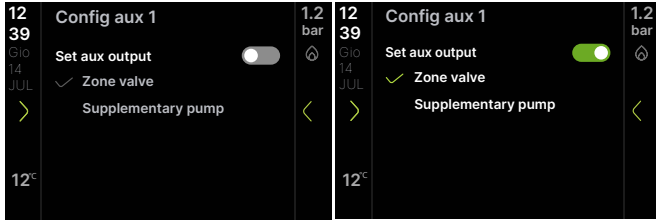

The value can be seen in the “System Info” screen

- to activate the COMBUSTION ANALYSIS, function, with OT bus remote control connected, the connection must be temporarily disabled; remember to restore this connection once the function has completed.

**Alarm reset, INFO displays and settings remain active.**

#### 4.5 CASING REMOVAL

To gain internal access to the appliance you must first remove the front cover, proceed as outlined below:

- locate and unscrew the 2-screws that secure the front cover to the appliance
- Disengage both clips at 1A to release the lower part of the front cover
- lift the cover upward to disengage it from the top locating hooks and then remove
- store the cover and screws safely until required. Re-fit in the reverse order
- press and hold the spring tabs on either side of the control panel where it meets the appliance side panels and gently lower it until it rests.

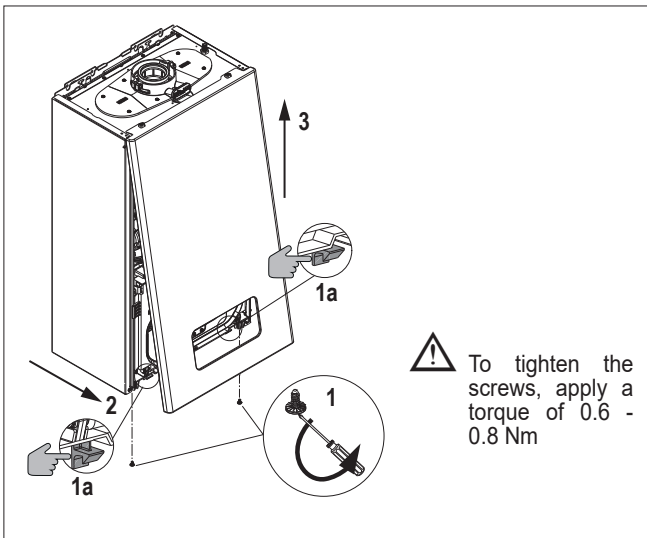

#### 4.6 CONNECTING THE MAINS (230V) INPUT



Unhook and remove the terminal block cover (230V).

Pass the cable through the cable anchorage point. Connect the supply cable wires (LIVE, NEUTRAL, & EARTH) to their corresponding terminals (L, N, & E) on the appliance – high voltage – terminal block (M3). When connecting the EARTH wire, ensure that it's left slightly longer than the others, this will prevent strain on the EARTH wire should the cable become taut. Route the electrical supply via the cable entry/exit point and secure to the sleeve using an appropriate cable tie, and/or silicone sealant.

If it is anticipated that external controls will be required please refer to the wiring diagrams in section 11 for more detailed information.

#### NOTE

It is the installer's responsibility to ensure that the appliance is properly Earthed. Vokèra Ltd. cannot be held responsible for any damages or injuries caused as a result of incorrect Earth wiring.

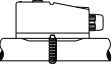
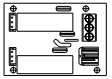
ACCESSORIES		
	X4	L-N antifreeze heaters
	CE8	TA: (room thermostat)
	CE8	OT+
	CE8	SE: outdoor temperature sensor
	CE8	TBT: Low temperature limit thermostat
	X10	Alarm remote control
	X11	Zone valve or additional pump

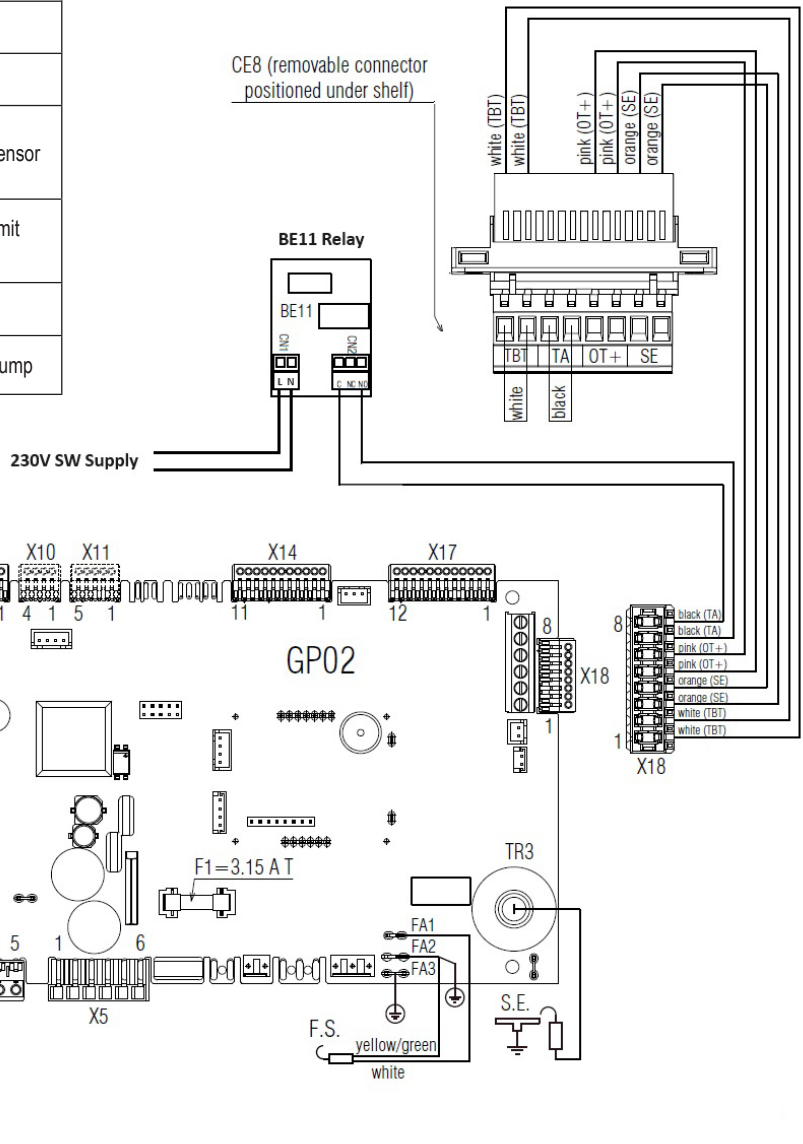

### ATTENTION

- Do not connect any high voltage (230V) power to the connections on CE4 or CE8.
- Any switched 'live' (230v L/N) supply must only be connected to the CN1 terminals on relay board BE11 (see below).
- Connect the Vokera external sensor to the SE connections on plug CE8 or terminals 3&4 (orange) on X18 of the PCB (see also 4.4).
- Connect the Opentherm control, e.g. Hi COMFORT to the OT+ connections on plug CE8 or terminals 5 & 6 (pink) on X18 of the PCB (see also 4.4).
- The TA connections on terminals 7 & 8 (black) of X18 are 'voltage-free' and MUST only be used to switch a 'voltage-free' external control, e.g. 2-wire room thermostat.
- Do not remove the white link-wire from plug CE8.

### NOTE

- Only connect the Vokera external sensor if there is no requirement for HW.
- See 4.6 if the supplied 'fly-lead' is unsuitable or of insufficient length.
- Please contact the Vokera technical helpline (0330 236 8630) if you require further information on any of the above.

## 5. COMMISSIONING & OPERATION

**NOTE:** please refer to 3/3A and use the appropriate PPE when carrying out any of the actions or procedures contained within this section.

### 5.1 GAS SUPPLY INSTALLATION

Inspect the entire installation including the gas meter, test for tightness and purge. Refer to BS 6891 (I.S. 813 in ROI) for specific instruction.

### 5.2 THE HEATING SYSTEM

The appliance contains components that may become damaged or rendered inoperable by oils and/or debris that are residual from the installation of the system, consequently it is essential that the system be flushed in accordance with the following instructions.

### 5.3 INITIAL FILLING OF THE SYSTEM

Ensure both flow and return service valves are open, remove appliance casing as described in 4.5, identify the automatic air release valves (AAV) and loosen the dust cap/s by turning the cap anti-clockwise one full turn. Ensure all manual air release valves located on the heating system are closed. Connect the filling loop (not supplied), slowly proceed to fill the system by firstly opening the inlet valve connected to the flow pipe, and then turning the lever on the fill valve, to the open position. As water enters the system the pressure gauge will begin to rise. Once the gauge has reached 1 BAR close both valves and begin venting all manual air release valves, starting at the lowest first. It may be necessary to go back and top-up the pressure until the entire system has been filled. Inspect the system for water tightness, rectifying any leaks.

### 5.4 INITIAL FLUSHING OF THE SYSTEM

The whole of the heating system must be flushed both cold and hot as detailed in 5.6. Open all radiator or heating valves and the appliance flow & return service valve. Drain the boiler and system from the lowest points. Open the drain valve full bore to remove any installation debris from the boiler prior to lighting. Refill the boiler and heating system as described in 5.3.

### 5.5 PRELIMINARY CHECKS

Before starting up the boiler, check:

- confirm via the appliance data badge, that the appliance is suitable/configured for the gas type and electrical supply that has been provided to the appliance
- inspect the entire flue system and ensure that it has been installed in accordance with these instructions and the relevant standards that apply locally and/or nationally
- that the required clearances have been met in respect of the requirements for maintenance
- inspect the entire installation including the gas meter, test for tightness and purge. Refer to BS 6891 (I.S. 813 in ROI) for specific instruction
- ensure that the rated delivery of the gas meter is adequate enough to serve this appliance and any other gas appliance connected to the same meter
- ensure that the gas supply pipework is of adequate size to provide the maximum gas rate required by this appliance
- check that the siphon is completely filled with water, otherwise fill it up (see chapter 5.7).

**⚠ Before connecting the “Hi, Comfort T300 or K100” devices, the Connectivity Menu must be set up correctly to avoid communication failure problems (see section 8.10).**

### 5.6 FINAL FLUSHING OF THE HEATING SYSTEM

The system shall be flushed in accordance with BS 7593 (I.S. 813 ROI). Should a cleanser be used, it must be suitable for stainless-steel heat exchangers. It shall be from a reputable manufacturer and shall be administered in strict accordance with the manufacturers' instructions and the DWTA code of practice.

**NOTE:** Chemicals used to cleanse the system and/or inhibit corrosion must be pH neutral, i.e. they should ensure that the level of the pH in the system water remains neutral. Premature failure of certain components can occur if the level of pH in the system water is out-with normal levels.

### 5.7 FIRST COMMISSIONING

On first ignition after prolonged inactivity and after maintenance, before putting the appliance into operation it is essential to proceed as described in the following paragraphs. At the first start-up, the calibration procedure (GAC) is also recommended to allow the boiler to reach its optimal performance. If the procedure is not performed, the display shows “CFG - GAC Not performed”. It is also essential to fill the condensate collection siphon by pouring about 1 litre of water into the boiler combustion analysis take-off and check:

- that the float within the trap is free and moving
  - the correct flow of water from the boiler outlet discharge pipe
  - there are no leaks of the condensate drain connection line.
- Correct operation of the condensate drain circuit (siphon and pipes) requires that the condensate level does not exceed the maximum level (max). Prior filling of the siphon and the presence of the safety float inside the siphon is designed to prevent the escape of combustion gases into the environment.

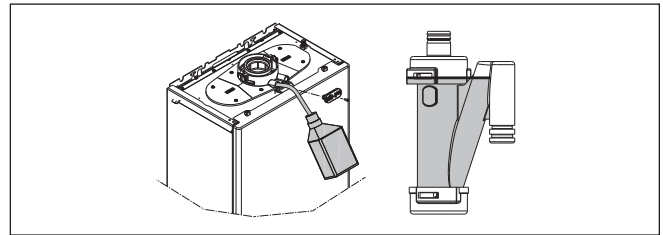

#### High efficiency mode (SERVICE)

In this mode, the boiler limits the power output in heating for 60 minutes to a minimum value. Activating the chimney sweep temporarily disables this function.

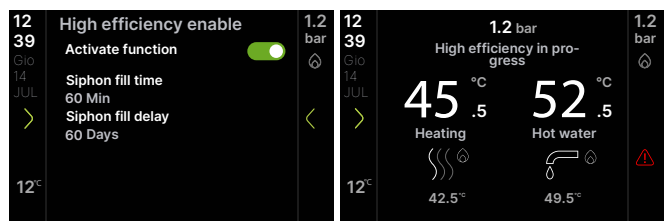
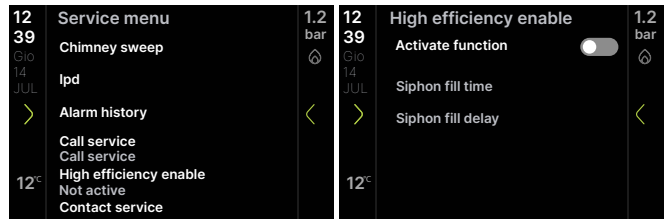

### 5.8 VENTING CYCLE

Turn the main system switch ON.

Every time the boiler is powered up, a vent cycle is run lasting 4 minutes.

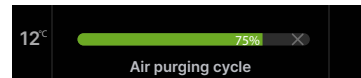

**⚠** When the vent cycle is running all heat requests are inhibited except for DHW requests when the boiler is not in OFF.

If the boiler is not in the OFF condition, the vent cycle can be interrupted by tapping the “x” on the progress bar.

### 5.9 MANUAL CALIBRATION PROCEDURE (GAC)

The GAC procedure, which is useful to calibrate the gas valve and combustion control system, is mandatory following: gas conversion - gas valve replacement - board replacement - fan replacement - cleaning of primary heat exchanger and/or burner - replacement of flame detection electrode (ionisation) - replacement of burner insulation panel - modification of suction/exhaust pipes.

The **GAC procedure must also be carried out on first start-up**. If this procedure is not carried out in the time required, the boiler will still be safe however it may be limited in performance and may also process combustion control signals.

**⚠ The procedure must be performed with the casing closed.**

The msg "CFG - call for GAC" is only displayed on the home page if the function has never been performed.

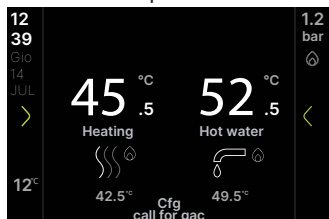

- Power up the boiler and wait for the vent cycle to run (see paragraph section 5.8).
- If in the OFF condition, set the boiler to WINTER.
- Generate a HEAT request. Although there are no limitations on the part of the system, except those foreseen by the ALARMS supervision, however, it is advisable to do the GAC scan with boiler return system water below 15°C or in any case with a temperature compatible with the flow rate of system water towards the boiler.
- Wait until the flame symbol appears on the display. No key must be pressed at this stage.

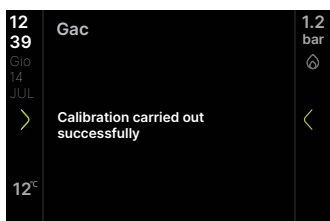
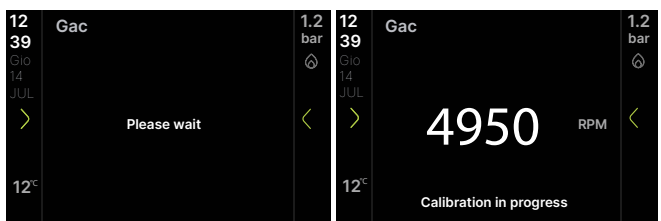
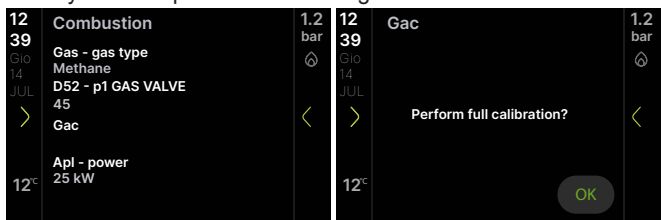

**NOTE:** If it is not possible to dissipate heat, it is still possible for high-temperature systems to carry out the GAC in a heating request by setting the heating water setpoint to 80.5°C, or even better, by activating the chimney sweep function and then, with the flame on, starting the GAC.

If the GAC is successfully completed, return to the main screen by pressing the HOME button; if the message "Calibration failed. Retry?" is displayed, you can repeat the procedure by pressing the OK button.

If the procedure is not carried out when it is mandatory to do so, this non-compliance may lead to a limited operation and the possibility of abnormal combustion control signals occurring.

If a fault occurs during the procedure or if the heat request is interrupted, the procedure would be terminated prematurely by displaying the fault status or automatically returning to the main screen. In this case, the procedure must be repeated.

## 5.10 SETTING THE THERMOREGULATION

**NOTE: Thermoregulation via an external sensor is unsuitable for systems that incorporate a domestic hot water cylinder.**

Thermoregulation is only available with an outdoor temperature sensor connected and is only active for the HEATING function.

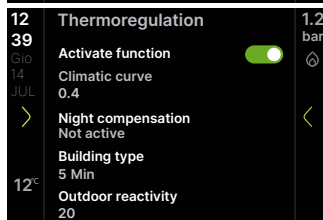
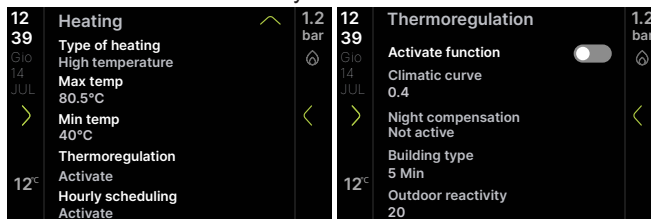

With the function not enabled or an outdoor temperature sensor, the boiler **works at a fixed-point**. The electronic thermostat algorithm will not use the measured outdoor temperature value directly, but rather an average outdoor temperature value, which takes account of the insulation of the building: in well-insulated buildings, outdoor temperature variations have less influence on the ambient temperature than in less insulated buildings.

This value together with the temperature detected by the outdoor temperature probe can be displayed in the following screen:

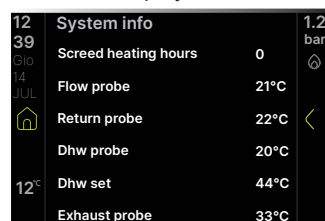

### REQUEST FROM OT CHRONOTHERMOSTAT

In this case, the delivery setpoint is calculated by the timed thermostat on the basis of the outdoor temperature value, and by the difference between the real ambient temperature and the required ambient temperature.

### REQUEST FROM ROOM THERMOSTAT

In this case, the delivery setpoint is calculated by the adjustment board on the basis of the outdoor temperature value, to obtain an estimated ambient temperature of 20° (reference ambient temperature). There are 2 parameters that are used to calculate the delivery setpoint:

- slope of the compensation curve (KT) - modifiable by technical personnel
- offset to reference ambient temperature - can be modified by the user.

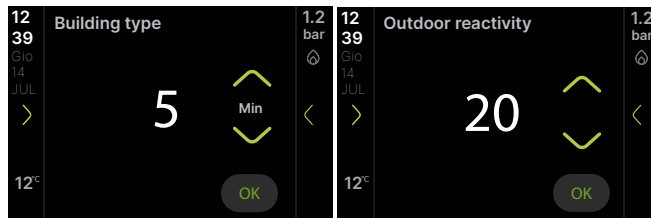

### TYPE OF BUILDING

It is indicative of the frequency with which the value of the calculated outdoor temperature for thermoregulation is updated, a low value for this value will be used for buildings that have little insulation.



**REACTIVITY SEXT**

It is an indication of the speed with which variations of the measured outdoor temperature affect the calculated outdoor temperature value for thermoregulation, low values indicate high speeds.

**CURVE SLOPE**

The heating thermoregulation curve maintains a theoretical temperature of 20°C in the room for outdoor temperatures between +20°C and -20°C. The choice of the curve depends on the minimum design outdoor temperature (and thus the geographical location) and the design flow temperature (and thereby the type of system) and should be carefully calculated by the installer, according to the following formula:

$$KT = \frac{\text{Project delivery T.} - \text{Tshift}}{20 - \text{min. outdoor project T.}}$$

Tshift = 30°C standard system  
25°C floor installations

If the calculation gives an intermediate value between two bends, you are advised to choose the thermoregulation bend closest to the value obtained.

**Example:** if the value obtained from the calculation is 1.3, it lies between curve 1 and curve 1.5. Choose the nearest curve, i.e. 1.5. The settable KT values are as follows:

- standard system: 1,0÷3,0
- free-standing system 0,2÷0,8.

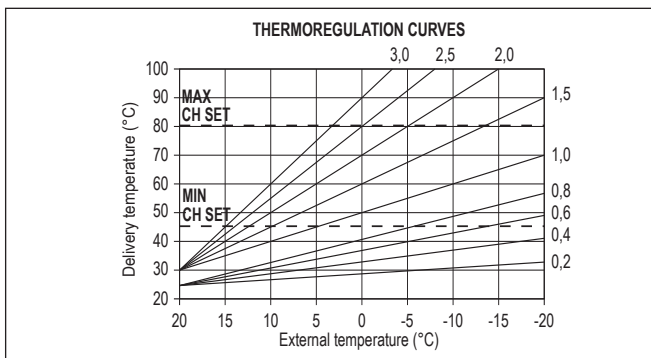

**Offset on the reference ambient temperature**

In any case, the user can indirectly modify the HEATING setpoint value by inserting an offset on the reference temperature (20°C). This offset may vary from -5 to +5 (offset 0 = 20°C). To correct the offset, refer to section section 8.4”.

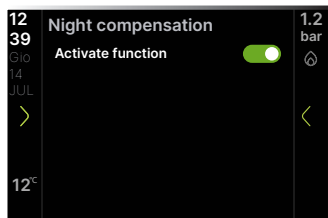
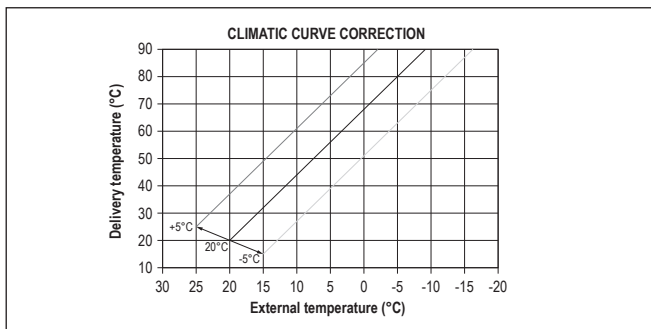

**NIGHT COMPENSATION**

If a time programmer is connected to the input ROOM THERMOSTAT the night compensation can be enabled. In this case, when the CONTACT is CLOSED, the heat request is made by the flow probe on the basis of the outdoor temperature, to obtain a nominal ambient DAY temperature (20°C). The OPENING OF THE CONTACT does not produce a switch-off, but rather a reduction (parallel shift) of the climatic NIGHT curve (16°C).

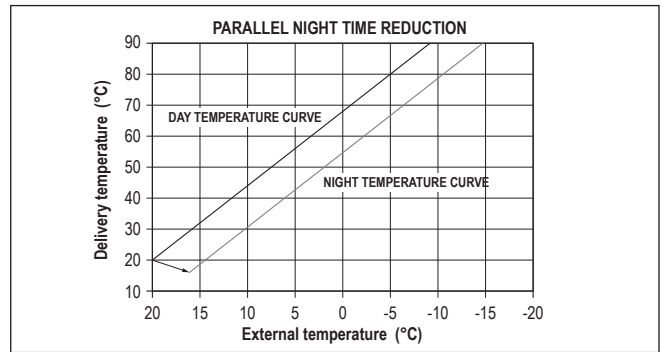

In this case too, the user can indirectly modify the HEATING setpoint value by inserting an offset on the reference DAY temperature (20°C) or NIGHT temperature (16°C). This offset may vary from [-5 to +5]. NIGHT COMPENSATION is not available if OT+ chrono is connected. To correct the offset, refer to section section 8.3.

**5.11 “COMFORT FUNCTIONS” & “SPECIAL DHW FUNCTIONS”**

These functions apply only to the combi version of this appliance; if they are displayed or activated, the appliance will require to be re-configured to the correct hydraulic configuration.

**5.12 SCREED HEATER FUNCTION**

If the system is at low temperature the boiler provides a ‘screed heater’ function (function only available in OFF-state) which can be activated as follows:

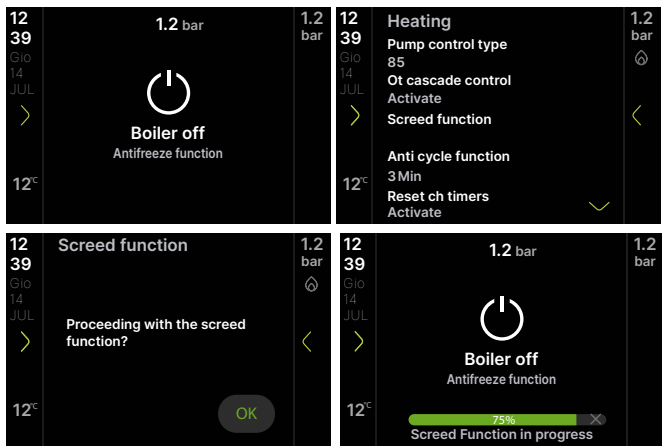

The screed heater function lasts 168 hours (7 days) during which, in the zones configured as low temperature, a heating request with initial zone delivery setpoint of 20°C is simulated, subsequently increased according to the table indicated below.

By accessing the ‘System Info’ menu, it is possible to display the value for the number of hours that have elapsed since the activation of the screed heater function. Once activated, the function takes priority, if the machine is shut down by disconnecting the power supply, when it is restarted the function picks up from where it was interrupted. The function can be interrupted before its end by switching the boiler to a state other than OFF or by disabling the parameter.

DAY	TIME	TEMPERATURE
1	0	20°C
	6	22°C
	12	24°C
2	18	26°C
	0	28°C
3	12	30°C
	0	32°C
4	0	35°C
	0	35°C
6	0	30°C
	0	25°C

Note: The temperature and increase values can be set to different values only by qualified personnel, only if strictly necessary. The manufacturer declines all responsibility if the parameters are incorrectly set.

## 5.13 COMBUSTION CHECK

 The checks of the settings of CO<sub>2</sub> in relation to the reference parameters, indicated in the tables below, must be carried out with the casing closed.

To carry out the combustion analysis, proceed as follows:

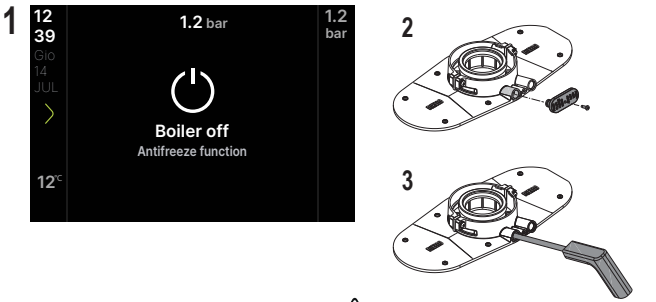

 The probe for the fumes analysis must be inserted until it reaches the stop.

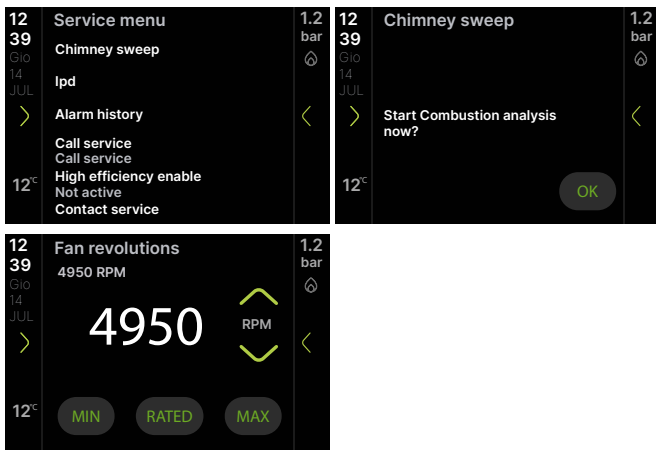

Holding down the heating and Wi-Fi keys will take you to the chimney sweep function page without going through the password-protected technical menu.



 With the chimney sweep function in progress, press the HOME button to activate the "GAC" procedure (follow the indications provided in section 5.9).

■ The display shows:

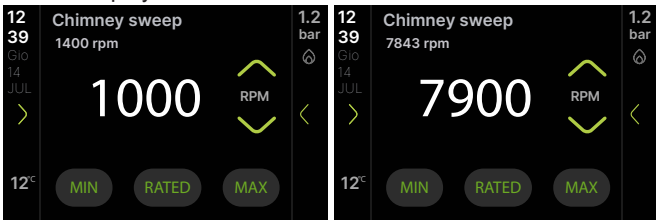

■ By setting the maximum value, the boiler will operate at maximum output; by setting the minimum value, the boiler will operate at minimum output.

Check on the analyser that CO<sub>2</sub> **max and minute values** comply with the following tables.

CO <sub>2</sub> * max		METHANE GAS (G20)	LIQUID GAS (G31)	
	20S	8,8	10,0	%
	25S	8,8	9,9	%
	32S	8,8	9,9	%
(*) CO <sub>2</sub> tolerance = ±1%				

CO <sub>2</sub> * min		METHANE GAS (G20)	LIQUID GAS (G31)	
	20S	8,8	10,0	%
	25S	8,8	10,0	%
	32S	8,8	10,0	%
(*) CO <sub>2</sub> tolerance = ±1%				

■ Check that the values of O<sub>2</sub> (max, nominal and min) related to 20% hydrogen mixture are in accordance with the following.

O <sub>2</sub> value relative to the 20% hydrogen mixture	Qmax		20S	25S	32S	
		max	%	2,4	2,4	2,4
		nominal	%	4,3	4,3	4,3
	min	%	6,2	6,2	6,2	
Qmin	max	%	2,4	2,4	2,4	
	nominal	%	4,3	4,3	4,3	
	min	%	6,2	6,2	6,2	

- The COMBUSTION ANALYSIS lasts a maximum of 15 minutes; the procedure can be terminated prematurely by pressing the (HOME) key.

- If the system is in low temperature, live, without mixing or thermostatic valves, the COMBUSTION ANALYSIS must be carried out in DHW request mode.

 COMBUSTION ANALYSIS is terminated prematurely if:

- the delivery temperature exceeds 95°C; it will ignite again when the temperature falls below 75°C
- a flame is not detected resulting in an alarm
- in the event of an alarm.

 With the "Config OT bus" function active, combustion control is not possible. To carry out the flue gases analysis, deactivate the function. Remember to reset the function once the combustion check has been completed.

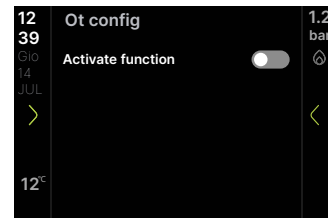

When the check has ended:

- exit the function by pressing "<"
- remove the analyser probe and close the combustion analysis outlet with the relative plugs and screw
- put the analysis probe adapter (supplied with the boiler) in the documentation envelope
- set the boiler to the required operating mode, depending on the season
- regulate the requested temperature values according to needs.

## 5.14 ADJUSTMENTS

The boiler has already been adjusted during manufacturing by the manufacturer. However, if it is necessary to carry out the adjustments again (for example after extraordinary maintenance, after replacing the gas valve, after a gas transformation or after replacing the board) follow the procedures described below.

Maximum and minimum power and maximum heating adjustments must be carried out only by qualified personnel:

- Power the boiler



- set the desired values by referring to tables 1 and 2
- check that the values on the two screens are the same.



The maximum heating fan speed used will be the one set in the RANGE RATED screen.

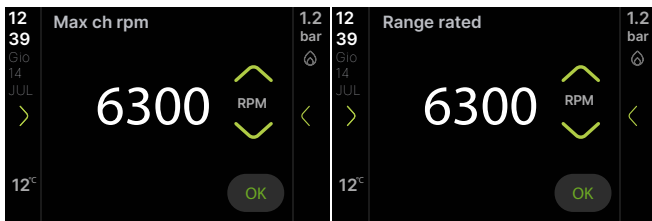

table 1

MAXIMUM NO. FAN ROTATIONS	METHANE GAS (G20)	LIQUID GAS (G31)	
20S	6,300	6,100	rpm
25S	6,200	5,800	rpm
35S	7,700	7,500	rpm

table 2

MINIMUM NO. FAN ROTATIONS	METHANE GAS (G20)	LIQUID GAS (G31)	
20S	1,000	1,250	rpm
25S	1,100	1,250	rpm
32S	1,100	1,250	rpm

## 5.15 GAS CONVERSION



Conversion from a family gas to other family gas can be performed easily also when the boiler is installed.



This operation must be carried out by professionally qualified personnel.

The boiler is designed to operate with methane gas (G20) according to the product label. It is possible to convert the boiler to LPG (G31) as follows:

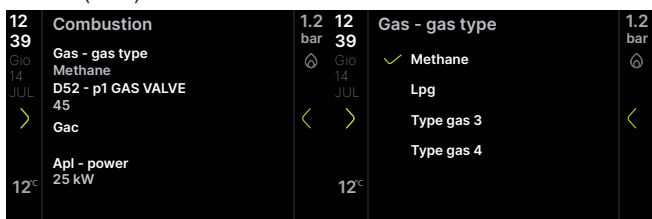

Switch the boiler off and on again after changing parameters.

Once the gas conversion has been carried out:

- check that the fan speed corresponds to the indications provided in tables 1 and 2, section section 5.15
- carry out a new "GAC" procedure (see section 5.9).

## 5.16 OUTPUT CHANGE

To change the boiler output type:

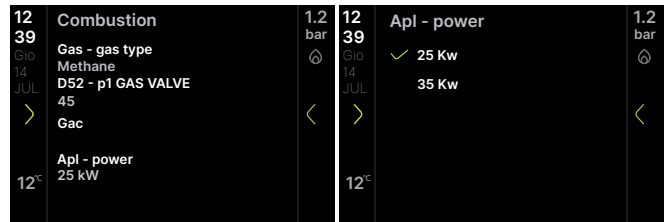

Configure the fan speeds of your boiler as indicated in tables 1 and 2, section section 5.15.

### MODEL 20kW

- select 25kW and modify the fan revolutions according to the indications provided in tables 1 and 2 of the relevant model.

### MODEL 30kW

- select 35kW and modify the fan revolutions according to the indications provided in tables 1 and 2 of the relevant model.



Disconnect and reconnect power to the boiler after changing the parameters.

## 5.17 SIGNALLING AND FAULTS

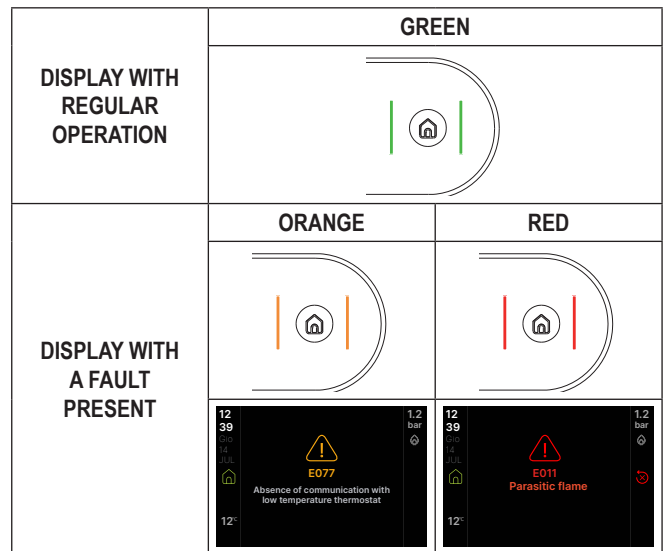

The presence of a fault is indicated with two different colours:

- orange: indicates that a self-resetting transient error is present which could limit the correct operation of the boiler
- red (together with the symbol ) indicates the presence of an error which will put the boiler into a lockout condition.

### Reset function

To restore operation of the boiler in the event of a fault, press . At this point, if the correct operating conditions have been restored, the boiler will restart automatically. A maximum of 5 consecutive unlocking attempts can be made from the interface, after which the interface displays

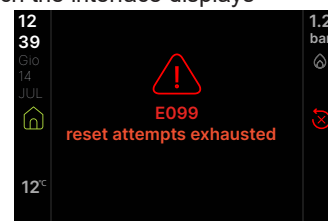

In this case, the boiler must be disconnected from the electricity supply and then reconnected again, to reactivate operation.



If the attempts to reset the boiler do not work, contact the Technical Assistance Centre.

## PRESSURE fault

When the pressure value falls below 0.5 bar, the following situations can occur:

### warning signal FIL



The boiler is operating normally, but it is still recommended to fill the system in the way described in section “4.1 HOW TO TOP-UP THE SYSTEM PRESSURE” page 8.

### temporary fault - E041

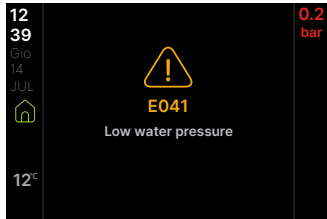

The boiler is not working properly. Fill the system as described in the previous point; operation required within 10 minutes of the message appearing otherwise the anomaly becomes definitive (E040).

### definitive fault - E040

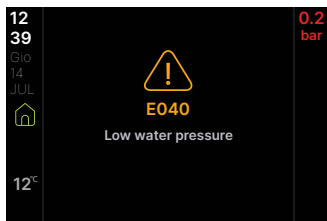

In the event of a permanent lockout, fill the system and then release the alarm.

Press  to restore operation.

Once operation is restored, the boiler performs an automatic vent cycle.

 If the drop in pressure is very frequent, request the intervention of the Technical Assistance Centre.

## DHW PROBE fault (E060)

Indicates a possible configuration error; please contact Vokera Technical or the Service Centre for assistance.

## PRIMARY HEAT-EXCHANGER CLEANING fault (E091)

The boiler has an auto-diagnostic system which, based on the total number of hours in certain operating conditions, can signal the need to clean the primary heat exchanger. Once the cleaning operation has been completed with the cleaning kit supplied as an accessory, it is necessary to reset the total hours meter as follows:

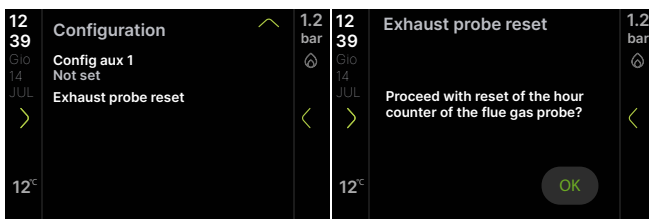

NOTE: The meter resetting procedure should be carried out after each in-depth cleaning of the primary exchanger or if this latter is replaced.

The fault occurs when the hour meter exceeds 2500 hours; this value can be verified as follows:

- access the “System Info” menu to display the value of the flue gas probe meter (display/100, example 2500h = 25).

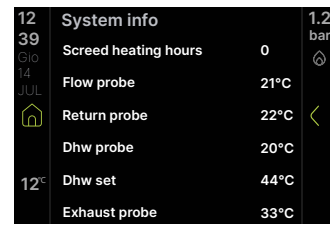

## 5.18 REPLACING THE GAS VALVE

After replacing the gas valve it is necessary to reset the value P1 (see photo) as follows:

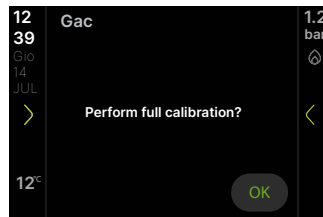
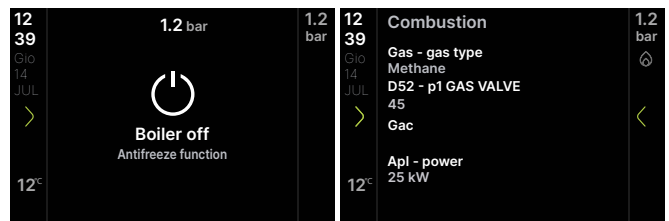

- using the arrows, enter the second and third digits of the value P1 (e.g. 034 becomes 34) shown on the gas valve present in the boiler (each gas valve has its own offset P1 value), confirm.

 **Disconnect the boiler from the power supply for at least 10 seconds; then reconnect to the mains power supply.**

Once the replacement is complete, a new “GAC” procedure must be carried out (see section 5.9).

 If the gas valve is replaced, also replace the relative sealing gaskets.

To tighten the gas valve ramp nut, apply a torque equal to 25 Nm, limiting the rotation of the valve.

## 5.19 REPLACING THE INTERFACE

System configuration operations must be carried out by professionally qualified personnel of the Technical Assistance Centre.

If the interface card is replaced, the user may be asked to reset the time and day of the week values at power on (see section 5.7); also check and reset, if necessary, information on hourly heating and DHW programming (see section 8.1) and the Feeder Bottle function (see section 8.11); note that no reprogramming of the configuration parameters is necessary, the value of which is retrieved from the regulation and control board in the boiler. Instead, it may be necessary to reset the DHW and/or heating setpoint values.

## 5.20 BOARD REPLACEMENT

If case of the control board is replacement and adjustment procedure, it may be necessary to check the configuration parameters and possibly reconfigure them. Consult the parameter table to identify the board default values, the factory set values and the customized ones.

The parameters to necessarily be checked and possibly reset are: GAS - GAS TYPE • d52 - P1 GAS VALVE (with boiler

in OFF) • APL - POWER • HYDRAULIC CONFIGURATION • WATER PRESSURE TRANSDUCER (SERVICE) • MIN FAN SPEED • MAX FAN SPEED • MAX FAN SPEED HTG • RANGE RATED.

Disconnect the boiler from the power supply for at least 10 seconds; then reconnect to the mains power supply. Once the replacement is complete, perform a new "GAC" procedure must be carried out (see section 5.9).

ERROR CODE	ERROR MESSAGE	ERROR TYPE DESCRIPTION	
E010	MAXIMUM NUMBER OF IGNITION ATTEMPTS	DEFINITIVE	
E011	PARASITIC FLAME		
E012	MAXIMUM NUMBER OF FLAME LOSSES		
E013	SERIAL PROTOCOL		
E014	FLAME DETECT TEST FAILED		
E015	VOLTAGE DETECT FLAME TEST FAILED		
E020	LIMIT THERMOSTAT		
E021	GAS VALVE CONTROL MALFUNCTION		
E030	FAN ERROR		
E031	FAN FAILURE MECHANICAL BLOCKAGE		
E032	ROTOR FAN FAILURE BLOCKED		
E033	ROTOR FAN FAILURE DAMAGED		
E034	CHIMNEY OBSTRUCTION IN PREVENTILATION		
E035	BLOCKAGE OBSTRUCTION FLUE GAS LOW POWER		
E036	BLOCKAGE OBSTRUCTION FLUE GAS HIGH POWER		
E037	FAILED COMBUSTION CHECK LOW POWER		
E038	COMBUSTION CHECK FAILED HIGH POWER		
E039	ABNORMAL FLAME VALUE		
E040	LOW WATER PRESSURE		
E042	WATER TRANSDUCER - LWCO ERROR		
E071	HEATING TEMPERATURE OVER LIMIT		
E075	VALVE OPENING LIMIT REACHED		
E081	RETURN TEMPERATURE OVER LIMIT		
E088	CAC FAILED		
E090	EXHAUST PROBE ERROR		
E092	CALIBRATION FAILED		
E093	TOO MANY CALIBRATION ATTEMPTS		
E094	LAMBDA OVER LIMIT		
E097	Check FAILED		
E098	GAC FAILED		
E099	RESET ATTEMPTS EXHAUSTED		
E041	LOW WATER PRESSURE		TRANSITORY
E050	SMOKE OBSTRUCTION ERROR LOW POWER		
E051	SMOKE OBSTRUCTION ERROR HIGH POWER		
E052	HARDWARE ERROR OUT OF THRESHOLD		
E055	NO CARD FAN COMMUNICATION		
E056	NO COMMUNICATION MICROPROCESSOR CARD		
E060	CONFIGURATION ERROR		
E070	CH PROBE ERROR		
E071	HEATING TEMPERATURE OVER LIMIT		
E072	DELTA T RETURN OUT OF LIMIT		
E077	ABSENCE OF COMMUNICATION WITH LOW TEMPERATURE THERMOSTAT		
E080	RETURN PROBE ERROR		
E081	RETURN TEMPERATURE OVER LIMIT		
E082	WARNING DELTA TEMPERATURE		
E090	EXHAUST PROBE ERROR		
E091	CLEAN PRIMARY HT EXCHANGER		
E095	CALIBRATION FAILED		
E096	LAMBDA OVER LIMIT		
FIL	LOW WATER PRESSURE CHECK THE HTG SYSTEM		
pressure value	HIGH WATER PRESSURE CHECK THE HTG SYSTEM	SIGNAL	
COM	APPLIANCE PCB COMMUNICATION LOST (more than 30 seconds)	SIGNAL: (the boiler continues to operate but with no display or keys)	
E065	IMOD ERROR	SIGNAL	
FWER	WARNING FIRMWARE VERSIONS NOT COMPATIBLE	SIGNAL: (the boiler continues to operate but with no display or keys)	
CFS	CALL FOR SERVICE	SIGNAL	
SFS	STOP FOR SERVICE	DEFINITIVE	
OBCD	ON BOARD CLOCK DAMAGED	SIGNAL: (the boiler continues to operate but with no display or keys)	
LLL	GENERIC FIRMWARE BLOCK	SIGNAL	
CFG	GAC NOT EXECUTED	SIGNAL	

## 6. MAINTENANCE AND CLEANING

Periodic maintenance is essential to the safety, efficiency and duration of the boiler. It allows for the reduction of consumption, polluting emissions and keeping the product safe and reliable over time. Before starting maintenance operations:

- turn off the fuel and water taps of the heating and domestic hot water system.

To ensure product characteristics and efficiency remain intact and to comply with current regulations, it is necessary to render the appliance to systematic checks at regular intervals.

This normally means the following tasks: 

- removing any oxidation from the burner
- removing any scale from the heat exchangers
- check the state of deterioration of the electrodes and, if they have deteriorated, replace them together with their seals
- check and general cleaning of exhaust and intake pipes
- checking the external appearance of the boiler
- checking the ignition, switch-off and operation of the appliance, in heating mode
- checking the seal on the couplings and the gas/water/condensate connection pipes
- checking gas consumption at maximum and minimum output
- checking the integrity of the insulation of electrical cables, particularly in the vicinity of the primary heat exchanger
- checking the gas failure safety device
- checking and cleaning the siphon
- checking the cleanliness of the fan, internal extraction (including the air filter when provided)
- **checking there is water in the drain-trap; if not, fill it.**

 The electronic board and the gas valve do not require a specific check aimed at evaluating aging and deterioration.

 When servicing the boiler, the use of protective clothing is recommended in order to avoid personal injury.

 After maintenance work has been carried out, an analysis of the combustion products must be carried out to check that they are functioning properly.

 Do not clean the appliance or its parts with inflammable substances (e.g. petrol, alcohol, etc.).

 Do not clean panels, painted parts and plastic parts with paint thinner.

 Panel cleaning must be carried out only with soapy water.

### Cleaning the primary heat exchanger

- Switch off the electrical supply by turning the main system switch OFF.
- Close the gas shut-off valve.
- Remove the casing as explained in section 4.5.
- Disconnect the connection cable of the ignition and detection electrodes.
- Disconnect the power cables of the fan.
- Remove the clip securing the gas train from the mixer.
- Loosen the gas train nut.
- Extract the gas train from the mixer and rotate it.
- Remove the 4 nuts that secure the combustion unit.
- Remove the air/gas conveyor assembly including fan and mixer, taking care not to damage the insulation panel and electrode.
- Remove the siphon connecting pipe from the condensate drain fitting of the heat exchanger and connect a temporary collecting pipe. At this point proceed with the heat exchanger cleaning operations.
- Vacuum out any dirt residue inside the heat exchanger, taking care NOT to damage the retarder insulating panel.
- Clean the coils of the heat exchanger with a soft bristled brush.

 DO NOT USE METAL BRUSHES THAT COULD DAMAGE THE COMPONENTS.

- Clean the spaces between the coils using a 0.4 mm thick blade or similar.
- Vacuum away any residue produced by the cleaning intervention.
- Rinse with water, taking care NOT to damage the retarder insulating panel.

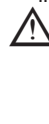
 If there are stubborn fuel gas deposits on the heat exchanger surface, remove them by spraying with natural white vinegar, taking care NOT to damage the retarder insulating panel.

- Leave it to work for a few minutes.
- Clean the coils of the heat exchanger with a soft bristled brush.

 DO NOT USE METAL BRUSHES THAT COULD DAMAGE THE COMPONENTS.

- Rinse with water, taking care NOT to damage the retarder insulating panel.
- Make sure the retarder insulation panel is undamaged and replace it if necessary following the relative procedure.
- After cleaning, carefully assemble the components again repeating the indications provided above but in the reverse order.
- To tighten the fastening nuts of the air/gas conveyor assembly, use a tightening torque of 6 Nm, following the sequence indicated on the die-cast (1,2,3,4).
- Turn the power and gas feeding to the boiler back on.

 It is necessary to carry out a new "GAR" procedure followed by the "GAC" procedure (see section 5.9).

 What is indicated is also valid in the case of replacement of the conveyor alone, the exchanger or the conveyor and exchanger assembly.

### Cleaning the burner

- Switch off the electrical supply by turning the main system switch OFF.
- Close the gas shut-off valve.
- Remove the casing as explained in section 4.5.
- Disconnect the connection cable of the ignition and detection electrodes.
- Disconnect the power cables of the fan.
- Remove the clip securing the gas train from the mixer.
- Loosen the gas train nut.
- Extract the gas train from the mixer and rotate it.
- Remove the 4 nuts that secure the combustion unit.
- Remove the air/gas conveyor assembly including the fan and mixer, taking care not to damage the insulating ceramic panel and the electrodes. At this point proceed with the burner cleaning operations.
- Clean the burner with a soft bristle brush, taking care not to damage the insulation panel and electrodes.

 DO NOT USE METAL BRUSHES THAT COULD DAMAGE THE COMPONENTS.

- Check that the burner insulating panel and the sealing gasket are undamaged and replace them if necessary, following the relative procedure.
- After cleaning, carefully assemble the components again repeating the indications provided above but in the reverse order.
- To close the fixing nuts of the air/gas conveyor assembly, use a tightening torque of 6 Nm.
- Turn the power and gas feeding to the boiler back on.

 Carry out an analysis of the combustion products. Only if it returns values outside of tolerance, it is necessary to repeat a new "GAR" procedure followed by the "GAC" procedure (see section 5.9).

 What is indicated is also valid in the case of replacement of the conveyor alone, the exchanger or the conveyor and exchanger assembly.

### Replacing the burner insulating panel

- Loosen the screws holding the ignition/detection electrode, and remove it.
- Remove the burner insulating panel by inserting a blade just under the surface.
- Remove any residual fixing adhesive.
- Fit the new burner insulating panel.
- The new insulating panel does not need to be fixed with an adhesive as its geometric form ensures perfect coupling with the heat exchanger flange.
- Refit the ignition and detection electrodes using the screws previously removed and replacing the relevant seal. To tighten the screws, apply a torque of 2.3 Nm.

 Do not perform GAR and/or GAC.

### Siphon check and cleaning

- Disconnect the pipes (A - B), remove the clip (C) and remove the drain-trap.
- Clean the parts of the drain-trap to remove any solid residue.

- ⚠ Carefully reposition the previously removed components.
- ⚠ At the end of the cleaning sequence, fill the drain-trap with water (see section 5.7) before re-starting the boiler.
- ⚠ Do not perform GAR and/or GAC.
- ⚠ What is indicated also applies in the case of replacing the siphon.

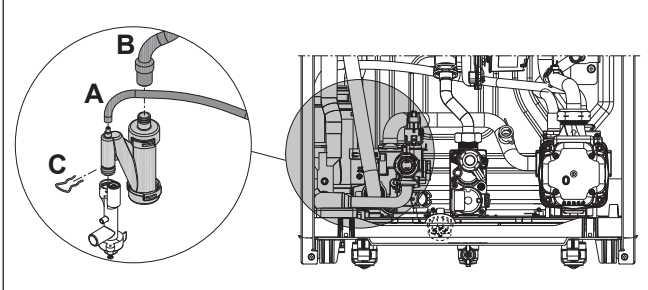

### Ignition and detection electrodes

The ignition and detection/ionization sensor electrodes perform an important function in the boiler ignition phase and in maintaining correct combustion; in this regard, during annual maintenance, it is necessary to always check that they are correctly positioned and that the reference dimensions indicated in the figure are strictly respected.

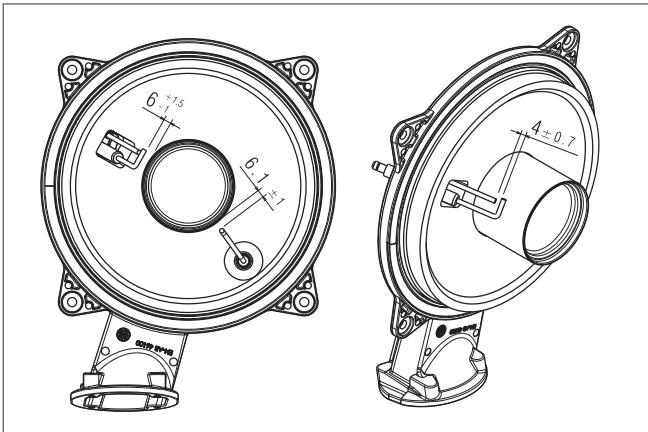

- ⊘ Do not sand the electrodes. If the electrodes need to be cleaned, dust them using a soft bristle brush.

- ⚠ In the event of deformation and deterioration of the electrodes outside the tolerances, replace them.

To tighten the screws, apply a torque of 2.3 Nm.

- ⚠ In order to prevent potential operating anomalies, the ignition and detection/ionisation sensor electrodes must be replaced every 5 years.

- ⚠ It is necessary to carry out a new "GAR" procedure followed by the "GAC" procedure (see section 5.9).

### Cleaning the air filter

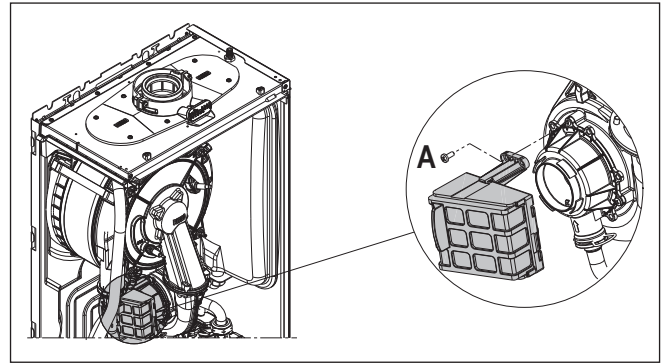

- Unscrew the fixing screw A and extract the air filter.
- Blow compressed air over the filter to remove any impurities.
- In the event of persistent dirt, wash with water.

- ⚠ It is necessary to carry out a new "GAR" procedure followed by the "GAC" procedure (see section 5.9).

### Board replacement

- The control and regulation board does not provide a specific procedure for verifying its deterioration. In case of replacement, refer to section 5.21.

### Interface board replacement

- The interface board does not provide a specific procedure for verifying its deterioration. In case of replacement, refer to section 5.20.

### Gas valve replacement

- The gas valve does not provide a specific procedure for checking its deterioration. In case of replacement, refer to section 5.19.
- The gas valve does not provide a specific cleaning procedure.

## 7. PASSWORD SETTING FOR ACCESSING AND CHANGING PARAMETERS IN THE TECHNICAL MENU

In the manual, follow the procedure described whenever a password needs to be entered in order to access parameters:



### 7.1 PROGRAMMABLE PARAMETERS

Below is a list and description of the programmable parameters: USER (always available) and INSTALLER (access with psw 18): set the password as indicated in the previous chapter.

 **Some of the information and functions indicated below may not be available depending on the access level, status and type of machine or system configuration.**

		WHICH PARAMETERS ARE VISIBLE/ACCESSIBLE		
		USER	INSTALLER	SERVICE
LEVEL PASSWORD	USER (always available)	X		
	INSTALLER (psw 18)	X	X	
	SERVICE	X	X	X

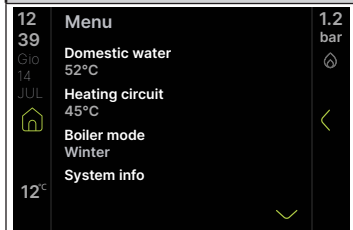
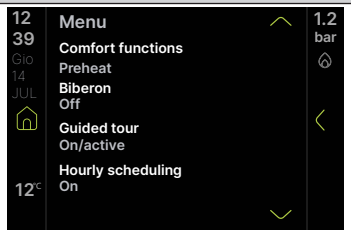
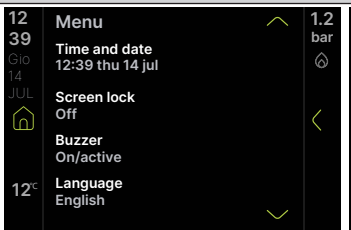
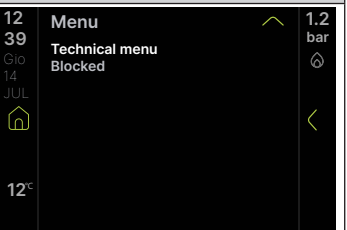
USER MENU (access level USER)			
			
<b>Domestic Hot Water</b> → <b>DHW Temperature:</b> to set the DHW temperature (for more details please refer to "Heating and DHW setpoint setting"). NOT AVAILABLE ON THIS MODEL.	<b>Heating Circuit</b> → <b>Heating Circuit Temperature:</b> to set the temperature of the heating circuit (for more details please refer to "Heating and DHW setpoint setting").	<b>Boiler Mode</b> → <b>Boiler Mode:</b> to set the boiler operating mode (for more details please refer to "Operating mode").	<b>System Info</b> → <b>Menu Info:</b> to consult the system info (for more details please refer to "INFO Menu").
<b>Comfort Functions</b> → <b>Comfort Functions:</b> to enable/disable comfort functions (for more details please refer to "Comfort Functions"). NOT AVAILABLE ON THIS MODEL.	<b>Biberon Function</b> → <b>Biberon function:</b> to enable/disable the bottle function (for more details please refer to "Feeder Bottle Function"). NOT AVAILABLE ON THIS MODEL.	<b>Guided tour</b> → <b>Guided tour:</b> to access the guided tour (for more details please refer to "GUIDED TOUR").	<b>Timer Programming</b> → <b>Timer Programming:</b> to set the TIMER PROGRAMMING, when enabled.
<b>Time and Date</b> → <b>Time and Date:</b> to set TIME AND DAY (for more details please refer to "INSTRUCTIONS FOR USE").	<b>Key Lock</b> → <b>Key and Screen Lock:</b> to lock/unlock keys and touch screen (for more details please refer to section "Keypad lock function").	<b>Buzzer</b> → <b>Buzzer:</b> to enable/disable the buzzer (for more details please refer to "INSTRUCTIONS FOR USE"). Factory setting = active	<b>Language</b> → <b>Language:</b> to set the desired language (for more details please refer to "INSTRUCTIONS FOR USE").
<b>Units of Measurement</b> → <b>Units of Measurement:</b> to change the unit of measurement. NOT CURRENTLY AVAILABLE.			



## TECHNICAL MENU (access level INSTALLER)

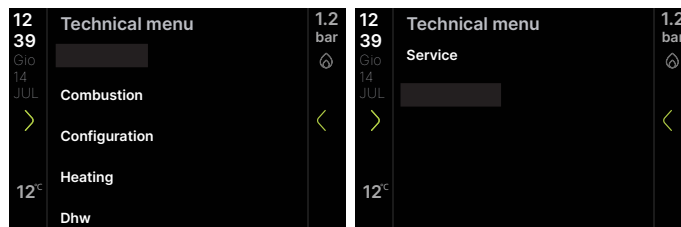

### Combustion →:

- **GAS - GAS TYPE:** parameter identifying the type of gas: Methane ● LPG ● Gas 3 ● Gas 4.  
Factory setting = Methane
- **d52 - P1 GAS VALVE:** parameter for resetting the P1 value of the gas valve.  
Factory setting = 45
- **GAC - VALVE CALIBRATION:** parameter used to calibrate the gas valve and combustion control system.
- **APL - POWER:** parameter used to set the boiler output: 25kW - 35kW.  
Factory setting = 25kW

### Configuration →:

- **HYDRAULIC CONFIGURATION:** to set the hydraulic configuration of the boiler: Heating only - Instantaneous with Flow switch - Instantaneous with Flow meter - Storage Cylinder with probe - Storage Cylinder with Thermostat.  
Factory setting = Heating only, do not modify. When replacing the circuit board, make sure that this parameter is set to Heating only.
- **MIN FAN SPEED:** to change the minimum fan speed.  
Factory setting = see technical data table.
- **MAX FAN SPEED:** to change the maximum rpm of the fan.  
Factory setting = see technical data table.
- **MAX FAN SPEED HTG:** to vary the maximum heating fan speed (this can be programmed within the minimum fan speed range - maximum fan speed).  
Factory setting = see technical data table.
- **Range Rated:** RANGE RATED adjustment. DO NOT CHANGE.
- **CONFIG AUX 1:** to configure the operation of an additional relay (only if BE09 board is installed (accessory kit)) to feed a phase (230Vac) to a second heating pump (additional pump) or a zone valve. It is to choose how to programme operation by choosing between: This depends on the wiring configuration of the BE09 board: cut jumper: additional pump - jumper present: zone valve (factory setting) ● zone valve management ● additional pump management.  
Factory setting = function not enabled.
- **EXHAUST PROBE RESET:** allows the operating hours counter to be reset under certain conditions (for more details please refer to "Warning signals and faults", fault E091).  
Factory setting = function not enabled.

### Heating →:

- **PUMP CONTROL TYPE:** proportional variable speed pump.  
Factory setting = 85.
- **OT CASCADE CONTROL:** allows the boiler to be set up for cascade applications via OT+ signal. NOT APPLICABLE TO THIS BOILER MODEL.
- **SCREED FUNCTION:** enables/disables the screed heater function (for more details please refer to "Screed heater function").  
Factory setting = function not enabled.
- **ANTI CYCLE FUNCTION:** allows the forced heating off time to be modified. This relates to the delay time introduced for re-ignition of the burner when the burner is switched off due to having reached the heating temperature.  
Factory setting = 3 minutes and can be set to a value between 0 min and 30 min.
- **RESET CH TIMERS:** Allows you to cancel the function HEATING RESET TIMING and REDUCED HEATING MAXIMUM OUTPUT, during which the fan speed is limited between the minimum value and 60% of the set maximum heating power, with an increase of 10% every 15 minutes.  
Factory setting = function not enabled.
- **TYPE OF HEATING:** allows you to specify the type of zone to be heated, choosing from the following options: HIGH TEMPERATURE ● LOW TEMPERATURE.  
Factory setting = HIGH TEMPERATURE
- **MAX TEMP:** allows the maximum heating setpoint value to be specified: range 20°C - 80°C, default 80°C for high temperature systems ● range 20°C - 45°C, default 45°C for low temperature systems. Note: The maximum heating setpoint value cannot be smaller than the minimum heating setpoint value.
- **MIN TEMP:** with this parameter you can specify the minimum settable heating setpoint: range 20°C - 80°C, default 40°C for high temperature systems ● range 20°C - 45°C, default 20°C for low temperature systems. Note: The minimum heating setpoint value cannot be greater than the maximum heating setpoint value.
- **THERMOREGULATION:** enables thermoregulation when an outdoor temperature sensor is connected to the system.  
Factory setting = function not active, the boiler always operates at fixed point. With the outdoor temperature sensor disconnected, the boiler works at a fixed setpoint. For more details, please refer to the section 'Setting the thermoregulation'.
- **HOURLY SCHEDULING:** enables hourly heating programming.  
Factory setting = DISABLE.
- **MANUAL FORCING DURATION:** with time programming enabled, this parameter allows you to set the switching mode from manual to automatic heating operating mode. The transition from manual to automatic time programming occurs automatically at the first time slot change.

### DHW →:

- **ANTI LEGIONELLA FUNCTION:** function linked to the availability of a storage cylinder. NOT AVAILABLE ON THIS MODEL.
- **ANTI LEG. DELAY:** function related to the availability of a storage cylinder. NOT AVAILABLE ON THIS MODEL.
- **SUPPLY TEMPERATURE:** function linked to the availability of a storage cylinder. NOT AVAILABLE ON THIS MODEL.
- **TANK HYSTERESIS ON:** function related to the availability of a storage cylinder. NOT AVAILABLE ON THIS MODEL.
- **TANK HYSTERESIS OFF:** function related to the availability of a storage cylinder. NOT AVAILABLE ON THIS MODEL.
- **TANK FLOW TEMP :** function related to the availability of a storage cylinder. NOT AVAILABLE ON THIS MODEL.
- **MODULATING TANK SUPPLY TEMP:** function related to the availability of a storage cylinder. NOT AVAILABLE ON THIS MODEL.
- **MIN TEMP:** to set the minimum DHW setpoint.  
Factory setting = 37°C
- **MAX TEMP:** to set the maximum DHW setpoint.  
Factory setting = 60°C.
- **SPECIAL FUNCTIONS:** to enable the special DHW functions. NOT AVAILABLE ON THIS MODEL.

### Service →:

- **CHIMNEY SWEEP:** to carry out combustion analysis, only with the boiler in the OFF position. For more details, please refer to the section 'Combustion control'.

## TECHNICAL MENU (access level SERVICE)

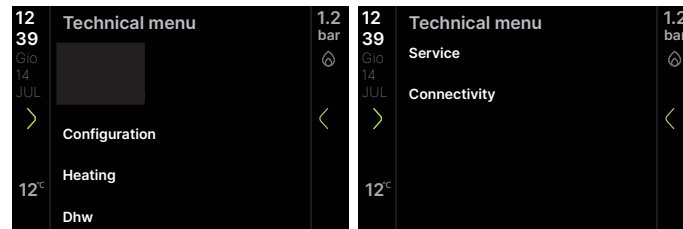

### Configuration →:

- **WATER PRESSURE TRANSDUCER:** to set the water pressure transducer type: water pressure switch - pressure transducer.  
Factory setting = pressure transducer, do not modify. When replacing the circuit board, make sure that this parameter is set to 'pressure transducer'.
- **AUTO-FILL ENABLE:** to enable the 'semi-automatic filling' function when a pressure transducer and a solenoid valve are installed in the boiler. NOT AVAILABLE ON THIS MODEL.
- **BEGIN SYSTEM FILLING:** only appears if 'Semi-automatic filling' is enabled. NOT AVAILABLE ON THIS MODEL.
- **AIR PURGING CYCLE:** to disable the vent cycle function.  
Factory setting = "function enabled". For more details, please refer to the section 'Vent Cycle'.

### Heating →:

- **HYST ON HIGH TEMP:** for high temperature systems, this parameter allows you to set the hysteresis value used by the control board to calculate the burner ignition delivery temperature: IGNITION TEMPERATURE = HEATING SETPOINT - Hysteresis ON High temp.  
Factory setting = 5°C, can be changed in the range 2°C- 10°C.
- **HYST OFF HIGH TEMP :** for high temperature systems, this parameter allows you to set the hysteresis value used by the control board to calculate the burner shutdown delivery temperature: SWITCH-OFF TEMPERATURE = HEATING SETPOINT + Hysteresis OFF High temp.  
Factory setting = 5°C, can be changed in the range 2°C- 10°C.
- **HYST ON LOW TEMP:** for low temperature systems, this parameter allows you to set the hysteresis value used by the control board to calculate the burner ignition delivery temperature: IGNITION TEMPERATURE = HEATING SETPOINT - Hysteresis ON Low temp.  
Factory setting = 3°C, can be changed in the range 2°C- 10°C.
- **HYST OFF LOW TEMP:** for low-temperature systems, this parameter allows you to set the hysteresis value used by the control board to calculate the burner shutdown delivery temperature: SWITCH-OFF TEMPERATURE = HEATING SETPOINT + Hysteresis OFF Low temp.  
Factory setting = 3°C, can be changed in the range 2°C- 10°C.

### DHW →:

- **DHW DELAY:** through this parameter a delay in seconds is introduced on the activation of the pump and fan when there is a DHW request. NOT AVAILABLE ON THIS MODEL.  
Factory setting = function not enabled.
- **POST-CIRCULATION:** through this parameter it is possible to enable/disable the DHW post-circulation function with heating start inhibition. When this function is active, it is possible to set the duration of DHW post-circulation. NOT AVAILABLE ON THIS MODEL.  
Factory setting = function not enabled.

### Service →:

- **ALARM HISTORY:** to activate the storage of an alarm history.  
Factory setting = function not enabled; the parameter is automatically enabled after 2 hours of operation. Disabling the parameter resets the alarm history. Please refer to the section 'Alarm History' for more details.
- **CALL SERVICE:** this parameter allows periodic control of the boiler according to a pre-set operating period. With function enabled (factory setting) it is possible to set:
  - "Call for service" (factory setting): the display shows CFS signalling without any operating stops. In this condition, the INFO menu displays the number of days that have elapsed since the CFS alert appeared. The CFS signal occurs at 10 minute intervals for a duration of 1 minute, 1 month before the end of the period set in the parameter "Service expiry"
  - "Stop for service": the display shows the SFS signal indicating the permanent inhibition of all heating and DHW heat requests. Cannot be reset.
  - "Service expiry": pre-set period of operation for the service call. Factory setting: 52 weeks
- **HIGH EFFICIENCY ENABLE:** automatic function which activates when first powered on or after 60 days of non-use (boiler electrically powered). In this mode the boiler, for 60 minutes, limits the power in heating to a minimum and the maximum temperature in DHW to 55°C. Activating the chimney sweep temporarily disables this function.  
Factory setting = function not enabled. For more details, please refer to the section 'Condensate trap filling - High efficiency mode'.
- **CONTACT SERVICE:** through this parameter you can enter the data of the Technical Assistance Centre.

### Connectivity →:

- **BUS 485 CONFIG:** this parameter is used to enable remote boiler management. Three values are available:
  - Wi-Fi key: management from boiler interface and APP if Wi-Fi key present (FACTORY SETTING)
  - Ignore Wi-Fi key: management from boiler interface ONLY
  - Modbus remote control: management from boiler interface and system manager (T300)
- **OT CONFIG:** this parameter is used to enable/disable the possibility of remote control of the boiler via an OpenTherm device.  
Factory setting = function enabled.

## 7.2 INFO MENU



If no buttons are pressed, after 120 sec, the interface automatically exits the 'System Info' menu.

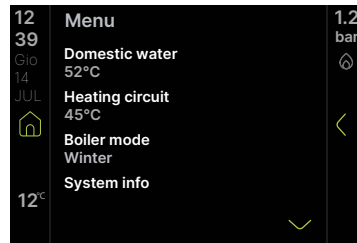

12 39 Gio 14 JUL 12°C	<b>System info</b>	1.2 bar	12 39 Gio 14 JUL 12°C	<b>System info</b>	1.2 bar	12 39 Gio 14 JUL 12°C	<b>System info</b>	1.2 bar	12 39 Gio 14 JUL 12°C	<b>System info</b>	1.2 bar
	Screed heating hours	0		Oat	3°C		Ot main zone set	---		Ch supply avg	28°C
	Flow probe	21°C		Filtered oat	1°C		Water pressure	1.0bar		Dhw supply avg	45°C
	Return probe	22°C		Dhw flow rate	0.0		Dhw hour	1		Ch return avg	21°C
	Dhw probe	20°C		Fan revolutions	0		Ch hour	2		Dhw return avg	34°C
	Dhw set	44°C		Exhaust hours	0		Dhw modulation	98%		Evg on cycles	21
	Exhaust probe	33°C		Main zone set	72		Ch modulation	40%		High efficiency	0

12 39 Gio 14 JUL 12°C	<b>System info</b>	1.2 bar	12 39 Gio 14 JUL 12°C	<b>System info</b>	1.2 bar	12 39 Gio 14 JUL 12°C	<b>System info</b>	1.2 bar
	Comfort	0		Alarm 1	E040		Next legionella	0
	Sun on	0		Alarm 2	E041		Rsc	1289
	Pcb id	GP02		Alarm 3	E077		Rs	8
	Pcb fw	7		Alarm 4	E010		Rss	1260
	Interface fw	2.1.76		Alarm 5	E077		Rf	104
	Radio signal	0		Clean exchanger	0			

INFO NAME	DESCRIPTION (only info related to the model configuration will be displayed)
SCREED HEATING HOURS	Number of hours spent with screed heater function (when in progress)
FLOW PROBE	Boiler flow sensor value
RETURN PROBE	Boiler return temperature sensor value
DHW PROBE	NOT AVAILABLE ON THIS MODEL
DHW SET	NOT AVAILABLE ON THIS MODEL
EXHAUST PROBE	Flue gas probe value
OUTDOOR TEMP PROBE	Instantaneous outdoor temperature sensor value
FILTERED OUTDOOR TEMP	Filtered outdoor temperature sensor value used in the temperature control algorithm to calculate the heating setpoint
DHW FLOW RATE	NOT AVAILABLE ON THIS MODEL
FAN SPEED	Number of fan rotations (rpm)
EXHAUST PROBE HOURS	Number of operating hours of the heat exchanger in "condensing mode" (the values are expressed in hundreds of hours, example: 01 = 100h)
MAIN ZONE SET	Main zone delivery setpoint
OT MAIN ZONE SET	Main zone delivery setpoint from OT+
WATER PRESSURE	System pressure
DHW HOUR	NOT AVAILABLE ON THIS MODEL
CH HOUR	Hours with burner on in heating mode
DHW MODULATION	NOT AVAILABLE ON THIS MODEL
CH MODULATION	Average modulation percentage value with burner on in heating mode
CH SUPPLY SENSOR AVG	Average flow sensor values with burner on in heating mode
DHW SUPPLY SENSOR AVG	NOT AVAILABLE ON THIS MODEL
CH RETURN SENSOR AVG	Average return probe values with burner on in heating mode
DHW RETURN SENSOR AVG	NOT AVAILABLE ON THIS MODEL
GAS VALVE ON CYCLES	Number of gas valve ON cycles
HIGH EFFICIENCY	If it is set to 1, it indicates the need for a drain-trap check for filling
COMFORT	NOT AVAILABLE ON THIS MODEL
SUN ON	NOT AVAILABLE ON THIS MODEL
PCB ID	Type of board connected
PCB FW	Firmware revision of the electronic board
INTERFACE FW	Interface firmware overhaul
RADIO SIGNAL	Indicates the quality of the WiFi connection
HISTORICAL ALARM 1 (oldest)	List of the last 5 alarms recorded
HISTORICAL ALARM 2	
HISTORICAL ALARM 3	
HISTORICAL ALARM 4	
HISTORICAL ALARM 5 (most recent)	
CLEAN HT EXCHANGER	Number of days since the CALL SERVICE alert was active
NEXT LEGIONELLA FUNCTION	Days missing until the next anti-legionella. NOT AVAILABLE ON THIS MODEL
RSC	Overhaul of Fw comfort extension
RS	Overhaul of Fw safety
RSS	Overhaul of Fw safety extension
RF	Overhaul of Fw fan

## 8. USER INSTRUCTIONS

- Turn the main system switch ON.
- Open the gas tap to allow the flow of fuel.

To set Time and Date, Buzzer and Language follow the instructions below:



- It then starts the automatic vent cycle, if enabled, lasting 4 min (for details see section section 5.8).
- The interface then shows that it was active in that moment.



Set the room thermostat to the desired temperature or, if the system is equipped with a chronothermostat or time programmer, check that it is 'on' and set.

- Then switch the boiler to WINTER.

### 8.1 TIME BAND SCHEDULING FUNCTION (ROOM THERMOSTAT)

**NOTE:** *The embedded clock might not be suitable for use with systems that incorporate different zones and/or circuits.*

If the heating system is managed by a room thermostat, and therefore has no time programming, the time programming can be enabled by the installer. Once the function has been enabled, the user has the possibility of managing the heating in the different time slots as indicated below.



The touch screen shows the preset programming:  
from MON to FRI: 07:30÷08:30 / 12:00÷13:30 / 18:00÷22:30

from SAT to SUN: 08:00÷22:30

It is possible to change the start and end times of a time slot by touching the time slot you wish to change; it is possible to add a time slot by clicking on the "+ add time slot" button before or after an existing slot, or delete a slot by clicking on the "- delete slot" button. It is possible to insert up to a maximum of 4 non-overlapping time bands.

Using the COPY and PASTE buttons it is possible to transfer the programming of one cluster (example Monday - Friday) to another (example Saturday).

### 8.2 OPERATING MODE

Some icons may be active depending on which settings are currently active

Stand by	Boiler mode	Winter	Summer*	Off
			<b>*NOT AVAILABLE ON THIS MODEL</b>	

### 8.3 HEATING SETPOINT SETTING

By clicking on the temperature value, you can directly access screens 1 and 2 to change the heating and DHW setpoint setting.

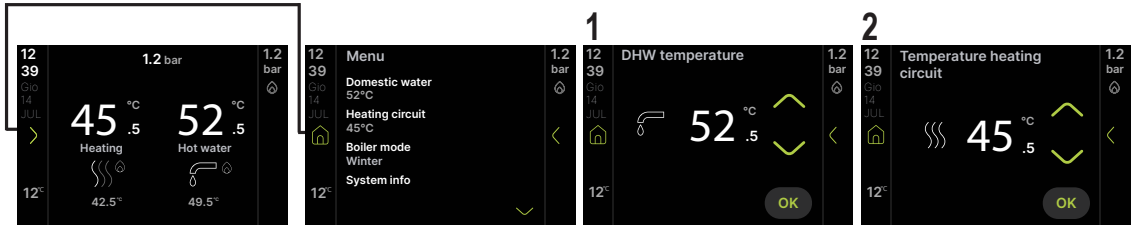

### 8.4 HEATING SETPOINT SETTING WITH OUTDOOR TEMPERATURE SENSOR

Only connect the Vokera external sensor if there is no requirement for HW. With an outdoor temperature sensor connected (optional) and thermoregulation enabled (see section 5.10), the delivery temperature value is automatically chosen by the system, which quickly adjusts the ambient temperature according to changes in the outdoor temperature.

#### Modification of the heating setpoint

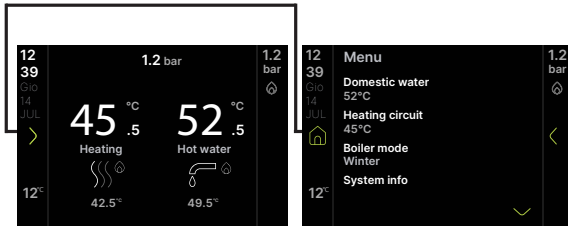

By clicking on the temperature value, you can directly access screens 1 and 2 to correct the value

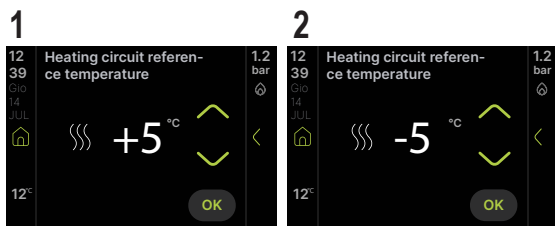

The setpoint correction is in the range (-5 ÷ +5 °C).

### 8.5 SAFETY STOP

In the event of ignition or operating faults, the boiler will perform a 'SAFETY STOP' and the display shows the error detected. For details see section 5.18.

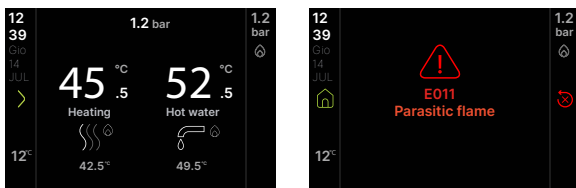

Pressing the symbol resets an ongoing fault. Contact the Technical Assistance Centre if unlocking attempts fail to reactivate regular operation.

### 8.6 TEMPORARY SHUT-DOWN

In the event of temporary absences (weekends, short breaks, etc.) set the status of the boiler to OFF.

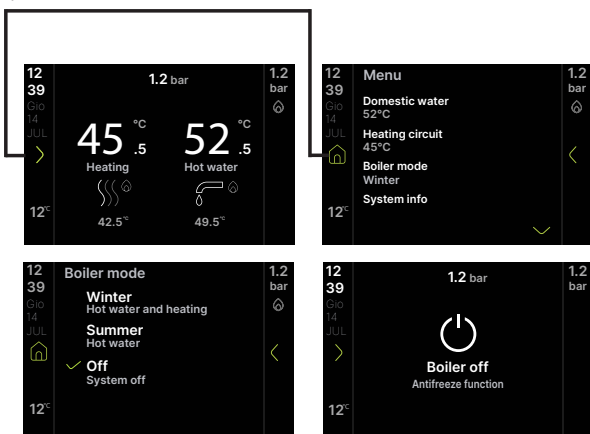

While the electrical supply and the fuel supply remain active, the system is protected by the following functions:

- **heating anti-freeze:** the function starts if the temperature detected by the flow sensor falls below 5°C. In this phase a heat request is generated with burner ignition at minimum output, which is maintained until the water delivery temperature reaches 35°C; the display shows "Heating antifreeze function in progress"
- **anti-lockout circulator:** the circulator is activated every 24 hours for a stop period of 30 seconds.

### 8.7 SWITCHING OFF FOR LONG PERIODS

If the boiler is not used for a long period of time, the following operations must be carried out:

- set the system to OFF
- set the main system switch to "off"
- turn off the fuel and water taps of the heating and domestic hot water system.

In this case, the anti-freeze and anti-locking systems are deactivated. Drain the heating and domestic water system if there is any risk of freezing.

### 8.8 KEYPAD LOCKOUT FUNCTION

To lock the keys

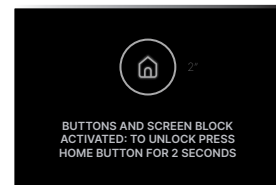

In the presence of a fault, the RESET key remains active to allow the alarm to be reset.

### 8.9 ALARM HISTORY

The alarm history can be activated from the TECHNICAL MENU.

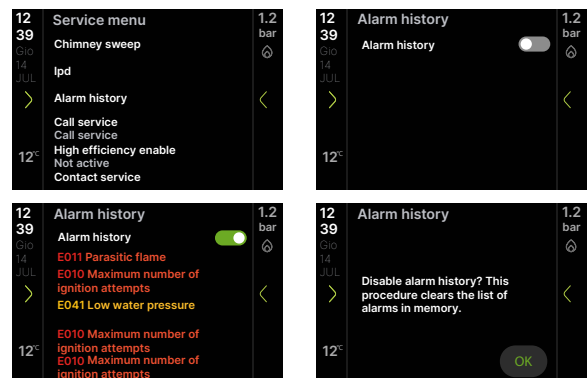

From the "System Info" menu a chronological order can be displayed, from the oldest (Alarm History 1) to the most recent (Alarm History 5), up to a maximum of 5.

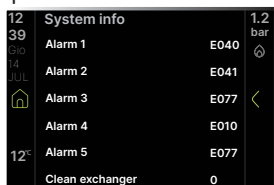

If an alarm occurs several times consecutively, it is saved only once.

To reset the alarm, follow the indications given in paragraph section 8.5.

## 8.10 CONNECTIVITY MENU

Before connecting 'Hi, Comfort T300 or K100' devices, the Connectivity Menu must be set up correctly to avoid communication failure problems, as shown below.

Remote management of the boiler can take place via:

### - Wi-Fi key

When the Wi-Fi key (Hi, Comfort K100) is connected, the backlit Wi-Fi button lights up.

In the "System Info" the radio signal strength can be displayed; if the Wi-Fi icon blinks, it means there is no connection to the cloud.

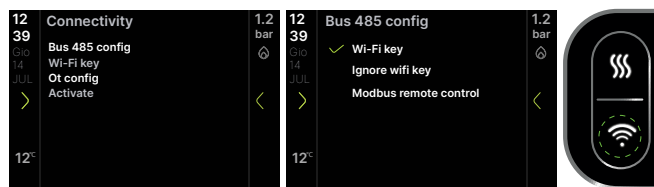

or

### - Modbus remote control (Hi, Comfort T300)

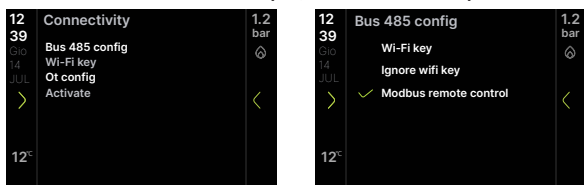

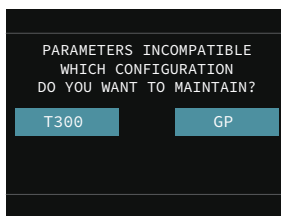

 Even when Hi, Comfort T300 is connected, the boiler interface continues to operate. It is possible to change the value of certain parameters either from the T300 or from the boiler interface. In the latter case Hi, Comfort T300 may report PARAMETERS INCOMPATIBLE message: choose the T300 option to restore the previous value of the changed parameter or GP to confirm the change made.

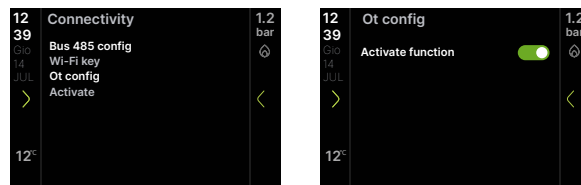

**Note:** the parameters for the BUZZER and COMBUSTION CONTROL functions cannot be modified by the T300.

It is also possible to activate remote management via an **OpenTherm chronothermostat:**



 The Hi, Comfort T300 and K100 remote controls cannot be connected to the boiler at the same time, however they can coexist with the T100 remote control if taken individually.

**Note:** the T100 remote control cannot be connected to the boiler if the system is hybrid (presence of a heat pump).

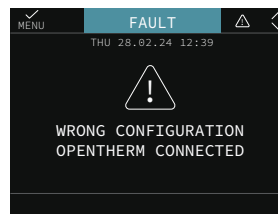

## 8.11 BIBERON FUNCTION

ONLY AVAILABLE ON COMBI BOILER.

## 9. GUIDED TOUR

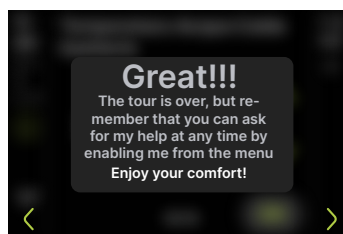
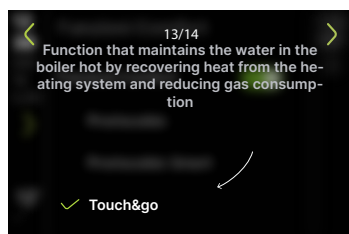
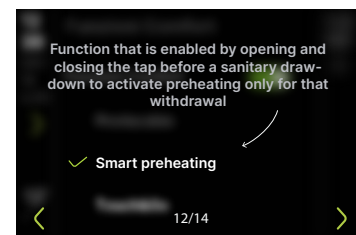
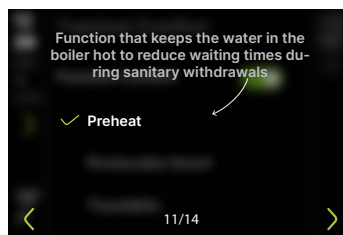
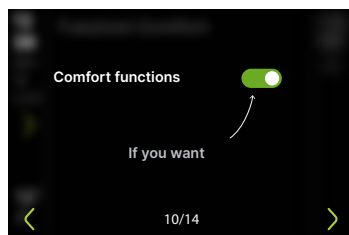
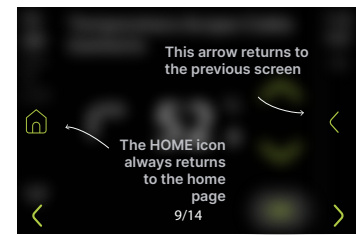
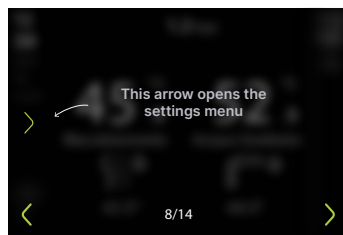
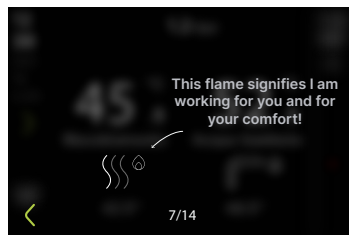
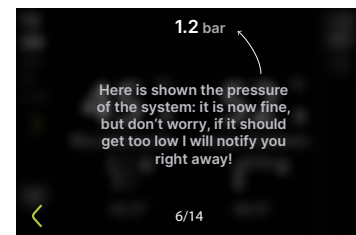
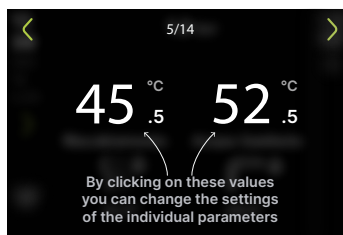
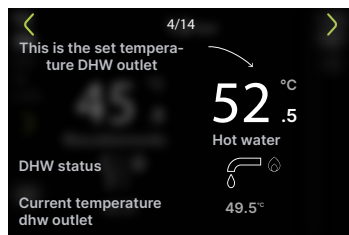
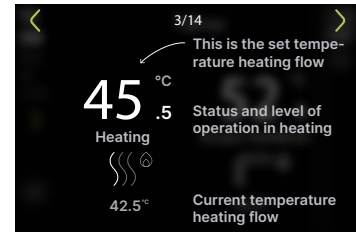
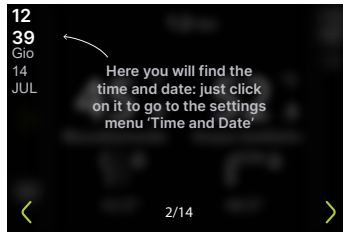
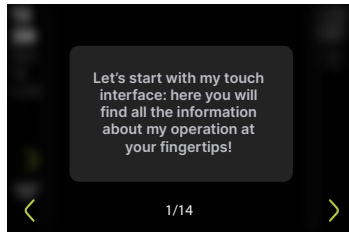
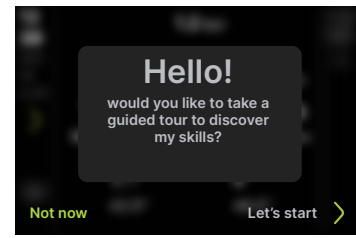
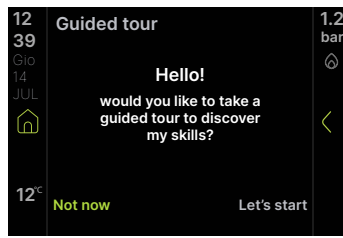
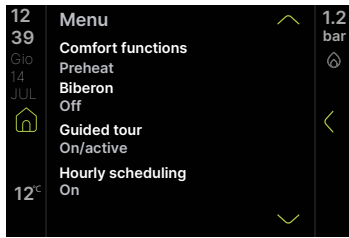

## 10. SECTION - SERVICING INSTRUCTIONS

### GENERAL

Once the appliance has been serviced, the benchmark Service Record must be completed.

#### For UK only

It is important that the Benchmark Service Record is correctly completed and handed to the user. Failure to install and commission the appliance to the manufacturers instructions will invalidate the warranty.

To ensure the continued safe and efficient operation of the appliance, it is recommended that it is checked and serviced at regular intervals. To ensure correct and safe operation of the appliance, it is essential that any worn or failed component be replaced only with a **genuine Vokèra spare part**. It should be remembered that although certain generic components may look similar, they will be specific to an individual appliance or product range. Use of non-genuine Vokèra spare parts could invalidate your warranty and may pose a potential safety hazard. The frequency of servicing will depend upon the particular installation conditions, but in general, once per year should be sufficient. It is the law that any servicing work is carried out by competent person such as a Vokèra engineer, an approved service agent, British Gas, GAS SAFE registered personnel or other suitably qualified personnel. The following instructions apply to the appliance and its controls, but it should be remembered that the central heating and the domestic hot water systems would also require attention from time to time.

### ROUTINE ANNUAL MAINTENANCE

The appliance incorporates many 'state-of-the-art' components that are either 'solid-state' or are regarded as 'non-serviceable' items. As a consequence, the requirements for routine annual maintenance are focussed upon:

1. ensuring that the appliance and flue system are in a safe condition
2. ensuring that the appliance is operating safely
3. ensuring that the appliance is performing to its design specification.

When the appliance has been installed to within the minimum stated clearances; the appliance layout is such that it enables routine annual maintenance to be carried out entirely from the front of the appliance.

#### NOTE

Any noticeable defect or deterioration on or within the appliance and flue system that impacts or affects the above requirements; will warrant further diagnosis and repair, which may result in the replacement of components.

Specific advice and instruction on the removal and replacement of component parts of the appliance can be found online using the adjacent QR code or by visiting our website.

### ROUTINE ANNUAL MAINTENANCE REQUIREMENTS

1. Check the operation of the appliance in both the heating and hot water modes and ensure the performance is in line with the appliance specification.
2. Using the UI menu, navigate to the alarms history and check for any recent alarm events.  
Refer to the alarm/fault codes description chart for further information.
3. Remove the front cover (see section 4.5) and visually inspect the internal components and electrical wiring for any defect or deterioration.
4. Visually check for any dirt or debris within the condensate trap (the trap is translucent and can be checked visually).
5. Replace the front cover as detailed in section 4.5 taking notice of the importance of ensuring that the effectiveness of the – front cover – seals are not compromised.
6. Carry out a combustion analysis as detailed in section 5.14.
7. Visually check the entire flue system for any damage, defect, or deterioration.

#### NOTE

In order to access the 'alarms history' it is necessary to access the password protected settings. Refer to section 7 for further details.

### UNSCHEDULED MAINTENANCE

The appliance incorporates software that monitors the operating conditions of the appliance, and will record any 'unusual usage conditions' that will affect the requirement to remove and clean the burner/heat exchanger assembly. When the 'unusual usage' hours reach a pre-determined threshold, the appliance will signal – via alarm code E091 – that the heat exchanger requires to be cleaned.

### REPLACEMENT OF COMPONENTS

Although it is anticipated that this appliance will provide years of trouble-free service and outstanding performance; the lifespan of any component will be determined by factors such as operating conditions and usage levels. Should the appliance develop a fault, the fault-finding section of this manual will greatly assist in determining the cause; however further advice can be sought from the Vokera Technical Help-line. Remember always to use only genuine Vokera spare parts.

### COMPONENT REMOVAL PROCEDURE

To remove/replace a component, access to the interior of the appliance is usually essential.

**Always** isolate the appliance from the electrical supply – and if necessary remove the fuse.

- Close all service valves if any hydraulic and/or gas carrying item is to be removed.
- Remove the front cover – and where necessary or convenient – the side panels of the appliance as detailed in 4.5.
- If required, drain the primary circuit via the drain valve (located adjacent to the diverter valve) using the tubing supplied with the appliance.
- If required, drain the secondary circuit via the available DHW outlets.

#### NOTE

When removing a hydraulic component, ensure that some water absorbent cloths are available to catch any residual water that may drip from the appliance and/or the removed component.

When the appliance has been installed to within the stated minimum clearances; it may be necessary to remove adjacent components in order to facilitate access to a specific component.

Carry out the relevant elements of the commissioning procedure (section 5) after replacing a component.

**ALWAYS TEST FOR GAS TIGHTNESS IF ANY GAS CARRYING COMPONENT HAS BEEN DISTURBED, REMOVED, OR REPLACED.**

**WHEN REPLACING THE SIDE PANELS AND/OR THE FRONT COVER, ENSURE THE ROOM SEALED INTEGRITY OF THE APPLIANCE HAS NOT BEEN COMPROMISED – REFER TO 4.5.**

To obtain detailed specific information and instructions on how to remove and replace specific components, please access our online resources by logging on to our website.

[www.vokera.co.uk](http://www.vokera.co.uk)  
[www.vokera.ie](http://www.vokera.ie)



## 11. SECTION - CHECKS, ADJUSTMENTS AND FAULT FINDING

**NOTE:** please refer to section 3, section 3.1 and use the appropriate PPE when carrying out any of the actions or procedures contained within this section.

### 11.1 CHECKING APPLIANCE OPERATION

When carrying out any repairs or servicing to the appliance, the relevant commissioning procedure must be undertaken to ensure the continued safe operation of the appliance. Particular attention should be made to ensure gas tightness, water tightness and the electrical integrity of the appliance.

### 11.2 APPLIANCE MODES OF OPERATION

**NOTE:** there must be sufficient system water pressure (min. 0.4 bar) to ensure the water pressure switch is activated. If there is insufficient system pressure the pump and fan will be prevented from operating and the low-pressure fault code will be indicated.

#### 11.2.1 OFF

When the appliance has been set to OFF via the UI, the following functions will remain active:

- frost-protection system
- pump & actuator anti-block.

#### 11.2.2 ON-BOARD FUNCTIONS

- **FROST-PROTECTION:** this function is only active when there are no requests for heating or HW. If the temperature drops below 5°C, the boiler will operate on minimum power until the temperature of the thermistors reaches 35°C for CH and 55°C for DHW. Thereafter the pump & fan will over-run for 30-seconds.
- **ANTI-CYCLE FUNCTION:** the anti-cycle function ensures the burner remains switched off for at least 3-minutes after the set-point hysteresis (set-point + 5-deg) for CH heat request.
- **PUMP ANTI-BLOCK FUNCTION:** when there has been no heating or HW request for 24-hours, the anti-block cycle is activated. The pump will be activated for a period of 30-seconds.

#### 11.2.3 HEATING MODE

When a 'heating' request is generated via the connected external control/s and/or the UI, the appliance will operate in the heating mode. The pump and fan will be activated via the flow temperature sensor. When the fan is sensed to be operating correctly (tacho signal), the ignition sequence commences. Ignition is sensed by the electronic circuit to ensure flame stability at the burner. Once successful ignition has been achieved, the electronic circuitry increases the gas rate to 75% for a period of 15 minutes.

The speed of the fan and therefore the output of the boiler is determined by the temperature of the water sensed by the flow temperature sensor, consequently a high temperature at the flow sensor results in a lower fan speed. As the water temperature increases, the temperature sensors – located on the flow pipe of the boiler – reduce the fan speed via the electronic circuitry. Depending on the load, either the water temperature will continue to rise until the set point is achieved or the water temperature will fall whereby fan speed will increase relative to the output required. When the boiler has reached the set point (+ hysteresis), the burner will switch off. The built-in anti-cycle device prevents the burner from re-lighting for approximately 3-minutes.

When the temperature of the flow sensor falls below the set point (- hysteresis), the burner will re-light.

**NOTE:** if burner ignition is not detected at the first attempt, the appliance will repeat the ignition sequence another two times (3-times in total) before going to lockout. When the set-point has been reached as measured at the primary thermistor, the appliance will begin the modulation phase whereby the fan and gas valve will continuously modulate to maintain the set-point. If the temperature continues to rise and exceeds the set-point by 5°C (hysteresis), the burner will shut down. A new ignition sequence will be enabled when the 3- minute anti-cycle has been performed and the temperature at the primary thermistor has dropped 5°C (hysteresis) below the set-point.

**NOTE:** when the request for heating and/or hot water has been satisfied, the appliance pump and fan may continue to circulate to dissipate any residual heat within the appliance.

#### ATTENTION

Gas type and appliance outputs are factory set by default, at the values declared in the specification data in section 2.

Vokera cannot accept any responsibility for any damage or malfunction that has been caused as a result of tampering or incorrect set up of this appliance during installation or commissioning.

### 11.3 CHECKING THE EXPANSION VESSEL

Carry out the component removal procedure. You must ensure that the boiler is completely drained of water. Using a suitable pressure gauge, remove dust cap on expansion vessel and check the charge pressure. The correct charge pressure should be 1.0 bar ± 0.1 bar. If the charge pressure is less, use a suitable pump to increase the charge.

**NOTE:** you must ensure the drain valve is in the open position whilst re-charging takes place. Replace the dust cap and carry out the relevant commissioning procedure (section 5).

### 11.4 EXTERNAL FAULTS

Before carrying out any faultfinding or component replacement, ensure the fault is not attributable to any aspect of the installation.

#### 11.4.1 INSTALLATION FAULTS

Symptom	Possible cause
No ignition	Check wiring/check electrical supply/ check gas supply
No hot water	Check external controls
No heating	Check external controls

Fault	Possible cause
Fault code	Check gas supply, check flue system

### 11.5 ELECTRICAL CHECKS

Any electrical checks must be carried out by a suitably qualified person.

#### 11.5.1 EARTH CONTINUITY TEST

Isolate the appliance from the electrical supply, and using a suitable multi-meter carry out a resistance test. Connect test leads between an appliance earth point and the earth wire of the appliance supply cable. The resistance should be less than 1 OHM. If the resistance is greater than 1 OHM check all earth wires and connectors for continuity and integrity.

#### 11.5.2 SHORT CIRCUIT CHECK

Isolate the appliance from the electrical supply, and using a suitable multi-meter, carry out a short circuit test between the Live & Neutral connections at the appliance terminal strip. Repeat above test on the Live & Earth connections at the appliance terminal strip.

#### NOTE

Should it be found that the fuse has failed but no fault is indicated, a detailed continuity check will be required to trace the fault. A visual inspection of components may also assist in locating the fault.

#### 11.5.3 POLARITY CHECK

With the appliance connected to the electrical supply and using a suitable multimeter, carry out the following voltage tests:

- connect test leads between the Live & Neutral connections at the appliance terminal strip. The meter should read approximately 230V ac. If so proceed to next stage. If not, check electrical supply and fuses.
- connect test leads between the Live & Earth connections at the appliance terminal strip. The meter should read approximately 230V ac. If so proceed to next stage. If not, check wiring.
- connect test leads between the Neutral & Earth connections at the appliance terminal strip. The meter should read approximately 0 – 15Vac. If so polarity is correct. If not, see section 11.6.

#### 11.5.4 REVERSED POLARITY OR SUPPLY FAULT

Repeat the above tests at the appliance isolator, if testing reveals correct polarity and/or supply at the isolator, re-check wiring and connections between the isolator and the appliance. If tests on the isolator also reveal reversed polarity or a supply fault, consult the local electricity supplier for advice.

#### RESISTANCE TO EARTH

Isolate the appliance from the electrical supply, and using a suitable multi-meter carry out a resistance test. Connect test leads between the Live & Earth connections at the appliance terminal strip. If the meter reads other than infinity there is a fault that must be isolated, carry out a detailed continuity check to identify the location of the fault.

These series of checks must be carried out before attempting any faultfinding procedures on the appliance. On completion of any task that required the disconnection and re-connection of any electrical wiring or component, these checks must be repeated.

#### 11.6 FAULT FINDING

Before attempting any faultfinding, the electrical checks as detailed in section 11.5 must be carried out. Isolate the appliance from the electrical supply.

Disconnect any external controls from terminal plug, and insert a link-wire between the two wires at the 'TA' connections of the CE8 connector.

**NOTE:** restore the electrical supply to the boiler and RESET functioning. The boiler should now function as described in section 11.2. Should the boiler fail to respond, the internal fuses and connectors should be checked to ensure integrity and continuity.

#### 11.7 APPLIANCE STATUS AND FAULT CODES

When the boiler detects a temporary fault condition, the appropriate code is shown. If/when the fault is final, the pump will perform 30 to 60-second post circulation (depending on the error code) and fault code will be displayed. For combustion fault, FAN can also post vent up to 5min if required.

#### 11.8 TYPICAL HI-COMFORT CONNECTION – CONNECTED TO THE CE8 CONNECTOR

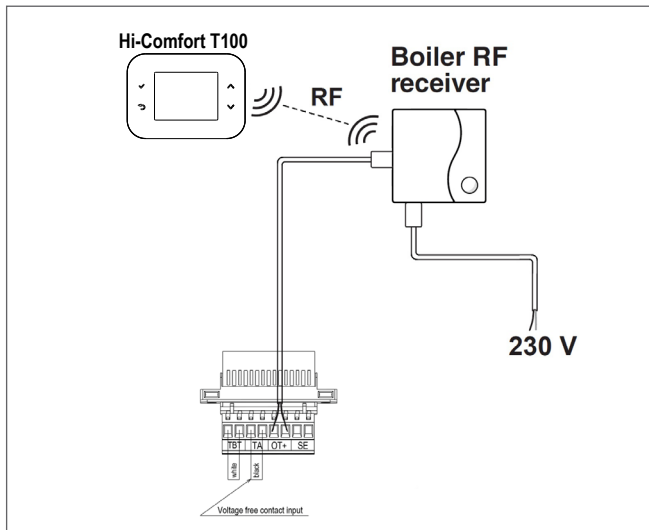

# FUNCTIONAL DIAGRAM

NOTA : L-N- E connection is advisable

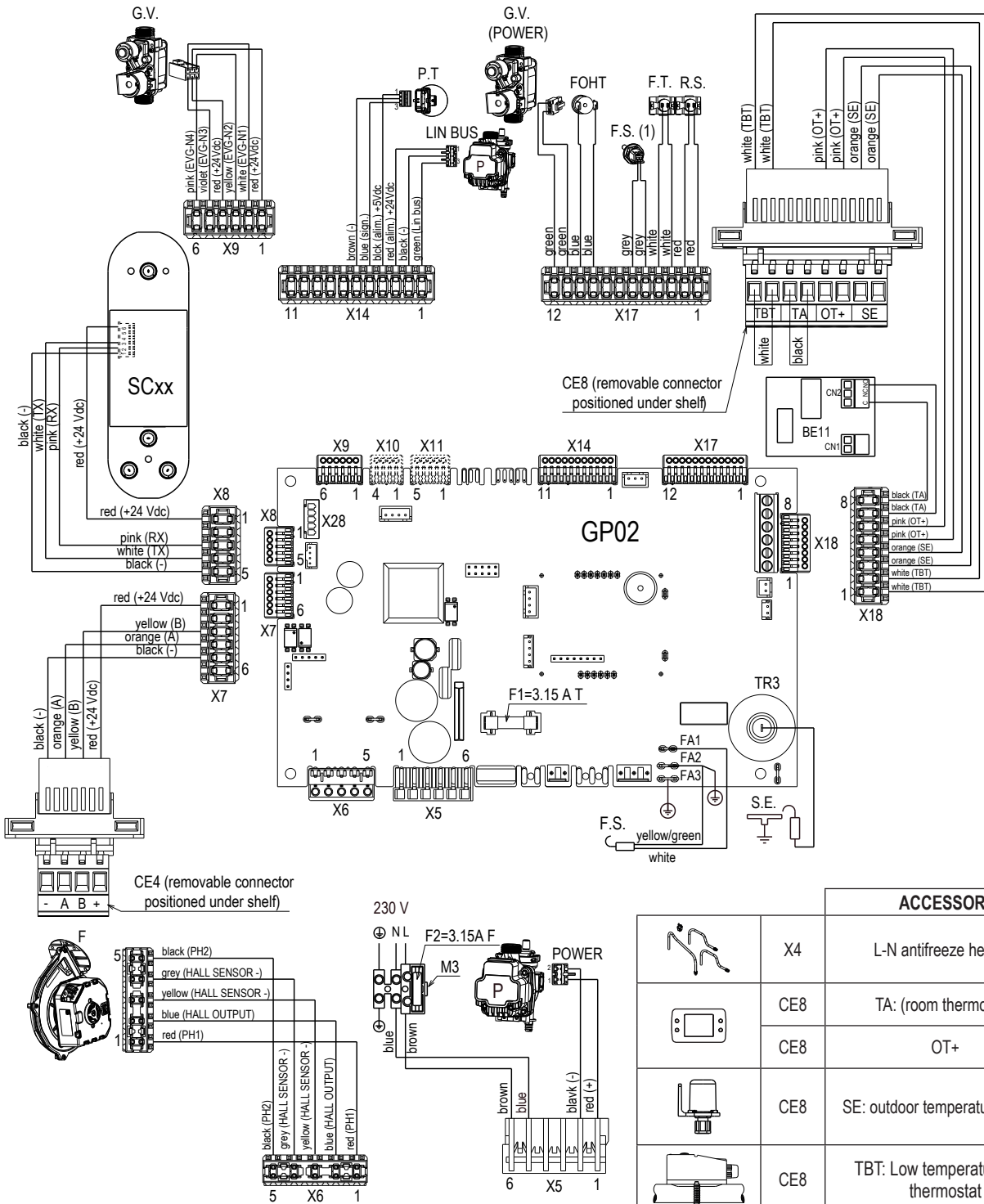

## ACCESSORIES

Icon	Code	Description
	X4	L-N antifreeze heaters
	CE8	TA: (room thermostat)
	CE8	OT+
	CE8	SE: outdoor temperature sensor
	CE8	TBT: Low temperature limit thermostat
	X10	Alarm remote control
	X11	Zone valve or additional pump

## Multiwire wiring diagram

**GP02:** Combustion regulation and control board  
**SCxx:** Control panel  
**BE11:** On board relè PCB (Room thermostat)  
**X1-X28:** Connection connectors (X10 - X11 accessories)  
**TR3:** Ignition transformer  
**F1:** Fuse 3.15A T  
**F2:** Fuse 3.15A F  
**F:** Fan 325 Vdc

**S.E.:** Spark electrode  
**F.S.:** Flame sensor  
**P.T.:** Pressure transducer  
**P (power):** Pump 325 Vdc  
**P (Lin Bus):** Lin Bus signal pump  
**M3:** Terminal strip for electrical connection high power  
**G.V.:** 24 Vdc stepper gas valve  
**G.V. (power):** 24 Vdc gas valve supply  
**F.S. (1):** Flue sensor  
**F.O.H.T.:** Flow over heat thermostat

**F.T.:** Flow thermistor  
**RS:** Return thermistor  
**CE4:** Connector for external connections: (- A B +) Bus 485  
**CE8:** Connector for external connections (accessories):  
**TBT:** Low temperature thermostat  
**TA:** Room thermostat (voltage free contact input)  
**OT+:** Open therm  
**SE:** Outdoor temperature sensor

## 12. SECTION - LPG INSTRUCTIONS

### 12.1 RELATED DOCUMENTS

BS 6798		INSTALLATION OF BOILERS OF RATED INPUT NOT EXCEEDING 60 kW
BS EN 12828		DESIGN FOR WATER-BASED HEATING SYSTEMS
BS 5446		INSTALLATION OF GAS HOT WATER SUPPLIES FOR DOMESTIC PURPOSES
BS 5440	PARTS 1 & 2	FLUES & VENTILATION
BS 6891		SPECIFICATION FOR THE INSTALLATION AND MAINTENANCE OF LOW PRESSURE GAS INSTALLATION PIPEWORK OF UP TO 35 mm

### 12.2 TECHNICAL DATA

Gas Pressures	PINNACLE 20S	PINNACLE 25S	PINNACLE 32S
Inlet pressure	37.0 mbar	37.0 mbar	37.0 mbar
Maximum gas rate (CH)	1.55 (kg/h)	1.94 (kg/h)	2.48 (kg/h)
Minimum gas rate (CH)	0.19 (kg/h)	0.27 (kg/h)	0.27 (kg/h)
Maximum number of heating fan rotations	6,100 (rpm)	5,800 (rpm)	7,500 (rpm)
Minimum number of heating fan rotations	1,250 (rpm)	1,250 (rpm)	1,250 (rpm)
Emissions	PINNACLE 20S	PINNACLE 25S	PINNACLE 32S
NOx (max-min)	50 - 50 p.p.m.	40 - 40 p.p.m.	40 - 40 p.p.m.
CO (max-min)	250 - 20 p.p.m.	250 - 20 p.p.m.	240 - 20 p.p.m.
CO <sub>2</sub> (max-min) *	10.0 - 10.0 %	9.9 - 10.0 %	9.9 - 10.0 %

(\* ) CO<sub>2</sub> tolerance= +1% -1%

### 12.3 APPLIANCE RE-CONFIGURATION FOR LPG

#### WARNING!

**The gas supply to the appliance must remain turned OFF until the following procedure has been completed.**

Refer to section 5.16 Gas Conversion and follow the step by step instructions. Once the gas conversion procedure has been completed, carry out a GAC procedure (section 5.9) and - if necessary - adjust to the appropriate fan speed/s found above and in section 5.15.

**NOTE:** the appliance gas valve is factory set and therefore non-adjustable. Do not attempt to adjust or interfere with the settings of the gas valve, as to do so, will cause the appliance to malfunction and may lead to serious damage.

The boiler DOES NOT require additional adjustments.



The boiler may only be converted by qualified staff.



**After conversion apply the LPG label to the appliance data plate (LPG label is contained within the documentation pack).**

# COMMISSIONING: CO AND COMBUSTION RATIO CHECK

## BEFORE CO AND COMBUSTION RATIO CHECK

The installation instructions should have been followed, gas type verified and gas supply pressure/rate checked as required prior to commissioning.

As part of the installation process, **ESPECIALLY WHERE A FLUE HAS BEEN FITTED BY PERSONS OTHER THAN THE BOILER INSTALLER**, visually check the integrity of the whole flue system to confirm that all components are correctly assembled, fixed and supported. Check that the maximum flue lengths have not been exceeded and all guidance has been followed (e.g. Technical Bulletin 008).

The flue gas analyser should be of the correct type, as specified by BS 7967.

Before use, the flue gas analyser should have been maintained and calibrated as specified by the manufacturer. The installer must have the relevant competence for use of the analyser.

Check and zero the analyser **IN FRESH AIR**, as per analyser manufacturer's instructions.

## NOTE

The air/gas ratio valve is factory-set and must not be adjusted during commissioning unless this action is recommended, following contact with the Vokera technical help line. If any such adjustment is recommended and further checking of the boiler is required, the engineer must be competent to carry out this work and to use the flue gas analyser accordingly. If the boiler requires conversion to operate with a different gas family (e.g., conversion from natural gas to LPG) separate guidance will be provided by the Vokera technical help line and must be followed.

## SET BOILER TO MAXIMUM RATE

In accordance with the commissioning procedure, i.e. 'combustion check', set the appliance to operate at maximum gas rate.

Allow sufficient time for combustion to stabilise, insert analyser probe into air inlet sampling point.

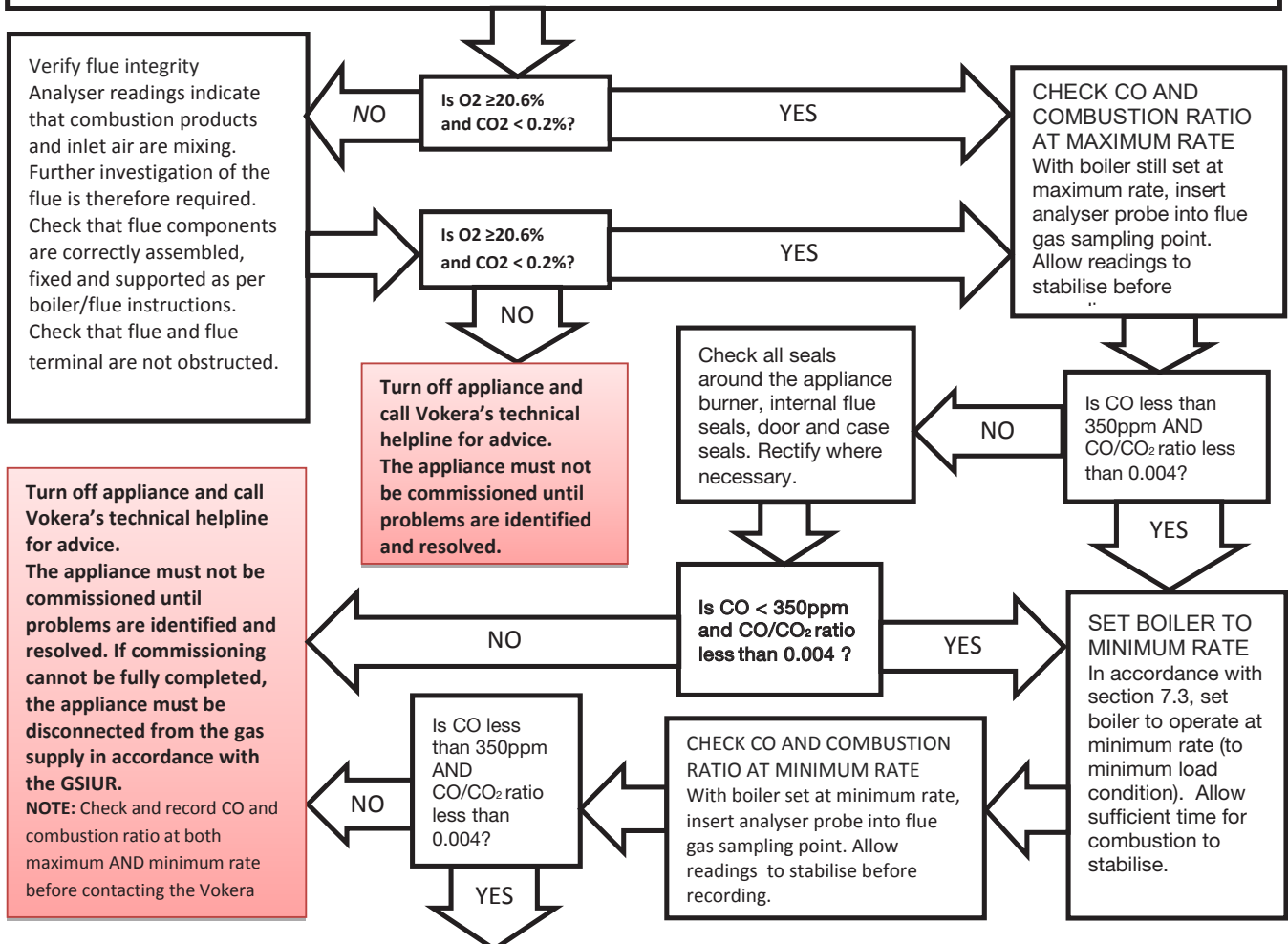

## Boiler is operating satisfactorily No further actions required.

Ensure test points are capped, boiler case is correctly replaced and all other commissioning procedures are completed. Complete Benchmark Checklist, recording CO and combustion ratio readings as required.

# Benchmark Commissioning & Warranty Validation Service Record

It is a requirement that the boiler is installed and commissioned to the manufacturers' instructions and the data fields on the commissioning checklist completed in full.

To instigate the boiler warranty the boiler needs to be registered with the manufacturer within one month of the installation. The warranty rests with the end-user (consumer), and they should be made aware it is ultimately their responsibility to register with the manufacturer, within the allotted time period.

It is essential that the boiler is serviced in line with the manufacturers' recommendations, at least annually. This must be carried out by a competent Gas Safe registered engineer. The service details should be recorded on the Benchmark Service and Interim Boiler Work Record and left with the householder. Failure to comply with the manufacturers' servicing instructions and requirements will invalidate the warranty.



[www.hhic.co.uk](http://www.hhic.co.uk)

**This Commissioning Checklist is to be completed in full by the competent person who commissioned the boiler as a means of demonstrating compliance with the appropriate Building Regulations and then handed to the customer to keep for future reference.**

Failure to install and commission according to the manufacturers' instructions and complete this Benchmark Commissioning Checklist will invalidate the warranty. This does not affect the customer's statutory rights.

All installations in England and Wales must be notified to Local Authority Building Control (LABC) either directly or through a competent Persons Scheme. A Building Regulations Compliance Certificate will then be issued to the customer.

Heating and Hotwater Industry Council (HHIC)



[www.centralheating.co.uk](http://www.centralheating.co.uk)

## GAS BOILER SYSTEM COMMISSIONING CHECKLIST & WARRANTY VALIDATION RECORD

Address:															
Boiler make and model:															
Boiler serial number:															
Commissioned by (PRINT NAME):						Gas Safe registration number:									
Company name:						Telephone number:									
Company email:						Company address:									
										Commissioning date:					
Heating and hot water system complies with the appropriate Building Regulations?											Yes				
Optional: Building Regulations Notification Number (if applicable):															
Time, temperature control and boiler interlock provided for central heating and hot water											Yes				
Boiler Plus requirements (tick the appropriate box(s))															
Boiler Plus option chosen for combination boiler in ENGLAND						Weather compensation			Smart thermostat with automisation and optimisation						
						Load compensation			Flue Gas Heat Recovery						
Time and temperature control to hot water			Cylinder thermostat and programmer/timer						Combination boiler						
Zone valves			pre-existing			Fitted			Not required						
Thermostatic radiator valves			pre-existing			Fitted			Not required						
Automatic bypass to system			pre-existing			Fitted			Not required						
Underfloor heating			pre-existing			Fitted			Not required						
Water quality															
The system has been flushed, cleaned and a suitable inhibitor applied upon final fill, in accordance with BS7593 and boiler manufacturers' instructions											Yes				
What system cleaner was used?						Brand:			Product:						
What inhibitor was used?						Brand:			Product:						
Primary water system filter			pre-existing			Fitted			Not required						
CENTRAL HEATING MODE measure and record (as appropriate)															
Gas rate (for combination boilers complete DHW mode gas rate)						m <sup>3</sup> /hr			or			ft <sup>3</sup> /hr			
Central heating output left at factory settings?						Yes			No						
If no, what is the maximum central heating output selected?												kW			
Dynamic gas inlet pressure												mbar			
Central heating flow temperature												°C			
Central heating return temperature												°C			
System correctly balanced/rebalanced?						Yes									
COMBINATION BOILERS ONLY															
Is the installation in a hard water area (above 200ppm)?						Yes			No						
Water scale reducer/softener			pre-existing			Fitted			Not required						
What type of scale reducer/softener has been fitted?						Brand:			Product:						
Water meter fitted?						Yes			No						
If yes- DHW expansion vessel			pre-existing			Fitted			Not required						
Pressure reducing valve			pre-existing			Fitted			Not required						
DOMESTIC HOT WATER MODE Measure and record															
Gas rate						m <sup>3</sup> /hr			or			ft <sup>3</sup> /hr			
Dynamic gas inlet pressure at maximum rate												mbar			
Cold water inlet temperature												°C			
Hot water has been checked at all outlets						Yes			Temperature			°C			
CONDENSATE DISPOSAL															
The condensate drain has been installed in accordance with the manufacturers' instructions and/or BS5546/BS6798											Yes				
Point of termination						Internal			External (only where internal termination impractical)						
Method of disposal						Gravity			Pumped						
ALL INSTALLATIONS															
Record the following		At max rate:		CO		ppm		CO <sub>2</sub>		%		CO/CO <sub>2</sub>		Ratio	
		At min rate (where possible)		CO		ppm		CO <sub>2</sub>		%		CO/CO <sub>2</sub>		Ratio	
Where possible, has a flue integrity check been undertaken in accordance with manufacturers' instructions, and readings are correct?											Yes				
The operation of the boiler and system controls have been demonstrated to and understood by the customer											Yes				
The manufacturers' literature, including Benchmark Checklist and Service Record, has been explained and left with the customer											Yes				
Commissioning Engineer's signature															
Customer's signature (To confirm satisfactory demonstration and receipt of manufacturers' literature)															

\* All installations in England and Wales must be notified to Local Authority Building Control (LABC) either directly or through a Competent Persons Scheme. A Building Regulations Compliance Certificate will then be issued to the customer.

© Heating and Hotwater Industry Council (HHIC)



www.centralheating.co.uk

# SERVICE & INTERIM BOILER WORK RECORD

It is recommended that your boiler and heating system are regularly serviced and maintained, in line with manufacturers' instructions, and that the appropriate service / interim work record is completed.

## Service provider

When completing a service record (as below), please ensure you have carried out the service as described in the manufacturers' instructions. Always use the manufacturers specified spare parts.

<b>SERVICE/INTERIM WORK ON BOILER</b> delete as appropriate					Date:	
Engineer name:		Company name:				
Telephone N°:		Gas Safe registration N°:				
Max rate	CO	ppm	CO <sub>2</sub>	%	CO/CO <sub>2</sub>	
Min rate	CO	ppm	CO <sub>2</sub>	%	CO/CO <sub>2</sub>	
Where possible, has a flue integrity check been undertaken in accordance with manufacturers' instructions, and readings are correct?*					yes	
Gas rate:	m <sup>3</sup> /h	OR	ft <sup>3</sup> /h			
Were parts fitted? <sup>delete as appropriate</sup>	Yes	No				
Parts fitted:						
System inhibitor concentration has been checked and appropriate action taken, in accordance with BS 7593 and boiler manufacturers' instructions. *					yes	n/a
Comments:						
Signature:						

\*A System inhibitor efficacy test is required on every annual service in accordance with the manufacturers' instructions and BS 7593. It is only acceptable to not have undertaken this if the service engineers attendance visit was in between annual services to attend a non-water facing component.

<b>SERVICE/INTERIM WORK ON BOILER</b> delete as appropriate					Date:	
Engineer name:		Company name:				
Telephone N°:		Gas Safe registration N°:				
Max rate	CO	ppm	CO <sub>2</sub>	%	CO/CO <sub>2</sub>	
Min rate	CO	ppm	CO <sub>2</sub>	%	CO/CO <sub>2</sub>	
Where possible, has a flue integrity check been undertaken in accordance with manufacturers' instructions, and readings are correct?*					yes	
Gas rate:	m <sup>3</sup> /h	OR	ft <sup>3</sup> /h			
Were parts fitted? <sup>delete as appropriate</sup>	Yes	No				
Parts fitted:						
System inhibitor concentration has been checked and appropriate action taken, in accordance with BS 7593 and boiler manufacturers' instructions. *					yes	n/a
Comments:						
Signature:						

\*A System inhibitor efficacy test is required on every annual service in accordance with the manufacturers' instructions and BS 7593. It is only acceptable to not have undertaken this if the service engineers attendance visit was in between annual services to attend a non-water facing component.

<b>SERVICE/INTERIM WORK ON BOILER</b> delete as appropriate					Date:	
Engineer name:		Company name:				
Telephone N°:		Gas Safe registration N°:				
Max rate	CO	ppm	CO <sub>2</sub>	%	CO/CO <sub>2</sub>	
Min rate	CO	ppm	CO <sub>2</sub>	%	CO/CO <sub>2</sub>	
Where possible, has a flue integrity check been undertaken in accordance with manufacturers' instructions, and readings are correct?*					yes	
Gas rate:	m <sup>3</sup> /h	OR	ft <sup>3</sup> /h			
Were parts fitted? <sup>delete as appropriate</sup>	Yes	No				
Parts fitted:						
System inhibitor concentration has been checked and appropriate action taken, in accordance with BS 7593 and boiler manufacturers' instructions. *					yes	n/a
Comments:						
Signature:						

\*A System inhibitor efficacy test is required on every annual service in accordance with the manufacturers' instructions and BS 7593. It is only acceptable to not have undertaken this if the service engineers attendance visit was in between annual services to attend a non-water facing component.

<b>SERVICE/INTERIM WORK ON BOILER</b> delete as appropriate					Date:	
Engineer name:		Company name:				
Telephone N°:		Gas Safe registration N°:				
Max rate	CO	ppm	CO <sub>2</sub>	%	CO/CO <sub>2</sub>	
Min rate	CO	ppm	CO <sub>2</sub>	%	CO/CO <sub>2</sub>	
Where possible, has a flue integrity check been undertaken in accordance with manufacturers' instructions, and readings are correct?*					yes	
Gas rate:	m <sup>3</sup> /h	OR	ft <sup>3</sup> /h			
Were parts fitted? <sup>delete as appropriate</sup>	Yes	No				
Parts fitted:						
System inhibitor concentration has been checked and appropriate action taken, in accordance with BS 7593 and boiler manufacturers' instructions. *					yes	n/a
Comments:						
Signature:						

\*A System inhibitor efficacy test is required on every annual service in accordance with the manufacturers' instructions and BS 7593. It is only acceptable to not have undertaken this if the service engineers attendance visit was in between annual services to attend a non-water facing component.

<b>SERVICE/INTERIM WORK ON BOILER</b> delete as appropriate					Date:	
Engineer name:		Company name:				
Telephone N°:		Gas Safe registration N°:				
Max rate	CO	ppm	CO <sub>2</sub>	%	CO/CO <sub>2</sub>	
Min rate	CO	ppm	CO <sub>2</sub>	%	CO/CO <sub>2</sub>	
Where possible, has a flue integrity check been undertaken in accordance with manufacturers' instructions, and readings are correct?*					yes	
Gas rate:	m <sup>3</sup> /h	OR	ft <sup>3</sup> /h			
Were parts fitted? <sup>delete as appropriate</sup>	Yes	No				
Parts fitted:						
System inhibitor concentration has been checked and appropriate action taken, in accordance with BS 7593 and boiler manufacturers' instructions. *					yes	n/a
Comments:						
Signature:						

\*A System inhibitor efficacy test is required on every annual service in accordance with the manufacturers' instructions and BS 7593. It is only acceptable to not have undertaken this if the service engineers attendance visit was in between annual services to attend a non-water facing component.

<b>SERVICE/INTERIM WORK ON BOILER</b> delete as appropriate					Date:	
Engineer name:		Company name:				
Telephone N°:		Gas Safe registration N°:				
Max rate	CO	ppm	CO <sub>2</sub>	%	CO/CO <sub>2</sub>	
Min rate	CO	ppm	CO <sub>2</sub>	%	CO/CO <sub>2</sub>	
Where possible, has a flue integrity check been undertaken in accordance with manufacturers' instructions, and readings are correct?*					yes	
Gas rate:	m <sup>3</sup> /h	OR	ft <sup>3</sup> /h			
Were parts fitted? <sup>delete as appropriate</sup>	Yes	No				
Parts fitted:						
System inhibitor concentration has been checked and appropriate action taken, in accordance with BS 7593 and boiler manufacturers' instructions. *					yes	n/a
Comments:						
Signature:						

\*A System inhibitor efficacy test is required on every annual service in accordance with the manufacturers' instructions and BS 7593. It is only acceptable to not have undertaken this if the service engineers attendance visit was in between annual services to attend a non-water facing component.

\* All installations in England and Wales must be notified to Local Authority Building Control (LABC) either directly or through a Competent Persons Scheme. A Building Regulations Compliance Certificate will then be issued to the customer.

© Heating and Hotwater Industry Council (HHIC)



www.centralheating.co.uk



# SERVICE & INTERIM BOILER WORK RECORD

It is recommended that your boiler and heating system are regularly serviced and maintained, in line with manufacturers' instructions, and that the appropriate service / interim work record is completed.

## Service provider

When completing a service record (as below), please ensure you have carried out the service as described in the manufacturers' instructions. Always use the manufacturers' specified spare parts.

SERVICE/INTERIM WORK ON BOILER <small>delete as appropriate</small>					Date:
Engineer name:		Company name:			
Telephone N°:		Gas Safe registration N°:			
Max rate	CO	ppm	CO <sub>2</sub>	%	CO/CO <sub>2</sub>
Min rate	CO	ppm	CO <sub>2</sub>	%	CO/CO <sub>2</sub>
Where possible, has a flue integrity check been undertaken in accordance with manufacturers' instructions, and readings are correct?"					yes
Gas rate:	m <sup>3</sup> /h	OR	ft <sup>3</sup> /h		
Were parts fitted? <small>delete as appropriate</small>		Yes	No		
Parts fitted:					
System inhibitor concentration has been checked and appropriate action taken, in accordance with BS 7593 and boiler manufacturers' instructions. *					yes n/a
Comments:					
Signature:					

\*A System inhibitor efficacy test is required on every annual service in accordance with the manufacturers' instructions and BS 7593. It is only acceptable to not have undertaken this if the service engineers attendance visit was in between annual services to attend a non-water facing component.

SERVICE/INTERIM WORK ON BOILER <small>delete as appropriate</small>					Date:
Engineer name:		Company name:			
Telephone N°:		Gas Safe registration N°:			
Max rate	CO	ppm	CO <sub>2</sub>	%	CO/CO <sub>2</sub>
Min rate	CO	ppm	CO <sub>2</sub>	%	CO/CO <sub>2</sub>
Where possible, has a flue integrity check been undertaken in accordance with manufacturers' instructions, and readings are correct?"					yes
Gas rate:	m <sup>3</sup> /h	OR	ft <sup>3</sup> /h		
Were parts fitted? <small>delete as appropriate</small>		Yes	No		
Parts fitted:					
System inhibitor concentration has been checked and appropriate action taken, in accordance with BS 7593 and boiler manufacturers' instructions. *					yes n/a
Comments:					
Signature:					

\*A System inhibitor efficacy test is required on every annual service in accordance with the manufacturers' instructions and BS 7593. It is only acceptable to not have undertaken this if the service engineers attendance visit was in between annual services to attend a non-water facing component.

SERVICE/INTERIM WORK ON BOILER <small>delete as appropriate</small>					Date:
Engineer name:		Company name:			
Telephone N°:		Gas Safe registration N°:			
Max rate	CO	ppm	CO <sub>2</sub>	%	CO/CO <sub>2</sub>
Min rate	CO	ppm	CO <sub>2</sub>	%	CO/CO <sub>2</sub>
Where possible, has a flue integrity check been undertaken in accordance with manufacturers' instructions, and readings are correct?"					yes
Gas rate:	m <sup>3</sup> /h	OR	ft <sup>3</sup> /h		
Were parts fitted? <small>delete as appropriate</small>		Yes	No		
Parts fitted:					
System inhibitor concentration has been checked and appropriate action taken, in accordance with BS 7593 and boiler manufacturers' instructions. *					yes n/a
Comments:					
Signature:					

\*A System inhibitor efficacy test is required on every annual service in accordance with the manufacturers' instructions and BS 7593. It is only acceptable to not have undertaken this if the service engineers attendance visit was in between annual services to attend a non-water facing component.

SERVICE/INTERIM WORK ON BOILER <small>delete as appropriate</small>					Date:
Engineer name:		Company name:			
Telephone N°:		Gas Safe registration N°:			
Max rate	CO	ppm	CO <sub>2</sub>	%	CO/CO <sub>2</sub>
Min rate	CO	ppm	CO <sub>2</sub>	%	CO/CO <sub>2</sub>
Where possible, has a flue integrity check been undertaken in accordance with manufacturers' instructions, and readings are correct?"					yes
Gas rate:	m <sup>3</sup> /h	OR	ft <sup>3</sup> /h		
Were parts fitted? <small>delete as appropriate</small>		Yes	No		
Parts fitted:					
System inhibitor concentration has been checked and appropriate action taken, in accordance with BS 7593 and boiler manufacturers' instructions. *					yes n/a
Comments:					
Signature:					

\*A System inhibitor efficacy test is required on every annual service in accordance with the manufacturers' instructions and BS 7593. It is only acceptable to not have undertaken this if the service engineers attendance visit was in between annual services to attend a non-water facing component.

SERVICE/INTERIM WORK ON BOILER <small>delete as appropriate</small>					Date:
Engineer name:		Company name:			
Telephone N°:		Gas Safe registration N°:			
Max rate	CO	ppm	CO <sub>2</sub>	%	CO/CO <sub>2</sub>
Min rate	CO	ppm	CO <sub>2</sub>	%	CO/CO <sub>2</sub>
Where possible, has a flue integrity check been undertaken in accordance with manufacturers' instructions, and readings are correct?"					yes
Gas rate:	m <sup>3</sup> /h	OR	ft <sup>3</sup> /h		
Were parts fitted? <small>delete as appropriate</small>		Yes	No		
Parts fitted:					
System inhibitor concentration has been checked and appropriate action taken, in accordance with BS 7593 and boiler manufacturers' instructions. *					yes n/a
Comments:					
Signature:					

\*A System inhibitor efficacy test is required on every annual service in accordance with the manufacturers' instructions and BS 7593. It is only acceptable to not have undertaken this if the service engineers attendance visit was in between annual services to attend a non-water facing component.

SERVICE/INTERIM WORK ON BOILER <small>delete as appropriate</small>					Date:
Engineer name:		Company name:			
Telephone N°:		Gas Safe registration N°:			
Max rate	CO	ppm	CO <sub>2</sub>	%	CO/CO <sub>2</sub>
Min rate	CO	ppm	CO <sub>2</sub>	%	CO/CO <sub>2</sub>
Where possible, has a flue integrity check been undertaken in accordance with manufacturers' instructions, and readings are correct?"					yes
Gas rate:	m <sup>3</sup> /h	OR	ft <sup>3</sup> /h		
Were parts fitted? <small>delete as appropriate</small>		Yes	No		
Parts fitted:					
System inhibitor concentration has been checked and appropriate action taken, in accordance with BS 7593 and boiler manufacturers' instructions. *					yes n/a
Comments:					
Signature:					

\*A System inhibitor efficacy test is required on every annual service in accordance with the manufacturers' instructions and BS 7593. It is only acceptable to not have undertaken this if the service engineers attendance visit was in between annual services to attend a non-water facing component.

\* All installations in England and Wales must be notified to Local Authority Building Control (LABC) either directly or through a Competent Persons Scheme. A Building Regulations Compliance Certificate will then be issued to the customer.

© Heating and Hotwater Industry Council (HHIC)



www.centralheating.co.uk







Cod. 20208437 - 07/24 - Ed. 0

**Registered address:**

Vokèra Ltd  
Borderlake House  
Unit 7 Riverside Industrial Estate  
London Colney  
Herts AL2 1HG

**[www.vokera.co.uk](http://www.vokera.co.uk)**  
**[www.vokera.ie](http://www.vokera.ie)**

***Sales, General Enquires***

**T 0330 236 8630**

Vokèra Ireland  
West Court, Callan  
Co Kilkenny  
T 056 7755055

Vokèra Limited reserve the right to change  
specification without prior notice  
Consumers statutory rights are not affected.

Company Reg No: 1047779